

MANHOLE FRAME & LID

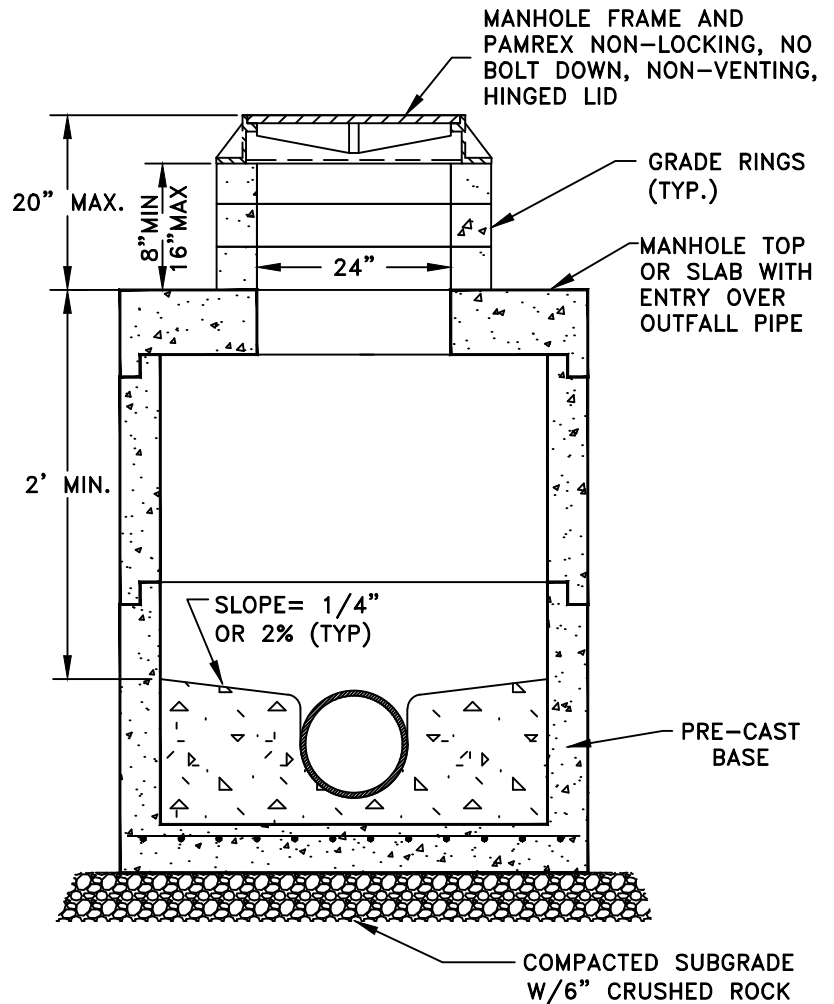

GENERAL NOTES:

1. PRECAST MANHOLES SHALL MEET THE REQUIREMENTS OF ASTM C478. JOINTS SHALL BE RUBBER GASKETED CONFORMING TO ASTM C443 AND IN ADDITION THE JOINTS SHALL BE SEALED WITH BEST SEAL MASTIC.
2. THE LID AND FRAME FOR THE MANHOLE SHALL BE INSTALLED OVER THE OUTFALL CHANNEL AND PIPE.
3. CONNECTION TO EXISTING MANHOLE SHALL BE MADE BY KOR-N-SEAL BOOT OR SAND COLLAR.
4. ALL JOINTS AND LIFTING HOLES SHALL BE GROUTED FROM THE INSIDE AND OUTSIDE.
5. A SEWER GUARD SHALL BE INSTALLED IN ANY MANHOLE SUBJECT TO FLOODING.

CITY OF TUMWATER, WASHINGTON DEPT. OF PUBLIC WORKS				
SHALLOW MANHOLE				
APPROVED				DWG. NO.
CITY ENGINEER				SS-3
DES. TED	DWG. BY TED	CK'D BY TED	DATE FEB. 2024	NOT TO SCALE