

DOUBLE CHECK VALVE ASSEMBLY
 REQUIRED FOR ALL IRRIGATION
 SERVICE LINES. CONTACT PUBLIC
 WORKS DEPT. 754-4150

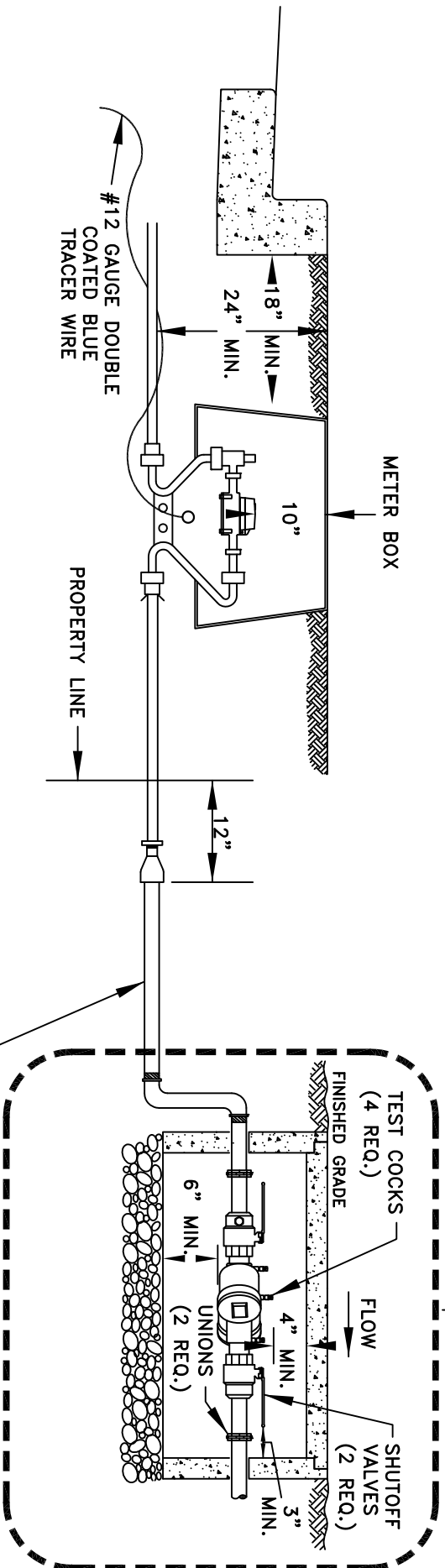

GENERAL NOTES:

1. METER BOXES SHOULD NOT BE DESIGNED IN DRIVEWAYS, DRIVEWAY APPROACHES, SIDEWALKS OR CONFLICTED AREAS. WHEN POSSIBLE CREATE PLANTER AREAS FOR METER BOX INSTALLATION.
2. STAINLESS STEEL INSERTS ARE REQUIRED FOR ALL PACK JOINTS AND GRIP TIGHT ADAPTERS.
3. GALVANIZED PIPES AND FITTINGS BETWEEN WATER METER AND BACKFLOW ASSEMBLY ARE NOT ALLOWED.
4. DOUBLE INSULATED 12 GAUGE BLUE COATED COPPER U.S.E. TONING WIRE SPLICED TO MAINLINE TRACER WIRE ON ALL SERVICE LINES.
5. DOUBLE CHECK VALVE ASSEMBLY SHALL BE A WASHINGTON STATE DEPARTMENT OF HEALTH APPROVED MODEL.
6. DOUBLE CHECK VALVE ASSEMBLY IS TO LAY HORIZONTAL WITH THE GROUND.
7. THE WATER LINE SHALL BE THOROUGHLY FLUSHED PRIOR TO INSTALLING THE BACKFLOW ASSEMBLY.
8. THE DOUBLE CHECK VALVE ASSEMBLY SHALL NOT BE PLACED UNDERGROUND IN AN AREA SUBJECT TO FLOODING.
9. A PLUMBING PERMIT IS REQUIRED.
10. THE BACKFLOW ASSEMBLY SHALL BE TESTED BY A CERTIFIED BACKFLOW ASSEMBLY TESTER AFTER INSTALLATION AND PRIOR TO ACCEPTANCE.
11. TEST RESULTS SHALL BE SENT TO THE CITY OF TUMWATER CROSS CONNECTION SPECIALIST.

GALVANIZED PIPE & FITTINGS
 ARE UNACCEPTABLE

CITY OF TUMWATER, WASHINGTON
 DEPT. OF PUBLIC WORKS

**3/4" & 1" SINGLE METER
 SERVICE W/DCVA**

APPROVED BY:

DWG. NO.

CITY ENGINEER

WA-21.2

DES. PW	DWG. BY PW	CKD BY KMC	DATE JULY 2014	NOT TO SCALE
---------	------------	------------	----------------	--------------