

**City of Tumwater
Drainage Design and Erosion Control
Manual**

**Volume II
Construction Stormwater Pollution Prevention**

January 2018

**Prepared for
City of Tumwater
Public Works Department**

Note:

Some pages in this document have been purposely skipped or blank pages inserted so that this document will copy correctly when duplexed.

Volume II

Construction Stormwater Pollution Prevention

Table of Contents

Chapter 1 – Introduction to Construction Stormwater Pollution Prevention	1-1
1.1 Purpose of this Volume	1-1
1.2 Content and Organization of this Volume.....	1-1
1.3 13 Elements of Construction Stormwater Pollution Prevention	1-2
1.4 Water Quality Standards	1-3
1.4.1 Surface Water Quality Standards.....	1-3
1.4.2 Compliance with Standards	1-4
1.4.3 Enforcement Guidelines	1-4
1.5 Other Applicable Regulations and Permits	1-5
Chapter 2 – Developing and Implementing a Construction Stormwater Pollution Prevention Plan	2-1
2.1 General Guidelines	2-1
2.1.1 What Is a Construction Stormwater Pollution Prevention Plan?.....	2-1
2.1.2 Who Is Responsible for the Construction SWPPP?	2-2
2.1.3 What Is an “Adequate” Plan?	2-2
2.1.4 BMP Standards and Specifications.....	2-3
2.2 Construction SWPPP Submittal Components.....	2-3
2.3 Step-By-Step Procedure	2-8
2.3.1 Step 1 – Data Collection	2-9
2.3.2 Step 2 – Data Analysis.....	2-10
2.3.3 Step 3 – Construction SWPPP Development and Implementation	2-11
Chapter 3 – Standards and Specifications for Best Management Practices.....	3-1
3.1 Source Control BMPs.....	3-1
3.2 Runoff Conveyance and Treatment BMPs.....	3-71
3.3 Protection of LID Facilities During Construction	3-152
3.3.1 Introduction.....	3-152
3.3.2 General Erosion and Sediment Control BMPs Applicable to LID.....	3-152
3.3.3 Additional Construction Techniques for LID BMPs.....	3-153
3.3.4 BMP-Specific Construction Techniques	3-155

**Appendix II-A Recommended Standard Notes for Construction Stormwater
Pollution Prevention Plans..... A-1**

Appendix II-B Background Information on Chemical Treatment..... B-1

Tables

Table 3.1.	Source Control BMPs by SWPPP Element.	3-2
Table 3.2.	Temporary Erosion Control Seed Mix.....	3-22
Table 3.3.	Landscaping Seed Mix.....	3-23
Table 3.4.	Low-Growing Turf Seed Mix.	3-23
Table 3.5.	Bioswale Seed Mix.	3-23
Table 3.6.	Low-Growing, Wet Area Seed Mix.*	3-24
Table 3.7.	Meadow Seed Mix.	3-24
Table 3.8.	Mulch Standards and Guidelines.	3-27
Table 3.9.	PAM and Water Application Rates.....	3-44
Table 3.10.	Runoff Conveyance and Treatment BMPs by SWPPP Element.	3-72
Table 3.11.	Storm Drain Inlet Protection.	3-103
Table 3.12.	Geotextile Minimum Standards.	3-109
Table 3.13.	Vegetated Strips.	3-114
Table 3.14.	Flowpath Guidelines for Vegetative Filtration.	3-121
Table 3.15.	General Erosion and Sediment Control BMPs Applicable to LID.	3-153
Table 3.16.	Construction Site Planning and Sequencing Techniques to Protect LID BMPs.....	3-154
Table 3.17.	Activities During Construction to Protect LID BMPs.....	3-155
Table 3.18.	Techniques to Protect Infiltration and Dispersion Facility During Construction.....	3-156

Figures

Figure 3.1	Stabilized Construction Entrance.....	3-11
Figure 3.2.	Wheel Wash.	3-15
Figure 3.3.	Channel Installation.	3-32
Figure 3.4	Slope Installation.	3-33
Figure 3.5.	Surface Roughening by Tracking and Contour Furrows.	3-48
Figure 3.6.	Gradient Terraces.....	3-50
Figure 3.7.	Prefabricated Concrete Washout Container with Ramp.	3-64
Figure 3.8.	Concrete Washout Area A.	3-65
Figure 3.9.	Concrete Washout Area B.	3-66
Figure 3.10.	Typical Grass-Lined Channels.....	3-76
Figure 3.11.	Temporary Channel Liners.	3-78
Figure 3.12.	Water Bar.	3-83
Figure 3.13.	Pipe Slope Drain.	3-86
Figure 3.14.	Cross-Section of Level Spreader.	3-93
Figure 3.15.	Detail of Level Spreader.	3-94
Figure 3.17.	Check Dams.	3-97
Figure 3.17.	Rock Sock Drop Inlet Protection.	3-104
Figure 3.18.	Curb and Gutter Barrier.	3-106
Figure 3.19.	Silt Fence.	3-108

Figure 3.20. Silt Fence Installation by Slicing Method..... 3-112
Figure 3.21. Straw Wattles..... 3-117
Figure 3.22. Manifold and Branches in a Wooded Vegetative Filtration Area..... 3-122
Figure 3.23. Cross-Section of Sediment Trap..... 3-125
Figure 3.24. Sediment Trap Outlet..... 3-125
Figure 3.25. Sediment Pond Plan View..... 3-128
Figure 3.26. Sediment Pond Cross-Section..... 3-128
Figure 3.27. Sediment Pond Riser Detail..... 3-129
Figure 3.28. Riser Inflow Curves..... 3-131

Chapter 1 – Introduction to Construction Stormwater Pollution Prevention

1.1 Purpose of this Volume

This volume (Volume II) of the *Drainage Design and Erosion Control Manual* focuses on managing stormwater impacts associated with construction activities. Best management practices (BMPs) that are properly planned, installed, and maintained can minimize stormwater impacts, such as heavy stormwater flows, soil erosion, water-borne sediment from exposed soils, and degradation of water quality, from on-site pollutant sources. This chapter addresses the planning, design, and implementation of BMPs before and during construction projects.

The construction phase of a project is usually a temporary condition, ultimately giving way to permanent improvements and facilities. However, construction work may take place over an extended period of time. Ensure that all of your management practices and control facilities are of sufficient size, strength, and durability to outlast the longest possible construction schedule and the worst anticipated rainfall conditions.

Linear projects, such as roadway construction and utility installations, may present a unique set of stormwater protection challenges. You can adapt or modify many of the BMPs discussed in this volume to provide the controls needed to address these projects. It may be advantageous to phase portions of long, linear projects and apply all necessary controls to individual phases.

This volume details BMPs for controlling or maintaining stormwater runoff quality from a developed or artificially altered site during construction. The project applicant or his/her designated project engineer shall prepare one of the three site development and stormwater submittals; a Stormwater Pollution Prevention Plan (SWPPP) Short Form (See Volume I, Appendix I-B), a Drainage Control Plan, or an Abbreviated Plan. For most projects, a component of the submittal is the Construction SWPPP.

The Construction SWPPP serves as a tool for the site operator to manage the site and to avoid immediate and long-term environmental loss. Additional information on erosion and sedimentation processes as well as factors influencing erosion potential may be found in the 2014 Ecology Stormwater Management Manual for Western Washington.

1.2 Content and Organization of this Volume

Volume II is organized into three chapters that address key considerations and mechanics of construction stormwater BMPs.

Chapter 1 includes the introduction and purpose of the chapter. The section briefly lists 13 elements of pollution prevention to be considered for all projects. Additional local, state, and federal requirements that may apply to construction sites and their stormwater

discharges are noted. This includes Ecology's National Pollutant Discharge Elimination System (NPDES) Discharge Permit and Washington's water quality standards pertaining to construction stormwater, and explains how they apply to field situations

Chapter 2 provides additional information on requirements for construction erosion control, including seasonal limitations and required components of the Construction SWPPP.

Chapter 3 contains BMPs for construction stormwater control and site management. The first section (Section 3.1) of Chapter 3 contains BMPs for source control. The second section (Section 3.2) addresses runoff, conveyance, and treatment BMPs. The third section (Section 3.3) presents practices specifically to protect low impact development (LID) BMPs during construction. Use various combinations of these BMPs in the Construction SWPPP to satisfy each of the 13 elements applicable to the project. Design and facility sizing information is included within the applicable BMP sections. The project applicant should refer to this chapter to determine which BMPs to include in the Construction SWPPP, and to design and document application of these BMPs to the project construction site.

1.3 13 Elements of Construction Stormwater Pollution Prevention

The **13 Elements** listed below must be considered in the development of the Construction SWPPP. If an element is considered unnecessary, the Construction SWPPP must provide the justification.

These elements cover the general water quality protection strategies of limiting site impacts, preventing erosion and sedimentation, and managing activities and sources.

The 13 elements are:

1. Preserve vegetation/mark clearing limits
2. Establish construction access
3. Control flow rates
4. Install sediment controls
5. Stabilize soils
6. Protect slopes
7. Protect drain inlets
8. Stabilize channels and outlets
9. Control pollutants

10. Control dewatering
11. Maintain BMPs
12. Manage the project
13. Protect Low Impact Development BMPs

For a complete description of each element and associated BMPs, see Chapter 2.

1.4 Water Quality Standards

1.4.1 Surface Water Quality Standards

“Numerical” water quality criteria are numerical values set forth in the State of Washington’s Water Quality Standards for Surface Waters (WAC Chapter 173-201A). They specify the levels of pollutants allowed in receiving waters to protect aquatic life.

U.S. Environmental Protection Agency (U.S. EPA) has promulgated 91 numeric water quality criteria to protect human health that apply to Washington State. These criteria are designed to protect humans from cancer and other diseases, and are primarily applicable to fish and shellfish consumption and drinking water obtained from surface waters.

In addition to numerical criteria, “narrative” water quality criteria (e.g., WAC 173-201A-200, -240, and -250) limit concentrations of toxic, radioactive, or otherwise harmful material below concentrations that have the potential to adversely affect characteristic water uses, cause acute or chronic toxicity to biota, impair aesthetic values, or adversely affect human health. Narrative criteria protect the specific beneficial uses of fresh (WAC 173-201A-600 and -602) and marine (WAC 173-201A-610 and -612) waters in the State of Washington.

Pollutants that might be expected in the discharge from construction sites are turbidity, pH, and petroleum products. The numeric surface water quality standards for turbidity and pH for fresh and marine waters designated for various aquatic life uses are specified in WAC 173-201A-200 and -210.

Although there is no specific surface or groundwater quality standard for petroleum products, the narrative surface water quality criteria prohibit any visible sheen in a discharge to surface water.

The groundwater quality criteria require protection from contamination in order to support the beneficial uses of the groundwater, such as for drinking water. Therefore, the primary water quality consideration for stormwater discharges to groundwater from construction sites is the control of contaminants other than sediment. However, sediment control is necessary to protect permanent infiltration facilities from clogging during the construction phase.

1.4.2 Compliance with Standards

Stormwater discharges from construction sites must not cause or contribute to violations of Washington State's surface water quality standards (Chapter 173-201A WAC), sediment management standards (Chapter 173-204 WAC), groundwater quality standards (Chapter 173-200 WAC), and human health based criteria in the National Toxics Rule (40 CFR Part 131.36).

Before the site can discharge stormwater and non-stormwater to waters of the State, the project applicant must apply all known, available, and reasonable methods of prevention, control, and treatment (AKART, as defined in WAC 173-218-030). This includes preparing and implementing a Construction SWPPP, with all appropriate BMPs installed and maintained in accordance with the Construction SWPPP and the terms and conditions of the Construction Stormwater General Permit (CSWGP) (if applicable; see also Volume I, Section 1.5 of this manual).

In accordance with Chapter 90.48 RCW (ESSB 6415), compliance with water quality standards is presumed unless discharge monitoring data or other site specific information demonstrates otherwise, when the project applicant fully:

- Complies with applicable permit conditions for planning, sampling, monitoring, reporting, and recordkeeping; and
- Implements the BMPs contained in this manual, including the proper selection, implementation, and maintenance of all applicable and appropriate BMPs for on-site pollution control.

Proper implementation and maintenance of appropriate BMPs is critical to adequately control any adverse water quality impacts from construction activity.

Because Ecology has determined that a local manual may be used where the local requirements for construction sites are at least as stringent as Ecology's, applicants should be able to prepare one Construction SWPPP under this manual to satisfy both the Ecology permit and Tumwater permits. However, for sites also subject to Ecology's NPDES CSWGP requirements, applicants are responsible for confirming that no additional requirements apply to comply with Ecology's regulations.

1.4.3 Enforcement Guidelines

For projects that are subject to Ecology's NPDES CSWGP or Industrial Stormwater General Permit (ISWGP) requirements, water quality monitoring shall be conducted in accordance with the applicable permit. In cases where water quality standards conflict, the more stringent water quality standard shall apply. For projects that are not subject to Ecology's NPDES CSWGP or ISWGP requirements, water quality compliance monitoring in this section shall apply. In such cases, the City of Tumwater will perform water quality compliance monitoring, as needed, to confirm that discharge and water quality standards are being met. The purpose of compliance monitoring is to ensure protection of water resources and stormwater infrastructure, not to punish violators.

Therefore, the initial and primary enforcement tool shall be a correction notice, compliance order, or similar action. If the situation is not corrected within the timelines set in the correction notice, all construction work will be halted (with a stop work order if necessary) until appropriate erosion prevention and sediment control BMPs are in place, and runoff meets applicable discharge and water quality standards.

If a timely and adequate response does not occur, or in cases of severe repeated violations, the city shall, at its discretion, issue infraction notices or citations carrying monetary penalties (per TMC 13.12.020).

The following surface water standard applies to all construction sites:

- For storms up to the water quality design event, turbidity downstream of a construction site may not increase more than 5 nephelometric turbidity units (NTU), if upstream turbidity is 50 NTU less, and may not increase more than 10 percent, if upstream turbidity is over 50 NTU. To the extent practicable, samples shall be taken far enough downstream so that the construction site discharge has been well-mixed with surface water.
- Whenever inspection or monitoring reveals that the BMPs identified in the Construction SWPPP are inadequate, due to actual discharge of or potential to discharge a significant amount of any pollutant, appropriate BMPs or design changes shall be implemented as soon as possible.

1.5 Other Applicable Regulations and Permits

In addition to Tumwater regulations, other regulations and permits may require the implementation of BMPs to control pollutants in construction site stormwater runoff. These include but may not be limited to the following (principal permitting agency in brackets):

- NPDES Construction General Permit – (Ecology)
<www.ecy.wa.gov/programs/wq/stormwater/construction>
- Total Maximum Daily Load (TMDLs) or water cleanup plans – (Ecology)
- Endangered Species Act (ESA) – (National Oceanic and Atmospheric Administration [NOAA] Fisheries Service and/or U.S. Fish and Wildlife Service [USFWS])
- Hydraulic Project Approval (HPA) permits (Washington Department of Fish and Wildlife [WDFW])
- General provisions from the Washington State Department of Transportation (WSDOT)
- Remediation agreements for contaminated sites (such as Model Toxics Control Act [MTCA] or Voluntary Cleanup Program sites)

See Volume I, Section 1.5 for further information.

Chapter 2 – Developing and Implementing a Construction Stormwater Pollution Prevention Plan

This chapter provides an overview of the important components of, and the process for, developing and implementing a Construction SWPPP.

Section 2.1 contains general guidelines with which site planners should become familiar. It describes criteria for plan format and content and ideas for improved plan effectiveness.

Section 2.2 discusses the two main components of a Construction SWPPP, the narrative and the drawings.

Section 2.3 outlines and describes the step-by-step procedure for developing a Construction SWPPP from data collection to finished product. Step 3 in Section 2.2.3 provides a description of each of the Construction SWPPP elements. This procedure is written in general terms to be applicable to all types of projects.

Design standards and specifications for BMPs referred to in this chapter are found in Chapter 3.

The Construction SWPPP is a subset of the submittal requirements outlined in Volume I.

2.1 General Guidelines

2.1.1 What Is a Construction Stormwater Pollution Prevention Plan?

The Construction SWPPP is a written plan to implement measures to identify, prevent, and control the contamination of point source discharge of stormwater. The Construction SWPPP explains and illustrates the measures, usually in the form of BMPs, to take on a construction site to control potential pollution problems. The Construction SWPPP must include a narrative as well as drawings and details (see Volume I, Chapter 3, Table 3.1, for threshold limits for various plan submittals). Projects that add or replace less than 2,000 square feet of hard surface or disturb less than 7,000 square feet of land (including many single-family building sites) are not required to prepare a full Construction SWPPP, but must still consider all 13 elements of Construction Stormwater Pollution Prevention and develop controls for all elements that pertain to the project site. These smaller projects shall use the Construction SWPPP Short Form provided in Appendix I-B to document compliance with the 13 elements and Minimum Requirement #2.

As site work progresses, the plan must be modified to reflect changing site conditions, subject to the rules for plan modification by the CSWGP and/or the city. See also Construction SWPPP Element #12 in Section 2.3.3, Step 3.

2.1.2 Who Is Responsible for the Construction SWPPP?

The owner or lessee of the land being developed has the responsibility for Construction SWPPP preparation and submission to the city. The owner or lessee may designate someone (i.e., an engineer, architect, contractor, etc.) to prepare the Construction SWPPP, but he/she retains the ultimate responsibility for environmental protection at the site.

The Construction SWPPP must be located on the construction site or within reasonable access to the site for construction and inspection personnel, although a copy of the drawings must be kept on the construction site at all times.

2.1.3 What Is an “Adequate” Plan?

The Construction SWPPP must contain sufficient information to satisfy the city that the problems of construction pollution have been adequately addressed for the proposed project.

An adequate Construction SWPPP includes a narrative and drawings. The narrative is a written statement to explain and justify the pollution prevention decisions made for a particular project. The narrative contains concise, site specific, information about existing conditions, construction schedules, and other pertinent items that are not contained on the drawings. The drawings show, on a site map, the specific BMPs that shall be installed. Provide text notes on the drawings to describe the performance standards the BMPs must achieve, and actions to take if the performance goals are not achieved.

Reports summarizing the scope of inspections, the personnel conducting the inspections, the date(s) of the inspections, major observations relating to implementing the Construction SWPPP, and actions taken as a result of these inspections must be prepared and retained as part of the Construction SWPPP.

On construction sites that discharge to surface water, the primary concern in the preparation of the Construction SWPPP is compliance with Washington State Water Quality Standards.

On construction sites that infiltrate all stormwater runoff, the primary concern in the preparation of the Construction SWPPP is the protection of the infiltration facilities from fine sediments during the construction phase and protection of groundwater from other pollutants. Several of the other elements are very important at these sites as well, such as marking the clearing limits, establishing the construction access, and managing the project.

Whether the stormwater discharges to surface water or completely infiltrates, each of the 13 elements (Section 2.3.3) must be included in the Construction SWPPP, unless an element is determined to not be applicable to the project and the exemption is justified in the narrative.

The step-by-step procedure outlined in Section 2.3 is recommended for the development of Construction SWPPPs. For sites that do not trigger a full Construction SWPPP (see Volume I), a SWPPP Short Form is provided in Volume I, Appendix I-B.

2.1.4 BMP Standards and Specifications

BMPs refer to schedules of activities; prohibitions of practices; maintenance procedures; and other physical, structural, and/or managerial practices to prevent or reduce the pollution of waters of the State. BMPs include treatment systems, operating procedures, and practices to control:

- Stormwater associated with construction activity
- Groundwater associated with construction activity
- Spillage or leaks
- Sludge or waste disposal
- Drainage from raw material storage

Chapter 3 contains standards and specifications for the BMPs commonly used in Construction SWPPPs to address the 13 elements, as well as additional techniques specific to protection of LID BMPs during construction. Construction SWPPP BMPs can be used singularly or in combination. If a Construction SWPPP makes use of a BMP, the narrative and drawings must clearly reference the specific BMP title and number.

The standards and specifications in Chapter 3 of this volume are not intended to limit any innovative or creative effort to effectively control erosion and sedimentation. Construction SWPPPs can contain experimental BMPs or make minor modifications to standard BMPs. However, both the city and Ecology must approve such practices before use. All experimental BMPs and modified BMPs must achieve the same or better performance than the BMPs listed in Chapter 3.

2.2 Construction SWPPP Submittal Components

The Construction SWPPP shall consist of two parts: a narrative and the drawings. The following sections describe the contents of each.

Narrative

Cover Sheet: The Construction SWPPP narrative report shall have a cover sheet with the project name; applicant's name, address, telephone number, and email address; project engineer's name, address, telephone number, and email address; date of submittal; contact's name, address telephone number, and email address; and the name, address telephone number, and email address of contractor and Certified Erosion and Sediment Control Lead (CESCL), if known.

Project Engineer’s Certification: For some Abbreviated Plan submittals, the Construction SWPPP need not be developed by a professional engineer. However, for more complex projects submitting an Abbreviated Plan with engineering elements (e.g., to support Minimum Requirement #5, as outlined in Volume I) or a Drainage Control Plan, as per the rest of the submittal the Construction SWPPP must be developed by a professional engineer licensed to practice in the State of Washington. For projects where a PE is required, the Construction SWPPP report shall contain a page with the project engineer’s seal with the following statement:

“I hereby state that this Construction Stormwater Pollution Prevention Plan for _____ (name of project) has been prepared by me or under my supervision and meets the standard of care and expertise which is usual and customary in this community for professional engineers. I understand that the City of Tumwater does not and will not assume liability for the sufficiency, suitability, or performance of Construction SWPPP BMPs prepared by me.”

Table of Contents: Show the page number for each section of the report. Show page numbers of appendices.

Certified Erosion Control Lead: Site inspections shall be conducted by a person who is knowledgeable in the principles and practices of erosion and sediment control. For project sites that require a Construction SWPPP, a CESCL shall be identified in the Construction SWPPP and shall be on site or on call at all times.

The author of the Construction SWPPP should evaluate the following subject areas for inclusion in the Construction SWPPP narrative. The subject areas below are not a required outline for the Construction SWPPP narrative.

- **General Information on the Existing Site and Project:**
 - *Project description* – Describe the nature and purpose of the construction project. Include the total size of the area, any increase in existing impervious area; the total area expected to be disturbed by clearing, grading, excavation or other construction activities, including off-site borrow and fill areas; and the volumes of grading cut and fill that are proposed.
 - *Existing site conditions* – Describe the existing topography, vegetation, and drainage. Include a description of any structures or development on the parcel including the area of existing hard surfaces.
 - *Adjacent areas* – Describe adjacent areas, including streams, lakes, wetlands, residential areas, and roads that might be affected by the construction project. Describe how upstream drainage areas may affect the site. Provide a description of the downstream drainage leading from the site to the receiving water body.

- *Critical areas* – Describe areas on or adjacent to the site that are classified as critical areas. Critical areas that receive runoff from the site shall be described up to 0.25 mile away. Describe special requirements and provisions for working near or within these areas.
- *Soil* – Describe the soil on the site, giving such information as soil names, mapping unit, soil classification, erodibility, ability to settle, permeability, depth, texture, and soil structure.
- *Potential erosion problem areas* – Describe areas on the site that have potential erosion problems.
- **Thirteen Elements:** Describe how the Construction SWPPP addresses each of the 13 required elements. Include the type and location of BMPs used to satisfy the required element. Often using a combination of BMPs is the best way to satisfy required elements. If an element is not applicable to a project, provide a written justification for why it is not necessary.
- **Construction Phasing:** Describe the intended sequence and timing of construction activities, as well as any proposed construction phasing.
- **Construction Schedule:** Describe the construction schedule. If the schedule extends into the wet season, describe what activities will continue during the wet season and how the transport of sediment from the construction site to receiving waters will be prevented. Describe the intended sequence and timing of construction activities and any proposed construction phasing (including construction restraints for environmentally sensitive areas). Refer to Section 2.3.3, Element #12, for additional seasonal work considerations that should be reflected in the Construction SWPPP.
- **Financial/Ownership Responsibilities:** Describe ownership and obligations for the project. Include bond forms and other evidence of financial responsibility for environmental liabilities associated with construction.
- **Engineering Calculations:** Attach any calculations made for the design of such items as sediment ponds, diversions, and waterways, as well as calculations for runoff and stormwater detention design (if applicable).
- **Inspection Checklists and Monitoring Forms:** Attach a blank for to be completed when conducting inspections and monitoring stormwater quality. See BMP C160 for inspection documentation requirements.

Drawings

It is the responsibility of the project engineer to ensure that engineering drawings supporting the Construction SWPPP shall be sufficiently clear to construct the project in proper sequence, using specified methods and materials, with sufficient dimensions to

fulfill the intent of drainage laws and ordinances and these design guidelines. The Construction SWPPP drawings shall include the following items:

- **Vicinity Map:** Provide a map with enough detail to identify the location of the construction site, show adjacent roads, parcels and receiving waters.
- **Site Map:** Provide a site map(s) showing the following features. The site map requirements may be met using multiple plan sheets for ease of legibility.
 - A legal description of the property boundaries or an illustration of property lines (including distances) on the drawings.
 - The direction of north in relation to the site.
 - Existing structures and roads.
 - The boundaries and identification of different soil types.
 - Areas of potential erosion problems.
 - Any on-site and adjacent surface waters, critical areas, their buffers, flood plain boundaries, and Shoreline Management boundaries.
 - Existing contours and drainage basins and the direction of flow for the different drainage areas. Contour intervals on the site plan shall be at a minimum as follows:

Slope (percent)	Contour Interval (feet)
0 to 15	2
16 to 40	5
>40	10

- Topography must be field verified for drainage easements and conveyance systems. Contours shall extend a minimum of 25 feet beyond property lines and shall extend sufficiently to depict existing conditions. If survey is restricted to the project site due to lack of legal access, contours shall be provided by other means; e.g., Thurston County Geodata, LiDAR data.
- Final and interim grade contours as appropriate, drainage basins, and the direction of stormwater flow during and upon completion of construction.
- Areas of soil disturbance, including all areas affected by clearing, grading, and excavation.
- Locations where stormwater will discharge to surface waters and the city storm drain system during and upon completion of construction, and locations where the site receives off-site flow.

- Existing unique or valuable vegetation and the vegetation that is to be preserved.
- Cut and fill slopes indicating top and bottom of slope catch lines.
- Total cut and fill quantities and the method of disposal for excess material.
- Stockpile; waste storage; and vehicle storage, maintenance, and washdown areas.
- Locations of all joint utility trenches and details of associated erosion and sediment transport control features.
- **Conveyance Systems:** Show on the site map the following temporary and permanent conveyance features:
 - Locations for temporary and permanent swales, interceptor trenches, ditches, or pipes associated with erosion and sediment control and stormwater management
 - Temporary and permanent pipe inverts and minimum slopes and cover
 - Grades, dimensions, and direction of flow in all ditches and swales, culverts, and pipes
 - Details for bypassing off-site runoff around disturbed areas
 - Locations and outlets of any dewatering systems.
- **Location of Treatment and Detention BMPs:** Show on the site map the locations of temporary and permanent stormwater treatment and/or flow control BMPs.
- **Erosion and Sediment Control BMPs:** Show on the site map all major structural and nonstructural BMPs, including:
 - The location of sediment pond(s), pipes, and structures
 - Dimension pond berm widths and inside and outside pond slopes
 - The trap/pond storage required and the depth, length, and width dimensions
 - Typical section views through pond and outlet structure
 - Typical details of gravel cone and standpipe, and/or other filtering devices
 - Stabilization technique details for inlets and outlets
 - Location and type of storm drain inlet protection

- Control/restrictor device location and details
- Stabilization and cover practices for berms, slopes, and disturbed areas
- Rock specifications and detail for rock check dam, if used
- Spacing for rock check dams as required
- Front and side sections of typical rock check dams
- The location, detail, and specification for silt fence
- The construction entrance location and a detail.
- **Detailed Drawings:** Any structural practices used that are not referenced in this manual or other local manuals shall be explained and illustrated with detailed drawings.
- **Other Pollutant BMPs:** Indicate on the site map the location of BMPs to be used for the control of pollutants other than sediment. This can include designated concrete washout area, refueling sites or other BMPs for pollutant control.
- **Monitoring Locations:** Indicate on the site map any required water quality sampling locations. Sampling stations shall be located in accordance with applicable permit requirements.
- **Standard Notes:** Notes addressing construction phasing and scheduling shall be included on the drawings. Standard notes can be found in Appendix II-A.

2.3 Step-By-Step Procedure

There are three basic steps in producing a Construction SWPPP:

- **Step 1:** Data Collection
- **Step 2:** Data Analysis
- **Step 3:** Construction SWPPP Development and Implementation

Steps 1 through 3 (described below) are intended for projects that are adding or replacing 2,000 square feet or more of hard surface, or clearing 7,000 square feet or more. Smaller projects (such as most individual single-family home sites) must use the SWPPP Short Form provided in Volume I, Appendix I-B, rather than a complete Construction SWPPP. See Volume I for further details on project submittal requirements.

2.3.1 Step 1 – Data Collection

Evaluate existing site conditions and gather information that will help develop the most effective Construction SWPPP.

- **Topography:** Prepare a topographic drawing of the site to show the existing contour elevations at intervals of 1 to 5 feet, depending upon the slope of the terrain.
- **Drainage:** Locate and clearly mark existing drainage swales and patterns on the drawing, including existing storm drain pipe systems.
- **Soils:** Identify and label soil type(s) and erodibility (slight, moderate, severe, very severe, or an index value, such as the K factor, which can be obtained from the Natural Resources Conservation Service (NRCS) Web Soil Survey) on the drawing or in the narrative.

Characterize soils for permeability, water holding capacity, percent organic matter, and effective depth. Express these qualities in averaged or nominal terms for the subject site or project. This information is typically available in literature published by qualified soil professionals or engineers, such as the U.S. Department of Agriculture (USDA) Soil Conservation Service (now the NRCS) Soil Survey of Thurston County or the NRCS Web Soil Survey web site at <websoilsurvey.nrcs.usda.gov/app/HomePage.htm>. For projects that trigger Minimum Requirement #5, #6, or #7 (Volume I), a more detailed soils investigation is required and must be used for the SWPPP soils characterization.

- **Ground Cover:** Label existing vegetation on the drawing. Show features such as tree clusters, grassy areas, and unique or sensitive vegetation. Unique vegetation may include existing trees above a given diameter. Requirements regarding tree preservation should be investigated (refer to TMC Chapter 16.08). In addition, existing denuded or exposed soil areas should be indicated.
- **Critical Areas:** Delineate critical areas adjacent to or within the site on the drawing. Show features such as steep slopes, streams, floodplains, lakes, wetlands, sole source aquifers, and geologic hazard areas. Delineate setbacks and buffer limits for these features on the drawings. On the drawings, show other related jurisdictional boundaries such as Shorelines Management and the Federal Emergency Management Agency (FEMA) Special Flood Hazard Areas. Some critical areas may require specialist and or a separate permit to develop and locate per TMC Title 16 (these may include aquifer recharge areas, geologic hazard areas, floodplains, streams, and wetlands).
- **Adjacent Areas:** Identify existing buildings, roads, and facilities adjacent to or within the project site on the drawings. Identify existing and proposed utility locations, construction clearing limits and Construction SWPPP BMPs on the drawings.

- **Existing Encumbrances:** Identify wells, existing and abandoned septic drainfields, utilities, easements, setbacks, and site constraints.
- **Precipitation Records:** Refer to Volume III, Chapter 2, to determine the required rainfall records and the method of analysis for design of BMPs.

2.3.2 Step 2 – Data Analysis

Consider the data collected in Step 1 to visualize potential problems and limitations of the site. Determine those areas that have critical erosion hazards. The following are some important factors to consider in data analysis:

- **Ground Cover:** Ground cover is the most important factor in terms of preventing erosion. Existing vegetation that can be saved will prevent erosion better than constructed BMPs. Trees and other vegetation protect the soil structure. If the existing vegetation cannot be saved, consider such practices as phasing construction, temporary seeding, and mulching. Phasing construction involves stabilizing one part of the site before disturbing another. In this way, the entire site is not disturbed at once.
- **Topography:** The primary topographic considerations are slope steepness and length. Steeper and longer slopes have greater erosion potential than do flat and short slopes. A qualified engineer, soil professional, or certified erosion control specialist should determine erosion potential.
- **Drainage:** Convey runoff through the use of natural drainage patterns that consist of overland flow, swales and depressions to avoid constructing an artificial drainage system. Properly stabilize man-made ditches and waterways so they do not create erosion problems. Take care to ensure that increased runoff from the site will not erode or flood the existing natural drainage system. Consider possible sites for temporary stormwater retention and detention.

Direct construction away from areas of saturated soil where groundwater may be encountered and away from critical areas where drainage will concentrate. Preserve natural drainage patterns on the site.

- **Soils:** Evaluate soil properties such as surface and subsurface runoff characteristics, depth to impermeable layer, depth to seasonal groundwater table, permeability, shrink-swell potential, texture, ability to settle, and erodibility. Develop the Construction SWPPP based on known soil characteristics. Protect infiltration sites from clay and silt, which will reduce infiltration capacities and from compaction by heavy traffic.
- **Critical Areas:** Critical areas, per TMC Title 16, may include but are not limited to wetlands, areas with a critical recharging effect on aquifers used for potable water wellhead protection areas, fish and wildlife habitat conservation areas, frequently flooded areas, and geologically hazardous areas. Delineate critical

areas and their buffers on the drawings and clearly flag critical areas in the field. For example, fencing may be more useful than flagging to ensure that equipment operators stay out of critical areas. Only unavoidable work shall take place within critical areas and their buffers. Such unavoidable work will require special BMPs, permit restrictions, and mitigation plans—documented in the Construction SWPPP. Temporary stormwater management facilities within wellhead protection areas shall meet requirements within all volumes of this manual related to wellhead protection areas.

- **Adjacent Areas:** An analysis of adjacent properties should focus on areas upslope and downslope from the construction project. Water bodies that will receive direct runoff from the site are a major concern. Evaluate the types, values, and sensitivities of and risks to downstream resources, such as private property, stormwater facilities, public infrastructure, or aquatic systems. Select Construction SWPPP BMPs accordingly.
- **Precipitation Records:** Refer to Volume III, Chapter 2, to determine the required rainfall records and the method of analysis for design of BMPs.
- **Timing of the Project:** Consider the timing and duration of the project when selecting BMPs. Projects that will proceed during the wet season and projects that will last through several seasons must take all necessary precautions to remain in compliance with the water quality standards

2.3.3 Step 3 – Construction SWPPP Development and Implementation

After collecting and analyzing the data to determine the site limitations, a Construction SWPPP can then be developed. **The 13 elements below must be considered and included in the Construction SWPPP. If site conditions render an element unnecessary, the exemption for that element must be clearly justified in the narrative of the Construction SWPPP.**

The Construction SWPPP shall be implemented starting prior to any land disturbance and continue until final stabilization.

Ecology provides a template for preparing the Construction SWPPP at: www.ecy.wa.gov/programs/wq/stormwater/construction. Tables 3.1 and 3.2 in Chapter 3 present recommended BMPs for each of the required elements.

Element #1: Preserve Vegetation/Mark Clearing Limits

- Before beginning land disturbing activities, including clearing and grading, clearly mark all clearing limits, sensitive areas and their buffers, and trees that are to be preserved within the construction area.
- Retain the duff layer, native top soil, and natural vegetation in an undisturbed state to the maximum degree practical.
- Plastic, metal, or fabric fence shall be used to mark the clearing limits. [Note the difference between the practical use and proper installation of silt fencing, and the proper use of high visibility fencing.]
- If it is not practical to retain the duff layer in place, then stockpile it on site, cover it to prevent erosion, and replace it immediately when you finish disturbing the site. See the post construction soil quality and depth BMP in Volume V, Chapter 6 for more information.
- Suggested BMPs:
 - BMP C101: Preserving Natural Vegetation
 - BMP C102: Buffer Zones
 - BMP C103: High Visibility Fence
 - BMP C233: Silt Fence

Element #2: Establish Construction Access

- Limit construction vehicle access and exit to one route, if possible. Minimize construction site access points along linear projects, such as roadways.
- Stabilize access points with a pad of quarry spalls, crushed rock, or other equivalent BMPs, to minimize tracking sediment onto all roads and accesses.
- Locate wheel wash or tire baths on site, if the stabilized construction entrance is not effective in preventing tracking sediment onto roads/accesses.
- If sediment is tracked off site, clean the affected roadway/access thoroughly at the end of each day, or more frequently as necessary (for example, during wet weather). Remove sediment from roads by shoveling, sweeping, or pick up and transport the sediment to a controlled sediment disposal area.
- Conduct street washing only after sediment is removed in accordance with the above bullet.

- Control street wash wastewater by pumping back on site to an approved infiltration facility, or otherwise preventing it from discharging into systems tributary to the city municipal separated storm sewer system (MS4), wetlands, or waters of the State. Options include discharge to the sanitary sewer, or discharge to an approved treatment system. For discharges to a permanent infiltration facility, sediment must be removed from the facility after final stabilization. For discharges to the sanitary sewer, permits must be obtained from the LOTT Clean Water Alliance, Industrial Pretreatment Program at 360-528-5708.
- Suggested BMPs:
 - BMP C105: Stabilized Construction Entrance
 - BMP C106: Wheel Wash
 - BMP C107: Construction Road/Parking Area Stabilization.

Element #3: Control Flow Rates

- Protect properties and waterways downstream of development sites from erosion and the associated discharge of turbid waters due to increases in the velocity and peak volumetric flow rate of stormwater runoff from the project site.
- Where necessary to comply with the bullet above, construct stormwater retention or detention facilities as one of the first steps in grading. Ensure that detention facilities function properly before constructing site improvements (e.g., impervious surfaces).
- Sites that must implement flow control for the developed site condition must also control stormwater release rates during construction. Construction site stormwater discharges shall not exceed the discharge durations of the predeveloped condition for the range of predeveloped discharge rates from half of the 2-year flow through the 10-year flow as predicted by an approved continuous runoff model. The predeveloped condition to be matched shall be the land cover condition immediately prior to the development project. This restriction on release rates can affect the size of the storage pond and treatment cells. The city may require designs that provide additional or different stormwater flow control if necessary to address local conditions or to protect properties and waterways downstream from high flow impacts.
- If permanent infiltration ponds are used for flow control during construction, protect these facilities from siltation during the construction phase and remove all accumulated sediment and confirm infiltration is restored after final stabilization.
- Conduct downstream analysis if changes in off-site flows could impair or alter conveyance systems, stream banks, bed sediment, or aquatic habitat. See Volume I, Chapter 2 for potential off-site analysis requirements and guidelines.

- Even gently sloped areas need flow controls such as straw wattles or other energy dissipation/filtration structures. Place dissipation facilities closer together on steeper slopes. These methods prevent water from building higher velocities as it flows downstream within the construction site.
- Outlet structures designed for permanent detention ponds are not appropriate for use during construction without modification. If used during construction, install an outlet structure that will allow for long-term storage of runoff and enable sediment to settle. Verify that the pond is sized appropriately for this purpose. Restore ponds to their original design dimensions, remove sediment, and install a final outlet structure at completion of the project.
- Suggested BMPs:
 - BMP C203: Water Bars
 - BMP C207: Check Dams
 - BMP C209: Outlet Protection
 - BMP C235: Wattles
 - BMP C240: Sediment Trap
 - BMP C241: Temporary Sediment Pond

Refer also to Volume V, Flow Control Design.

Element #4: Install Sediment Controls

- Design, install, and maintain effective erosion controls and sediment controls to minimize the discharge of pollutants.
- Construct sediment control BMPs (sediment ponds, traps, filters, etc.) as one of the first steps in grading. These BMPs shall be functional before other land disturbing activities take place.
- Minimize sediment discharges from the site. The design, installation, and maintenance of Construction SWPPP BMPs must address factors such as the amount, frequency, intensity, and duration of precipitation; the nature of resulting stormwater runoff; and soil characteristics, including the range of soil particle sizes expected to be present on the site.
- Direct stormwater runoff from disturbed areas through a sediment pond or other appropriate sediment removal BMP, before the runoff leaves a construction site or before discharge to an infiltration facility. Runoff from fully stabilized areas may be discharged without a sediment removal BMP, but must meet the flow control performance standard in Element #3.

- Locate BMPs intended to trap sediment on site in a manner to avoid interference with the movement of juvenile salmonids attempting to enter off-channel areas or drainages.
- Design outlet structures that withdraw impounded stormwater from the surface to avoid discharging sediment that is still suspended lower in the water column. Note: If the pond using the construction outlet control is used for permanent stormwater controls, the appropriate outlet structure must be installed after final stabilization.
- If installing a floating pump structure, include a stopper to prevent the pump basket from hitting the bottom of the pond.
- Seed and mulch earthen structures such as dams, dikes, and diversions according to the timing indicated in Element #5.
- Suggested BMPs:
 - BMP C232: Gravel Filter Berm
 - BMP C233: Silt Fence
 - BMP C234: Vegetated Strip
 - BMP C235: Wattles
 - BMP C240: Sediment Trap
 - BMP C241: Temporary Sediment Pond
 - BMP C250: Construction Stormwater Chemical Treatment
 - BMP C251: Construction Stormwater Filtration.

Element #5: Stabilize Soils

- Stabilize exposed and unworked soils by application of effective BMPs that prevent erosion. Applicable BMPs include, but are not limited to: temporary and permanent seeding, sodding, mulching, plastic covering, erosion control fabrics and matting, soil application of polyacrylamide (PAM), the early application of gravel base on areas to be paved, and dust control.
- **The city will inspect and must approve that final stabilization has been achieved in all disturbed areas before the release of financial guarantees (Volume I, Section 2.4.11).**
- Final stabilization means the completion of all soil-disturbing activities at the site and the establishment of a permanent vegetative cover, or equivalent permanent

stabilization measures (such as pavement, riprap, gabions, quarry spalls, ditch lining, or geotextiles) that will fully prevent erosion. Where the term “permanent vegetative cover” is used to describe vegetative cover or plantings, it shall be understood to mean that healthy vegetation covers 90 percent of exposed bare soil. The application of hydroseeding, even in conjunction with a bonded fiber matrix (BFM) or rolled erosion product, will not be accepted as fully established permanent erosion control before the necessary development and ground cover requirements of the plantings are met. The strong root structures of well-established vegetation are an essential mechanism in controlling soil erosion.

- Control stormwater volume and velocity within the site to minimize soil erosion.
- Control stormwater discharges, including both peak flow rates and total stormwater volume, to minimize erosion at outlets and to minimize downstream channel and stream bank erosion.
- Soils must not remain exposed and unworked for more than the time periods set forth below to prevent erosion.
 - During the dry season (May 1–September 30): 7 days
 - During the wet season (October 1–April 30): 2 days
- If rain is in the weather forecast, stabilize soils at the end of the work day regardless of season.
- Stabilize soil stockpiles from erosion; protect with sediment trapping measures; and where possible, locate away from storm drain inlets, waterways, and drainage channels.
- Minimize the amount of soil exposed during construction activity.
- Minimize the disturbance of steep slopes.
- Minimize soil compaction and, unless infeasible, preserve topsoil.
- Soil stabilization measures must be appropriate for the time of year, site conditions, estimated duration of use, and potential water quality impacts that stabilization agents may have on downstream waters or groundwater.
- Ensure that gravel base used for stabilization is clean, does not contain fines or sediment, and remains clean and within specifications prior to paving.
- **Note that everything above is describing what you do over the course of the project, but refer to Volume I for what you have to do before the project is accepted.**

- Suggested BMPs:
 - BMP C120: Temporary and Permanent Seeding
 - BMP C121: Mulching
 - BMP C122: Nets and Blankets
 - BMP C123: Plastic Covering
 - BMP C124: Sodding
 - BMP C125: Topsoiling/Composting
 - BMP C126: Polyacrylamide for Soil Erosion Protection
 - BMP C130: Surface Roughening
 - BMP C131: Gradient Terraces
 - BMP C140: Dust Control

Element #6: Protect Slopes

- Design and construct cut-and-fill slopes in a manner to minimize erosion.
- Consider soil type and its potential for erosion. Applicable practices include, but are not limited to, reducing continuous length of slope with terracing and diversions, reducing slope steepness, and roughening slope surfaces (for example, track walking).
- Divert off-site stormwater (run-on) or groundwater away from slopes and disturbed areas with interceptor dikes, pipes, and/or swales. Off-site stormwater must be managed separately from stormwater generated on the site.
- At the top of slopes, collect drainage in pipe slope drains or protected channels to prevent erosion.
- Temporary pipe slope drains must handle the peak flow from a 10-year, 24-hour storm event assuming a NRCS Type 1A rainfall distribution resolved to 10-minute time steps. Alternatively, the 10-year, 1-hour time step flow rate predicted by an approved continuous runoff model, increased by a factor of 1.6, may be used. If using an approved continuous runoff model with a 15-minute (or less) time step, no correction factor is required. The hydrologic analysis must use the existing land cover condition for predicting flow rates from tributary areas outside the project limits. For tributary areas on the project site, the analysis must use the temporary or permanent project land cover condition, whichever will produce the highest flow rates. If using the Western Washington Hydrology

Model (WWHM) to predict flows, bare soil areas shall be modeled as “landscaped” area.

- Permanent pipe slope drains shall be sized for the 100-year, 24-hour event.
- Provide drainage to remove groundwater intersecting the slope surface of exposed soil areas.
- Place excavated material on the uphill side of trenches, consistent with safety and space considerations.
- Place check dams at regular intervals within constructed channels that are cut down a slope.
- Stabilize soils on slopes, as specified in Element #5.
- BMP combinations are the most effective method of protecting slopes with disturbed soils. For example, use both mulching and straw erosion control blankets in combination.
- Suggested BMPs:
 - BMP C120: Temporary and Permanent Seeding
 - BMP C121: Mulching
 - BMP C122: Nets and Blankets
 - BMP C130: Surface Roughening
 - BMP C131: Gradient Terraces
 - BMP C200: Interceptor Dike and Swale
 - BMP C201: Grass-Lined Channels
 - BMP C203: Water Bars
 - BMP C204: Pipe Slope Drains
 - BMP C205: Subsurface Drains
 - BMP C206: Level Spreader
 - BMP C207: Check Dams
 - BMP C208: Triangular Silt Dike (Geotextile-Encased Check Dam).

Element #7: Protect Drain Inlets

- Protect all storm drain inlets made operable during construction so that stormwater runoff does not enter the conveyance system without first being filtered or treated to remove sediment.
- Clean or remove and replace inlet protection devices when sediment has filled one-third of the available storage (unless a different standard is specified by the product manufacturer).
- Inlets shall be inspected weekly at a minimum and daily during storm events.
- Where possible, protect all existing storm drain inlets so that stormwater runoff does not enter the conveyance system without first being filtered or treated to remove sediment.
- Keep all approach roads clean. Sediment and street wash wastewater shall be controlled as specified above in Element #2.
- Suggested BMPs:
 - BMP C220: Storm Drain Inlet Protection

Element #8: Stabilize Channels and Outlets

- Design, construct, and stabilize all on-site conveyance channels to prevent erosion from the following expected peak flows:
 - Channels must handle the peak flow from a 10-year, 24-hour storm event assuming a NRCS Type 1A rainfall distribution resolved to 10-minute time steps. Alternatively, the 10-year, 1-hour time step flow rate predicted by an approved continuous runoff model, increased by a factor of 1.6, may be used. If using an approved continuous runoff model with a 15-minute (or less) time step, no correction factor is required. The hydrologic analysis must use the existing land cover condition for predicting flow rates from tributary areas outside the project limits. For tributary areas on the project site, the analysis must use the temporary or permanent project land cover condition, whichever will produce the highest flow rates. If using the WWHM to predict flows, bare soil areas shall be modeled as “landscaped” area.
- Provide stabilization, including armoring material, adequate to prevent erosion of outlets, adjacent stream banks, slopes, and downstream reaches at the outlets of all conveyance systems.
- The preferred method for stabilizing channels is to completely line the channel with a blanket product first, then add check dams as necessary to function as an anchor and to slow the flow of water.

- Suggested BMPs:
 - BMP C202: Channel Lining
 - BMP C122: Nets and Blankets
 - BMP C207: Check Dams
 - BMP C209: Outlet Protection

Element #9: Control Pollutants

- Design, install, implement, and maintain effective pollution prevention measures to minimize the discharge of pollutants.
- Handle and dispose of all pollutants, including waste materials and demolition debris that occur on site in a manner that does not cause contamination of stormwater. Woody debris may be chopped and spread on site.
- Provide cover, containment, and protection from vandalism for all chemicals, liquid products, petroleum products, and other materials that have the potential to pose a threat to human health or the environment. On-site fueling tanks must include secondary containment. Secondary containment means placing tanks or containers within an impervious structure capable of containing 110 percent of the volume contained in the largest tank within the containment structure. Double-walled tanks do not require additional secondary containment.
- Conduct maintenance, fueling, and repair of heavy equipment and vehicles using spill prevention and control measures. Clean contaminated surfaces immediately following any spill incident.
- Conduct oil changes, hydraulic system drain down, solvent and de-greasing cleaning operations, fuel tank drain down and removal, and other activities that may result in discharge or spillage of pollutants to the ground or into stormwater runoff using spill prevention measures, such as drip pans.
- Discharge wheel wash or tire bath wastewater to a separate on-site treatment system that prevents discharge to surface water, such as closed-loop recirculation or upland land application, or to the sanitary sewer. For discharges to the sanitary sewer, permits must be obtained from the LOTT Clean Water Alliance at 360-528-5708. The city manages the collection and conveyance of wastewater to the LOTT Clean Water Alliance Wastewater Treatment Plant.
- For control of pests and weeds, develop and implement an integrated pest management plan and use pesticides only as a last resort (refer to Volume IV BMP A3.6). Apply fertilizers and pesticides in a manner and at application rates

that will not result in loss of chemical to stormwater runoff. Follow manufacturers' label requirements for application rates and procedures.

- Use BMPs to prevent contamination of stormwater runoff by pH-modifying sources. The sources for this contamination include, but are not limited to: bulk cement, cement kiln dust, fly ash, new concrete washing and curing waters, waste streams generated from concrete grinding and sawing, exposed aggregate processes, dewatering concrete vaults, concrete pumping and mixer washout waters.
- Adjust the pH of stormwater, if necessary, to prevent violations of the water quality standards.
- Ensure that washout of concrete trucks is performed off site or in designated concrete washout areas only. **It is illegal to** wash out concrete trucks onto the ground, or into storm drains, open ditches, streets, or streams. Do not dump excess concrete on site, except in designated concrete washout areas. Concrete spillage or concrete discharge to surface waters of the State is prohibited, and will result in clean-up requirements and financial penalties.
- Obtain written approval from Ecology before using chemical treatment other than carbon dioxide (CO₂) or dry ice to adjust pH.
- Wheel wash or tire bath wastewater shall not include wastewater from concrete washout areas.
- Do not use upland land applications for discharging wastewater from concrete washout areas.
- Clean contaminated surfaces immediately following any discharge or spill incident. Emergency repairs may be performed on site using temporary plastic placed beneath and, if raining, over the vehicle.
- Suggested BMPs:
 - BMP C151: Concrete Handling
 - BMP C152: Sawcutting and Surfacing Pollution Prevention
 - BMP C153: Material Delivery, Storage and Containment
 - BMP C154: Concrete Washout Area
 - BMP C250: Construction Stormwater Chemical Treatment
 - BMP C251: Construction Stormwater Filtration

- BMP C252: High pH Neutralization Using CO₂
- BMP C253: pH Control for High pH Water

See also Volume IV – Source Control BMPs.

Element #10: Control Dewatering

- Discharge foundation, vault, and trench dewatering water, which have characteristics similar to stormwater runoff at the site, into a controlled conveyance system before discharge to a sediment trap or sediment pond.
- Discharge clean, non-turbid dewatering water, such as well-point groundwater, to systems tributary to, or directly into surface waters of the State, as specified in Element #8, provided the dewatering flow does not cause erosion or flooding of receiving waters or interfere with the operation of the system. Do not route clean dewatering water through stormwater sediment ponds. Note that “surface waters of the State” may exist on a construction site as well as off site; for example, a creek running through a site.
- Highly turbid or contaminated dewatering water from construction equipment operation, clamshell digging, concrete tremie pour, or work inside a cofferdam, shall be handled separately from stormwater.
- Other treatment or disposal options include:
 - Infiltration.
 - Transport off site in a vehicle, such as a vacuum flush truck, for legal disposal in a manner that does not pollute waters of the State.
 - Ecology-approved on-site chemical treatment or other suitable treatment technologies.
 - Sanitary or combined sewer discharge with local sewer district approval, if there is no other option. For discharges to the sanitary sewer, permits must be obtained from the LOTT Clean Water Alliance at 360-528-5708. The city manages the collection and conveyance of wastewater to the LOTT Clean Water Alliance Wastewater Treatment Plant.
 - Use of a sedimentation bag with discharge to a ditch or swale for small volumes of localized dewatering.
 - Channels must be stabilized, as specified in Element #8.
 - Discharging sediment-laden (muddy) water into waters of the State likely constitutes violation of water quality standards for turbidity. The easiest way

to avoid discharging muddy water is through infiltration and preserving vegetation.

- Suggested BMPs:
 - BMP C203: Water Bars
 - BMP C236: Vegetative Filtration

Element #11: Maintain BMPs

- Maintain and repair all temporary and permanent Construction SWPPP BMPs as needed to ensure continued performance of their intended function in accordance with BMP specifications.
- Remove all temporary Construction SWPPP BMPs within 30 days after achieving final site stabilization or after the temporary BMPs are no longer needed. Note: Some temporary Construction SWPPP BMPs are biodegradable and designed to remain in place following construction, such as compost socks. Provide protection to all BMPs installed for the permanent control of stormwater from sediment and compaction. All BMPs that are to remain in place following completion of construction shall be examined and placed in full operating conditions. If sediment enters the BMPs during construction, it shall be removed; and the facility shall be returned to the conditions specified in the construction documents.
- Remove or stabilize trapped sediment on site, or remove sediment and dispose of it off site if sediment cannot be worked into the project site. Permanently stabilize disturbed soil resulting from removal of BMPs or vegetation.
- Suggested BMPs:
 - BMP C150: Materials on Hand
 - BMP C160: Certified Erosion and Sediment Control Lead

Element #12: Manage the Project

- Phase development projects to the maximum degree practicable and take into account seasonal work limits.
- All project sites that require a Construction SWPPP must have site inspections conducted by a CESCL. By the initiation of construction, the Construction SWPPP must identify the CESCL, who shall be present on site or on call at all times.
- All BMPs shall be included in the site inspection checklist within the SWPPP.

- Inspect, maintain, and repair all BMPs as needed to ensure continued performance of their intended function. Conduct site inspections and monitoring in accordance with all applicable city and CSWGP requirements.
- Maintain, update, and implement the Construction SWPPP in accordance with the CSWGP requirements and the requirements outlined in this Element (#12).

Additional Requirements for Managing the Site

- The CESCL or inspector (project sites less than 1 acre) must have the skills to assess the:
 - Site conditions and construction activities that could impact the quality of stormwater
 - Effectiveness of Construction SWPPP measures used to control the quality of stormwater discharges
- The CESCL must examine stormwater visually for the presence of suspended sediment, turbidity, discoloration, and oil sheen. They must evaluate the effectiveness of BMPs and determine if it is necessary to install, maintain, or repair BMPs to improve the quality of stormwater discharges.
- Based on the results of the inspection, construction site operators must correct the problems identified by:
 - Reviewing the Construction SWPPP for compliance with the 13 Construction SWPPP elements and making appropriate revisions within 7 days of the inspection.
 - Immediately begin the process of fully implementing and maintaining appropriate source control and/or treatment BMPs as soon as possible, addressing the problems no later than within 10 days of the inspection. If installation of necessary treatment BMPs is not feasible within 10 days, the construction site operator may request an extension within the initial 10-day response period.
 - Documenting BMP implementation and maintenance in the site log book (applies only to sites that have coverage under the CSWGP).
- The CESCL must inspect all areas disturbed by construction activities, all BMPs, and all stormwater discharge locations at least once every calendar week and within 24 hours of any discharge from the site. (For purposes of this condition, individual discharge events that last more than 1 day do not require daily inspections. For example, if a stormwater pond discharges continuously over the course of a week, only one inspection is required that week.) Note that additional requirements may apply per the project-specific SWPPP and/or permits, as

applicable. The CESCL may reduce the inspection frequency for temporarily stabilized, inactive sites to once every calendar month during the dry season only (May 1 through September 30).

- All inspection and monitoring activity shall be documented on the SWPPP inspection and monitoring forms.
- See BMP C160: Certified Erosion and Sediment Control Lead, for additional details and requirements.

Additional Requirements

- Phasing of Construction:
 - Phase development projects where feasible in order to prevent soil erosion and, to the maximum extent practical, prevent transporting sediment from the site during construction. Revegetate exposed areas and maintain that vegetation as an integral part of the clearing activities for any phase.
- Seasonal Work Limitations:
 - Construction activity presents an increased risk to water resources during the typically wet fall through spring periods in the Pacific Northwest. As such, particular attention must be given to proper selection, design, and installation of Construction SWPPP BMPs. From October 1 through April 30, clearing, grading, and other soil disturbing activities is permitted only if shown to the satisfaction of the city that the site operator will prevent silt-laden runoff from leaving the site through activities including but not limited to the following:
 - Compliance with Construction SWPPP Element #5 to Stabilize Soil and BMP Usage
 - Minimization of areas of site disturbance
 - Limitation of construction activities that will disturb soil or increase the potential for soil erosion and transport
 - Installation and regular inspection of all proposed Construction SWPPP BMPs.
 - Based on the information provided and/or local weather conditions, the city may expand or restrict the seasonal limitation on site disturbance.
 - The city may take enforcement action, such as a notice of violation, administrative order, fine/penalty, stop-work order, or correction notice under the following circumstances:

- If, during the course of any construction activity or soil disturbance sediment leaves the construction site causing a violation of the surface water quality standard.
- If clearing and grading limits or Construction SWPPP measures shown in the approved plan are not maintained.
- The following activities are exempt from the seasonal clearing and grading limitations:
 - Routine maintenance and necessary repair of Construction SWPPP BMPs
 - Routine maintenance of public facilities or existing utility structures that do not expose the soil or result in the removal of the vegetative cover to soil
 - Activities where there is 100 percent infiltration of surface water runoff within the site in approved and installed Construction SWPPP facilities. All infiltration facilities are subject to all infiltration facility requirements within all volumes of this manual. Note that special requirements apply to infiltration facilities near drinking water wells or within wellhead protection areas.
- Coordination with Utilities and Other Contractors:
 - The primary project applicant shall evaluate, with input from utilities and other contractors, the stormwater management requirements for the entire project area from duration through final stabilization, including the utilities, when preparing the Construction SWPPP.
- Inspection and Monitoring:
 - All BMPs must be inspected, maintained, and repaired as needed to ensure continued performance of their intended function.
 - Appropriate BMPs or design changes shall be implemented as soon as possible whenever inspection and/or monitoring reveals that the BMPs identified in the Construction SWPPP are inadequate, due to the actual discharge of/or potential to discharge a significant amount of any pollutant.
 - Inspection reports and daily logs must be available on site with the Construction SWPPP and shall be submitted to the city upon request at any time during the course of the project.

- Maintaining an Updated Construction SWPPP:
 - Retain the Construction SWPPP on site.
 - Modify the Construction SWPPP whenever there is a change in the design, construction, operation, or maintenance at the construction site that has, or could have, a significant effect on the discharge of pollutants to waters of the State.
 - The Construction SWPPP must be modified if, during inspections or investigations conducted by the owner/operator, or the applicable city or state regulatory authority, it is determined that the Construction SWPPP is ineffective in eliminating or significantly minimizing pollutants in stormwater discharges from the site. Modify the Construction SWPPP as necessary to include additional or modified BMPs designed to correct problems identified. Complete revisions to the Construction SWPPP within 7 days following the inspection.
- Suggested BMPs:
 - BMP C150: Materials on Hand
 - BMP C160: Certified Erosion and Sediment Control Lead
 - BMP C162: Scheduling

Element #13: Protect Low Impact Development BMPs

- Protect all Bioretention and Rain Garden BMPs from sedimentation through installation and maintenance of Construction SWPPP BMPs on portions of the site that drain into the Bioretention or Rain Garden BMPs.
- Restore the BMPs to their fully functioning condition if they accumulate sediment during construction. Restoring the BMP must include removal of sediment and any sediment-laden Bioretention or Rain Garden soils, and replacing the removed soils with soils meeting the design specification.
- Prevent compacting Bioretention and Rain Garden BMPs by excluding construction equipment and foot traffic. Protect completed lawn and landscaped areas from compaction due to construction equipment.
- Control erosion and avoid introducing sediment from surrounding land uses onto permeable pavements. Do not allow muddy construction equipment on the base material or pavement. Do not allow sediment-laden runoff onto permeable pavements, including permeable pavement subgrade, reservoir course, or wearing course.

- Pavements fouled with sediments or no longer passing an initial infiltration test must be cleaned using procedures shown in Volume V of this manual or the manufacturer's procedures.
- Keep all heavy equipment off existing soils under LID facilities that have been excavated to final grade to retain the infiltration rate of the soils.

See Section 3.3 for more details on protecting LID BMPs.

- Suggested BMPs:
 - BMP C102: Buffer Zone
 - BMP C103: High Visibility Fence
 - BMP C123: Plastic Covering
 - BMP C200: Interceptor Dike and Swale
 - BMP C201: Grass-Lined Channels
 - BMP C207: Check Dams
 - BMP C208: Triangular Silt Dike (TSD) (Geotextile-Encased Check Dam)
 - BMP C233: Silt Fence
 - BMP C234: Vegetated Strip
 - BMP C235: Wattles

Chapter 3 – Standards and Specifications for Best Management Practices

Best management practices are defined as schedules of activities, prohibitions of practices, maintenance procedures, and structural and/or managerial practices, that when used singly or in combination, prevent or reduce the release of pollutants to waters of Washington State. This chapter contains standards and specifications for temporary BMPs to be used as applicable during the construction phase of a project. Often using BMPs in combination is the best method to meet Construction SWPPP requirements.

None of the BMPs listed below will work successfully through the construction project without inspection and maintenance. Regular inspections to identify problems with the operation of each BMP, and the timely repair of any problems are essential to the continued operation of the BMPs.

Section 3.1 contains the standards and specifications for source control BMPs.

Section 3.2 contains the standards and specifications for runoff conveyance and treatment BMPs.

The standards for each individual BMP are divided into four sections:

1. Purpose
2. Conditions of Use
3. Design and Installation Specifications
4. Maintenance Standards

Note that the “conditions of use” always refer to site conditions. As site conditions change, BMPs must be changed to remain in compliance.

Section 3.3 contains required practices to protect LID BMPs during construction, per Minimum Requirement #2, Element #13.

3.1 Source Control BMPs

This section contains the standards and specifications for source control BMPs. Table 3.1 shows the relationship of the BMPs in Section 3.1 to the Construction SWPPP elements described in Section 2.3.3. Elements not shown on Table 3.1 are not satisfied through installation of source controls.

BMP or Element Name	Element #1 Preserve Vegetation/ Mark Clearing Limits	Element #2 Establish Construction Access	Element #5 Stabilize Soils	Element #6 Protect Slopes	Element #8 Stabilize Channels and Outlets	Element #9 Control Pollutants	Element #11 Maintain BMPs	Element #12 Manage the Project	Element #13 Protect Low Impact Development
BMP C101: Preserving Natural Vegetation	✓								
BMP C102: Buffer Zones	✓								✓
BMP C103: High Visibility Plastic or Metal Fence	✓								✓
BMP C105: Stabilized Construction Entrance/Exit		✓							
BMP C106: Wheel Wash		✓							
BMP C107: Construction Road/Parking Area Stabilization		✓							
BMP C120: Temporary and Permanent Seeding			✓	✓					
BMP C121: Mulching			✓	✓					
BMP C122: Nets and Blankets			✓	✓	✓				
BMP C123: Plastic Covering			✓	✓					
BMP C124: Sodding			✓	✓					
BMP C125: Topsoiling/Composting			✓						
BMP C126: Polyacrylamide for Soil Erosion Protection			✓						
BMP C130: Surface Roughening			✓	✓					
BMP C131: Gradient Terraces			✓	✓					
BMP C140: Dust Control			✓						
BMP C150: Materials On Hand							✓	✓	
BMP C151: Concrete Handling						✓			

Table 3.1 (continued). Source Control BMPs by SWPPP Element.

BMP or Element Name	Element #1 Preserve Vegetation/ Mark Clearing Limits	Element #2 Establish Construction Access	Element #5 Stabilize Soils	Element #6 Protect Slopes	Element #8 Stabilize Channels and Outlets	Element #9 Control Pollutants	Element #11 Maintain BMPs	Element #12 Manage the Project	Element #13 Protect Low Impact Development
BMP C152: Sawcutting and Surfacing Pollution Prevention						✓			
BMP C153: Material Delivery, Storage, and Containment						✓			
BMP C154: Concrete Washout Area						✓			
BMP C160: Certified Erosion and Sediment Control Lead							✓	✓	
BMP C162: Scheduling								✓	

BMP C101: Preserving Natural Vegetation and Topsoil

Purpose

The purpose of preserving natural vegetation and topsoil is to reduce erosion wherever practicable. Limiting site disturbance is the single most effective method for reducing erosion. For example, conifers can hold up to about 50 percent of all rain that falls during a storm. Up to 20 to 30 percent of this rain may never reach the ground but is taken up by the tree or evaporates. Another benefit is that the rain held in the tree can be released slowly to the ground after the storm.

Conditions of Use

- Natural vegetation must be preserved on steep slopes, near perennial and intermittent watercourses or swales, and on building sites in wooded areas.
- As required by the city or other agencies during the development review and permitting process.
- All projects shall preserve native topsoil to the maximum extent practicable. Where applicable, soil preservation shall be performed in accordance with the postconstruction soil quality and depth BMP in Volume V.

Design and Installation Specifications

Where feasible, all sites shall retain and protect vegetation and soil from compaction by fencing and keeping materials storage and equipment off these areas during construction.

Natural vegetation can be preserved in natural clumps or as individual trees, shrubs and vines.

The preservation of individual plants is more difficult because heavy equipment is generally used to remove unwanted vegetation. The points to remember when attempting to save individual plants are:

- Is the plant worth saving? Consider the location, species, size, age, vigor, and the work involved. City ordinances to save natural vegetation and trees should be reviewed.
- Fence or clearly mark areas around trees that are to be saved. It is preferable to keep ground disturbance away from the trees at least as far out as the dripline.

Plants need protection from three kinds of injuries:

- **Construction Equipment:** This injury can be above or below the ground level. Damage results from scarring, cutting of roots, and compaction of the soil. Placing a fenced buffer zone around plants to be saved prior to construction can prevent construction equipment injuries.

- **Grade Changes:** Changing the natural ground level will alter grades, which affects the plant's ability to obtain the necessary air, water, and minerals. Minor fills usually do not cause problems although sensitivity between species does vary and should be checked. Trees can typically tolerate fill of 6 inches or less. For shrubs and other plants, the fill should be less.

When there are major changes in grade, it may become necessary to supply air to the roots of plants. This can be done by placing a layer of gravel and a tile system over the roots before the fill is made. A tile system protects a tree from a raised grade. The tile system should be laid out on the original grade leading from a dry well around the tree trunk. The system should then be covered with small stones to allow air to circulate over the root area.

Lowering the natural ground level can seriously damage trees and shrubs. The highest percentage of the plant roots are in the upper 12 inches of the soil and cuts of only 2 to 3 inches can cause serious injury. To protect the roots, it may be necessary to terrace the immediate area around the plants to be saved. If roots are exposed, construction of retaining walls may be needed to keep the soil in place. Plants can also be preserved by leaving them on an undisturbed, gently sloping mound. To increase the chances for survival, it is best to limit grade changes and other soil disturbances to areas outside the dripline of the plant.

- **Excavations:** Protect trees and other plants when excavating for drainfields, power, water, and sewer lines. Where possible, the trenches should be routed around trees and large shrubs. When this is not possible, it is best to tunnel under them (except for drainfields/infiltration facilities, which would require tree removal). This can be done with hand tools or with power augers. If it is not possible to route the trench around plants to be saved, then the following should be observed:
 - Cut as few roots as possible. When you must cut, cut clean. Paint cut root ends with a wood dressing like asphalt base paint if roots will be exposed for more than 24 hours.
 - Backfill the trench as soon as possible.
 - Tunnel beneath root systems as close to the center of the main trunk to preserve most of the important feeder roots.

Some problems that can be encountered with a few specific trees are:

- Maple, dogwood, red alder, western hemlock, western red cedar, and Douglas-fir do not readily adjust to changes in environment, and special care should be taken to protect these trees.
- The windthrow hazard of Pacific silver fir and Pacific madrona is high, while that of western hemlock is moderate. The danger of windthrow increases where dense

stands have been thinned. Other species (unless they are on shallow, wet soils less than 20 inches deep) have a low windthrow hazard.

- Cottonwoods, maples, and willows have water-seeking roots. These can cause trouble in sewer lines and infiltration fields. On the other hand, they thrive in high moisture conditions that other trees would not.
- Thinning operations in pure or mixed stands of grand fir, Pacific silver fir, noble fir, Sitka spruce, western red cedar, western hemlock, Pacific dogwood, and red alder can cause serious disease problems. Disease can become established through damaged limbs, trunks, roots, and freshly cut stumps. Diseased and weakened trees are also susceptible to insect attack.

Maintenance Standards

- Inspect flagged and/or fenced areas regularly to make sure flagging or fencing has not been removed or damaged. If the flagging or fencing has been damaged or visibility reduced, it shall be repaired or replaced immediately and visibility restored.
- If tree roots have been exposed or injured, “prune” cleanly with an appropriate pruning saw or loppers directly above the damaged roots and recover with native soils. Treatment of sap flowing trees (fir, hemlock, pine, soft maples) is not advised as sap forms a natural healing barrier.

BMP C102: Buffer Zones

Purpose

Delineation of an area to remain undisturbed or strip of natural vegetation or an established suitable planting that will provide a living filter to reduce soil erosion and runoff velocities.

Conditions of Use

Natural buffer zones are used along streams, wetlands and other bodies of water that need protection from erosion and sedimentation. Vegetative buffer zones can be used to protect natural swales and can be incorporated into the natural landscaping of an area.

Critical-area buffers shall not be used as sediment treatment areas. These buffers shall remain completely undisturbed. The city may expand the buffer widths temporarily to allow the use of the expanded area for improved removal/filtration of sediment in any surface flow towards the buffer.

Design and Installation Specifications

- Preserving natural vegetation or plantings in clumps, blocks, or strips is generally the easiest and most successful method.
- Leave all unstable steep slopes in natural vegetation.
- Mark clearing limits and keep all equipment and construction debris out of the natural areas and buffer zones. High visibility fencing is the most effective method in protecting sensitive areas and buffers. Alternatively, wire-backed silt fence on steel posts is marginally effective. Flagging alone is typically not effective.
- Keep all excavations outside the dripline of trees and shrubs.
- Do not push debris or extra soil into the buffer zone area because it will cause damage from burying and smothering.
- Vegetative buffer zones for streams, lakes or other waterways shall be established by the city or other state or federal permits or approvals.

Maintenance Standards

- Inspect the area frequently to make sure fencing or flagging remains in place and remains undisturbed. Replace all damaged fencing or flagging immediately.

BMP C103: High Visibility Fence

Purpose

Fencing is intended to:

- Restrict clearing to approved limits
- Prevent disturbance of sensitive areas, their buffers, and other areas required to be left undisturbed
- Limit construction traffic to designated construction entrances, exits or internal roads
- Protect areas where marking with flagging/survey tape may not provide adequate protection

Conditions of Use

To establish clearing limits plastic, fabric, or metal fence may be used:

- At the boundary of sensitive areas, their buffers, and other areas required to be left uncleared.
- As necessary to control vehicle access to and on the site.

Design and Installation Specifications

- High visibility plastic fence shall be composed of a high-density polyethylene material and shall be at least 4 feet in height. Posts for the fencing shall be steel or wood and placed every 6 feet on center (maximum) or as needed to ensure rigidity. The fencing shall be fastened to the post every 6 inches with a polyethylene tie. On long continuous lengths of fencing, a tension wire or rope shall be used as a top stringer to prevent sagging between posts. The fence color shall be high visibility orange. The fence tensile strength shall be 360 pounds per foot using the American Society for Testing and Materials (ASTM) D4595 testing method.
- If appropriate, install fabric silt fence in accordance with BMP C233 to act as high visibility fence. Except that the silt fence shall be at least 3 feet high and must be highly visible to meet the requirements of this BMP.
- Metal fences are the least preferred but might be appropriate to address security concerns. Metal fencing shall be designed and installed according to the manufacturer's specifications.

- Metal fences shall be at least 4 feet high and must be highly visible.
- Fences shall not be wired or stapled to trees.

Maintenance Standards

- If the fence has been damaged or visibility reduced, it shall be repaired or replaced immediately and visibility restored.

BMP C105: Stabilized Construction Entrance/Exit

Purpose

Stabilized Construction entrances are established to reduce the amount of sediment transported onto paved roads by vehicles or equipment. This is done by constructing a stabilized pad of quarry spalls at entrances and exits for construction sites.

Conditions of Use

Construction entrances shall be stabilized wherever traffic will be entering or leaving a construction site if paved roads or other paved areas are within 1,000 feet of the site.

For residential construction, provide stabilized construction entrances for each residence, rather than only at the main subdivision entrance. Stabilized surfaces shall be of sufficient length/width to provide vehicle access, based on lot size and configuration.

On large commercial, highway, and road projects, the designer should include enough extra materials in the contract to allow for additional stabilized entrances not shown in the initial Construction SWPPP. It is difficult to determine exactly where access to these projects will take place; additional materials will enable the contractor to install them where needed.

Design and Installation Specifications

- See Figure 3.1 for details. Note: the 100-foot minimum length of the entrance shall be reduced to the maximum practicable size when the size or configuration of the site does not allow the full length (100 feet).
- Construct stabilized construction entrances with a 12-inch-thick pad of 4-inch to 8-inch quarry spalls, a 4-inch course of asphalt treated base (ATB), or use existing pavement. For single-family residential lots, the pad may be reduced in length to fit site, to no less than 20 feet long, and in depth, to 6 inches thick with 4-inch to 6-inch quarry spalls, provided that performance standards are still met.
- Do not use crushed concrete, cement, or calcium chloride for construction entrance stabilization because these products raise pH levels in stormwater and concrete discharge to surface waters of the State is prohibited

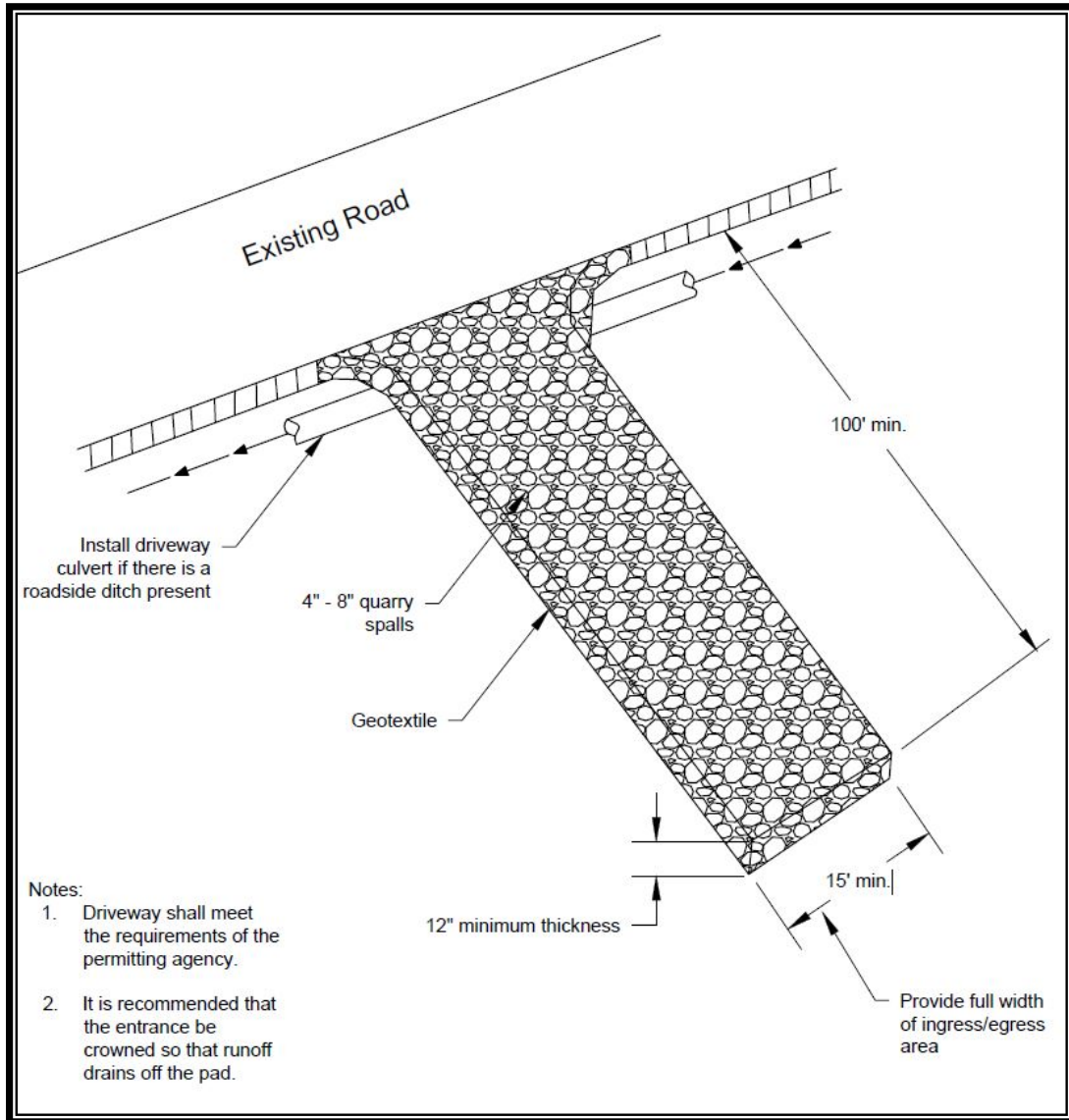

Figure 3.1 Stabilized Construction Entrance.

- A separation geotextile shall be placed under the spalls to prevent fine sediment from pumping up into the rock pad. The geotextile shall meet the following standards:
 - Grab Tensile Strength (ASTM D4751): 200 psi minimum
 - Grab Tensile Elongation (ASTM D4632): 30 percent maximum
 - Mullen Burst Strength (ASTM D3786-80a): 400 psi minimum
 - AOS (ASTM D4751): 20 to 45 (U.S. standard sieve size).

- Fencing (see BMP C103) shall be installed as necessary to restrict traffic to the construction entrance.
- Whenever possible, the entrance shall be constructed on a firm, compacted subgrade. This can substantially increase the effectiveness of the pad and reduce the need for maintenance.

Maintenance Standards

- Quarry spalls shall be added if the pad is no longer in accordance with the specifications.
- Construction entrances should avoid crossing existing sidewalks and back of walk drains, if possible. If a construction entrance must cross a sidewalk or back of walk drain, the full length of the sidewalk and back of walk drain must be covered and protected from sediment leaving the site.
- If the entrance is not preventing sediment from being tracked onto pavement, then alternative measures to keep the streets free of sediment shall be used. This may include replacement/cleaning of the existing quarry spalls, street sweeping, an increase in the dimensions of the entrance, or the installation of a wheel wash.
- Any sediment that is tracked onto pavement shall be removed by shoveling or street sweeping. The sediment collected by sweeping shall be removed or stabilized on site. The pavement shall not be cleaned by washing down the street, except when high efficiency sweeping is ineffective and there is a threat to public safety. If it is necessary to wash the streets, the construction of a small sump to contain the wash water may be required. The sediment would then be washed into the sump where it can be controlled.
- Perform street sweeping by hand or with a high efficiency sweeper. Do not use a non-high efficiency mechanical sweeper as these sweepers create dust and throw soil into nearby storm systems or conveyance ditches.
- Any quarry spalls that are loosened from the pad, which end up on the roadway shall be removed immediately.
- If vehicles are entering or exiting the site at points other than the construction entrance(s), fencing (see BMP C103) shall be installed to control traffic.
- Upon project completion and site stabilization, all construction accesses intended as permanent access for maintenance shall be permanently stabilized.

Approved as Equivalent

Ecology has approved specific products as able to meet the requirements of BMP C105. However, the products did not pass through the Technology Assessment Protocol – Ecology (TAPE) process. The list of products is available on Ecology’s web site at www.ecy.wa.gov/programs/wq/stormwater/newtech/equivalent.html.

If a project wishes to use any of the “approved as equivalent” BMPs in the City of Tumwater, the project owner or representative must obtain approval for use of the BMP from the city on a case-by-case basis (i.e., for each project or site) before use.

BMP C106: Wheel Wash

Purpose

Wheel washes reduce the amount of sediment transported onto paved roads by motor vehicles.

Conditions of Use

When a stabilized construction entrance/exit (see BMP C105) is not preventing sediment from being tracked onto pavement.

- Wheel washing is generally an effective BMP when installed with careful attention to topography. For example, a wheel wash can be detrimental if installed at the top of a slope abutting a right-of-way where the water from the dripping truck can run unimpeded into the street.
- Pressure washing combined with an adequately sized and surfaced pad with direct drainage to a large 10-foot by 10-foot sump can be very effective.

Design and Installation Specifications

- Suggested details are shown in Figure 3.2. A minimum of 6 inches of asphalt treated base over crushed base material or 8 inches over a good subgrade is recommended to pave the wheel wash.
- Discharge wheel wash or tire bath wastewater to a separate on-site treatment system that prevents discharge to surface water, such as closed-loop recirculation or upland land application, or to the sanitary sewer with city approval. For discharges to the sanitary sewer, permits must be obtained from the LOTT Clean Water Alliance at 360-528-5708. The city manages the collection and conveyance of wastewater to the LOTT Clean Water Alliance Wastewater Treatment Plant.
- Wheel wash or tire bath wastewater shall not include wastewater from concrete washout areas.
- Use a low clearance truck to test the wheel wash before paving. Either a belly dump or lowboy will work well to test clearance.
- Keep the water level from 12 to 14 inches deep to avoid damage to truck hubs and filling the truck tongues with water.
- Midpoint spray nozzles are only needed in extremely muddy conditions.
- Wheel wash systems shall be designed with a small grade change, 6 to 12 inches for a 10-foot-wide pond, to allow sediment to flow to the low side of pond to help prevent resuspension of sediment. A drainpipe with a 2- to 3-foot riser should be installed on the low side of the pond to allow for easy cleaning and refilling. Polymers may be used to promote coagulation and flocculation in a closed-loop system.

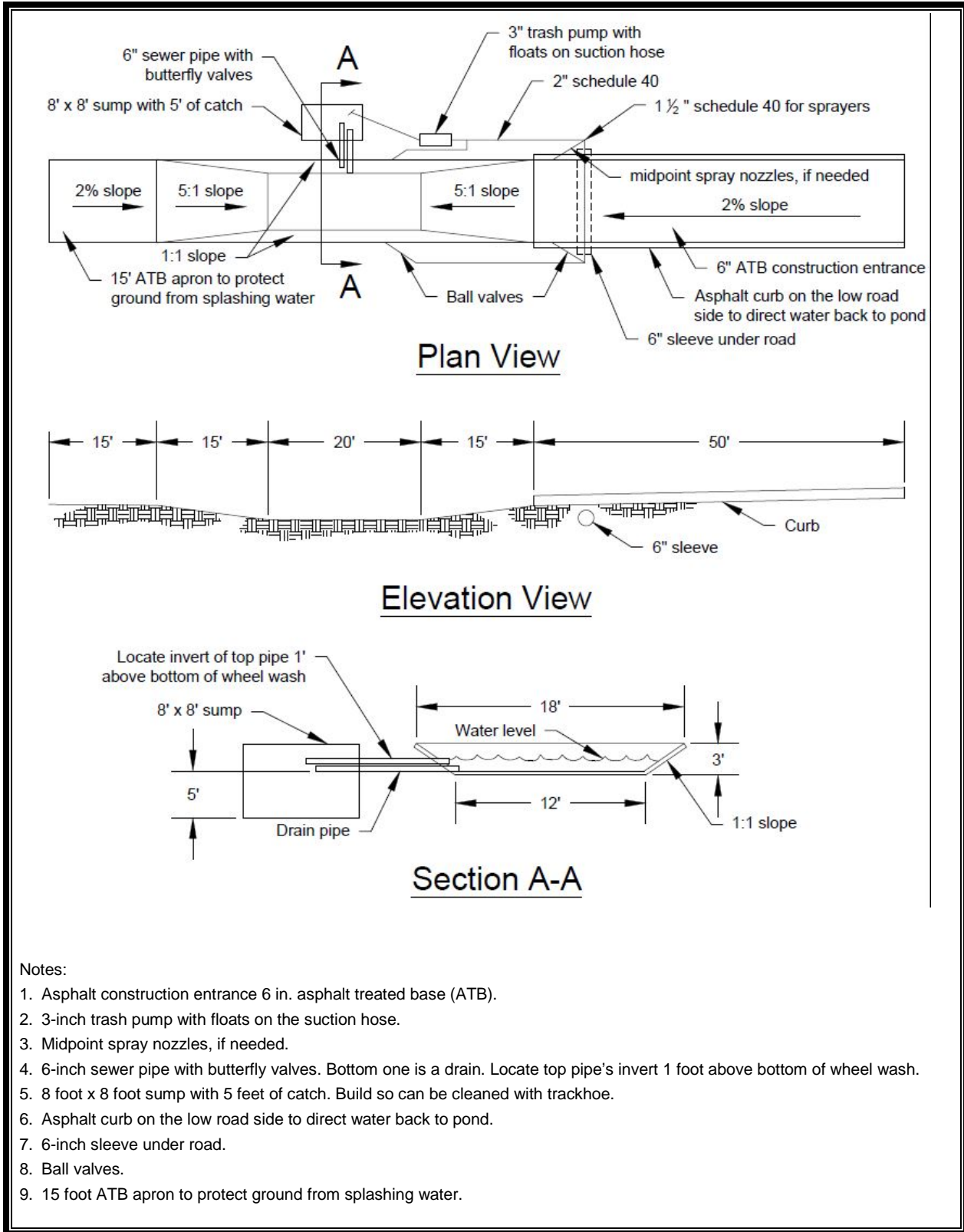

Figure 3.2. Wheel Wash.

Maintenance Standards

- The wheel wash should start out the day with fresh water.
- The washwater should be changed a minimum of once per day. On large earthwork jobs where more than 10 to 20 trucks per hour are expected, the washwater will need to be changed more often.

BMP C107: Construction Road/Parking Area Stabilization

Purpose

Stabilizing subdivision roads, parking areas, and other on-site vehicle transportation routes immediately after grading reduces erosion caused by construction traffic or runoff.

Conditions of Use

- Roads or parking areas shall be stabilized wherever they are constructed, whether permanent or temporary, for use by construction traffic.
- High Visibility Fencing (see BMP C103) shall be installed, if necessary, to limit the access of vehicles to only those roads and parking areas that are stabilized.

Design and Installation Specifications

- On areas that will receive asphalt as part of the project, install the first lift as soon as possible. However, this is not appropriate when final surface is porous/permeable.
- A 6-inch depth of 2- to 4-inch crushed rock, gravel base, or crushed surfacing base course shall be applied immediately after grading or utility installation. A 4-inch course of asphalt treated base (ATB) may also be used, or the road/parking area may be paved. If the area will not be used for permanent roads, parking areas, or structures, a 6-inch depth of hog fuel may also be used, but this is likely to require more maintenance. Whenever possible, construction roads and parking areas shall be placed on a firm, compacted subgrade.
- Temporary road gradients shall not exceed 15 percent. Roadways shall be carefully graded to drain. Drainage ditches shall be provided on each side of the roadway in the case of a crowned section, or on one side in the case of a super-elevated section. Drainage ditches shall be directed to a sediment control BMP.
- Rather than relying on ditches, it may also be possible to grade the road so that runoff sheet-flows into a heavily vegetated area with a well-developed topsoil. Landscaped areas are not adequate. If this area has at least 50 feet of vegetation that water can flow through, then it is generally preferable to use the vegetation to treat runoff, rather than a sediment pond or trap. The 50 feet shall not include wetlands or their buffers. If runoff is allowed to sheetflow through adjacent vegetated areas, it is vital to design the roadways and parking areas so that no concentrated runoff is created.
- Storm drain inlets shall be protected to prevent sediment-laden water entering the stormwater drainage system (see BMP C220).

Maintenance Standards

- Inspect stabilized areas regularly, especially after large storm events.
- Crushed rock, gravel base, hog fuel, etc., shall be added as required to maintain a stable driving surface and to stabilize any areas that have eroded.
- Following construction, these areas shall be restored to preconstruction condition or better to prevent future erosion.
- Perform street cleaning at the end of each day or more often if necessary.

BMP C120: Temporary and Permanent Seeding

Purpose

Seeding reduces erosion by stabilizing exposed soils with a well-established vegetative cover. This is one of the most effective methods of reducing erosion.

Conditions of Use

- Use seeding throughout the project on disturbed areas that have reached final grade or that will remain unworked for more than 30 days.
- The optimum seeding windows for western Washington are April 1 through June 30 and September 1 through October 1.
- Between July 1 and August 30 seeding requires irrigation until 75 percent grass cover is established.
- Between October 1 and March 30 seeding requires a cover of mulch with straw or an erosion control blanket until 75 percent grass cover is established.
- Where the term “fully established” is used to describe vegetative cover or plantings, it shall be understood to mean that healthy vegetation covers 90 percent of exposed soil.
- Inspect all disturbed areas in late August to early September and complete all seeding by the end of September. Otherwise, vegetation will not establish itself enough to provide more than average protection.
- Mulch is required at all times for seeding because it protects seeds from heat, moisture loss, and transport due to runoff. Mulch can be applied on top of the seed or simultaneously by hydroseeding. See BMP C121: Mulching, for specifications.
- Seed and mulch all disturbed areas not otherwise vegetated at final site stabilization. Final stabilization means the completion of all soil disturbing activities at the site and the establishment of a permanent vegetative cover, or equivalent permanent stabilization measures (such as pavement, riprap, gabions, or geotextiles) that will prevent erosion.

Design and Installation Specifications

- Seed retention/detention ponds as required.
- Install channels intended for vegetation before starting major earthwork, hydroseeded with a bonded fiber matrix (BFM). For vegetated channels that will have high flows, install erosion control blankets over hydroseed. Before allowing water to flow in vegetated channels, establish 75 percent vegetation cover. If

vegetated channels cannot be established by seed before water flow, install sod in the channel bottom—over hydromulch and erosion control blankets. Sod may be used for lining ditches to prevent erosion, but it will provide little water quality benefit during the wet season.

- Confirm the installation of all required surface water control measures to prevent seed from washing away.
- The seedbed should be firm and rough. All soil shall be roughened no matter what the slope. If compaction is required for engineering purposes, slopes must be track walked before seeding. Backblading or smoothing of slopes greater than 4:1 is not allowed if they are to be seeded.
- New and more effective restoration-based landscape practices rely on deeper incorporation than that provided by a simple single-pass rototilling treatment. Wherever practical the subgrade should be initially ripped to improve long-term permeability, infiltration, and water inflow qualities. At a minimum, permanent areas shall use soil amendments to achieve organic matter and permeability performance defined in engineered soil/landscape systems. For systems that are deeper than 8 inches the rototilling process should be done in multiple lifts, or the prepared soil system shall be prepared properly and then placed to achieve the specified depth.
- Organic matter is the most appropriate form of “fertilizer” because it provides nutrients (including nitrogen, phosphorus, and potassium) in the least water-soluble form. A natural system typically releases 2 to 10 percent of its nutrients annually.
- In general, 10-4-6 N-P-K (nitrogen-phosphorus-potassium) fertilizer can be used at a rate of 90 pounds per acre. Slow-release fertilizers shall be used because they are more efficient and have fewer environmental impacts. It is recommended that areas being seeded for final landscaping conduct soil tests to determine the exact type and quantity of fertilizer needed. This will prevent the over-application of fertilizer. If fertilizer is added to a hydromulch machine, it shall not be agitated for more than 20 minutes, since this can destroy the slow-release coating.
- There are numerous products available on the market that take the place of chemical fertilizers. These include several with seaweed extracts that are beneficial to soil microbes and organisms. If 100 percent cottonseed meal is used as the mulch in hydroseed, chemical fertilizer may not be necessary. Cottonseed meal is a good source of long-term, slow-release, available nitrogen.
- Hydroseed applications shall include a minimum of 1,500 pounds per acre of mulch with 3 percent tackifier. See BMP C121: Mulching, for specifications.
- On steep slopes, BFM or mechanically bonded fiber matrix (MBFM) products should be used. BFM/MBFM products are applied at a minimum rate of 3,000 pounds per acre of mulch with approximately 10 percent tackifier.

Application is made so that a minimum of 95 percent soil coverage is achieved. Numerous products are available commercially and should be installed per manufacturer's instructions. Most products require 24 to 36 hours to cure before a rainfall and cannot be installed on wet or saturated soils. Generally, these products come in 40 to 50 pound bags and include all necessary ingredients except for seed and fertilizer.

- In most cases, the shear strength of blankets is not a factor when used on slopes, only when used in channels. BFMs and MBFMs are good alternatives to blankets in most situations where vegetation establishment is the goal.
- Areas that will have seeding only and not landscaping may need compost or meal-based mulch included in the hydroseed in order to establish vegetation. Re-install native topsoil on the disturbed soil surface before application. See also postconstruction soil quality and depth in Volume V, Chapter 6.
- When installing seed via hydroseeding operations, only about one-third of the seed actually ends up in contact with the soil surface. This reduces the ability to establish a good stand of grass quickly. To overcome this, consider increasing seed quantities by up to 50 percent.
- Enhance vegetation establishment by dividing the hydromulch operation into two phases:
 1. Phase 1 – Install all seed and fertilizer with 25 to 30 percent mulch and tackifier onto soil in the first lift;
 2. Phase 2 – Install the rest of the mulch and tackifier over the first lift.

Or, enhance vegetation by:

1. Installing the mulch, seed, fertilizer, and tackifier in one lift.
2. Spread or blow straw over the top of the hydromulch at a rate of 800 to 1,000 pounds per acre.
3. Hold straw in place with a standard tackifier.

Both of these approaches will increase cost moderately but will greatly improve and enhance vegetative establishment. The increased cost may be offset by the reduced need for:

- Irrigation
- Reapplication of mulch
- Repair of failed slope surfaces

This technique works with standard hydromulch (1,500 pounds per acre minimum) and BFM or MBFM (3,000 pounds per acre minimum).

- Seed may be installed by hand if:
 - Temporary and covered by straw, mulch, or topsoil.
 - Permanent in small areas (usually less than 1 acre) and covered with mulch, topsoil, or erosion blankets.

- The seed mixes listed in the tables below include recommended mixes for both temporary and permanent seeding. These mixes, with the exception of the wetland mix and temporary erosion control mix, shall be applied at a rate of 80 to 100 seeds per square foot. Wet sites should apply 120 to 150 seeds per square foot. Local suppliers should be consulted for information on current pure live seed (PLS) rates and species specific seeds per pound to determine seed mix PLS pounds of seed per acre. The appropriate mix depends on a variety of factors, including exposure, soil type, slope, and expected foot traffic. Alternative seed mixes approved by the city may be used.

- Other mixes may be appropriate, depending on the soil type and hydrology of the area. Consult the local revegetation experts or the local conservation district for their recommendations because the appropriate mix depends on a variety of factors, including location, exposure, soil type, slope, and expected foot traffic. Alternative seed mixes approved by the city may be used.

Table 3.2 presents the standard mix for those areas where a temporary or permanent vegetative cover is required. The mix assumes a desired 150 seeds per square foot and should be applied at approximately 37 pounds of pure live seed per acre.

Table 3.2. Temporary Erosion Control Seed Mix.				
Common Name	Species	Percent Species Composition	Desired Seeds Per Square Foot	Pounds Pure Live Seed per Acre
Spike bentgrass	<i>Agrostis exarata</i>	6	9	0.1
California brome	<i>Bromus carinatus</i>	15	23	9.8
Tufted hairgrass	<i>Deschampsia cespitosa</i>	15	23	0.4
Blue wildrye	<i>Elymus glaucus</i>	18	27	10.7
California oatgrass	<i>Danthonia californica</i>	18	27	5.6
Native red fescue	<i>Festuca rubra var. rubra</i>	18	27	2.4
Meadow barley	<i>Hordeum brachyantherum</i>	10	15	7.7
Total			151	36.7

Table 3.3 provides a recommended option for landscaping seed. It assumes a desired 100 seeds per square foot and should be applied at 18 pounds of pure live seed per acre.

Table 3.3. Landscaping Seed Mix.				
Common Name	Species	Percent Species Composition	Desired Seeds Per Square Foot	Pounds Pure Live Seed per Acre
Sideoats grama	<i>Bouteloua curtipendula</i>	20	30	6.8
California oatgrass	<i>Danthonia californica</i>	20	30	6.2
Native red fescue	<i>Festuca rubra var. rubra</i>	30	45	3.9
Prairie Junegrass	<i>Koeleria macrantha</i>	30	45	0.8
Total			150	17.7

The turf seed mix in Table 3.4 is for dry situations where there is little need for water. The advantage is that this mix requires very little maintenance.

Table 3.4. Low-Growing Turf Seed Mix.				
Common Name	Species	Percent Species Composition	Desired Seeds Per Square Foot	Pounds Pure Live Seed per Acre
Hard fescue	<i>Festuca brevipila</i>	25	20	1.5
Sheep fescue	<i>Festuca ovina</i>	30	24	1.5
Native red fescue	<i>Festuca rubra var. rubra</i>	25	20	1.7
Prairie Junegrass	<i>Koeleria macrantha</i>	20	16	0.3
Total			80	5

Table 3.5 presents a mix recommended for bioswales and other intermittently wet areas. The mix assumes a desired 150 seeds per square foot and approximately 29 pounds of pure live seed per acre. Sod shall generally not be used for bioswales because the seed mix is inappropriate for this application. Sod may be used for lining ditches to prevent erosion, but it will provide little water quality benefit during the wet season.

Table 3.5. Bioswale Seed Mix.				
Common Name	Species	Percent Species Composition	Desired Seeds Per Square Foot	Pounds Pure Live Seed per Acre
American sloughgrass	<i>Beckmannia syzigachne</i>	15	23	0.9
Tufted hairgrass	<i>Deschampsia cespitosa</i>	20	30	0.5
Blue wildrye	<i>Elymus glaucus</i>	18	27	10.7
Native red fescue	<i>Festuca rubra var. rubra</i>	20	30	2.6
Meadow barley	<i>Hordeum brachyantherum</i>	12	18	9.2
Northwestern mannagrass	<i>Glyceria occidentalis</i>	15	23	4.9
Total			151	28.8

The seed mix in Table 3.6. is a recommended low-growing, non-invasive seed mix appropriate for very wet areas that are not regulated wetlands. Other mixes may be appropriate, depending on the soil type and hydrology of the area. This mixture assumes a target goal of 150 seeds per square foot and should be applied at a rate of 36 pounds per acre. Consult terms of the HPA permit for seed mixes in wetlands.

Table 3.6. Low-Growing, Wet Area Seed Mix.*				
Common Name	Species	Percent Species Composition	Desired Seeds Per Square Foot	Pounds Pure Live Seed per Acre
California brome	<i>Bromus carinatus</i>	15	23	9.8
Columbia brome	<i>Bromus vulgaris</i>	18	27	8.1
Tufted hairgrass	<i>Deschampsia cespitosa</i>	15	23	0.4
California oatgrass	<i>Danthonia californica</i>	15	23	4.7
Native red fescue	<i>Festuca rubra var. rubra</i>	17	26	2.2
Western manna grass	<i>Glyceria occidentalis</i>	10	15	3.3
Meadow barley	<i>Hordeum brachyantherum</i>	10	15	7.7
Total			152	36.2

*Modified Briargreen, Inc. Hydroseeding Guide Wetlands Seed Mix.

The meadow seed mix in Table 3.7 is recommended for areas that will be maintained infrequently or not at all and where colonization by native plants is desirable. Likely applications include rural road and utility right-of-way. Seeding should take place in September or very early October in order to obtain adequate establishment prior to the winter months. This seed mix assumes a target goal of 120 seeds per square foot and an application rate of 25 pounds of pure live seed per acre.

Table 3.7. Meadow Seed Mix.				
Common Name	Species	Percent Species Composition	Desired Seeds Per Square Foot	Pounds Pure Live Seed per Acre
Common yarrow	<i>Achillea millefolium</i>	4	5	0.1
Pearly everlasting	<i>Anaphalis margaritacea</i>	1	1	0.0
California brome	<i>Bromus carinatus</i>	15	18	7.8
California oatgrass	<i>Danthonia californica</i>	15	18	3.7
Blue wildrye	<i>Elymus glaucus</i>	16	19	7.6
Idaho fescue	<i>Festuca idahoensis</i>	15	18	1.7
Native red fescue	<i>Festuca rubra var. rubra</i>	18	22	1.9
Sickle keeled lupine	<i>Lupinus albicaulis</i>	1	1	2.2
Fowl bluegrass	<i>Poa palustris</i>	15	18	0.4
Total			120	25.4

Maintenance Standards

- Reseed any seeded areas that fail to establish at least 80 percent cover (100 percent cover for areas that receive sheet or concentrated flows). If reseeding is ineffective, an alternate method, such as sodding, mulching, or nets/blankets, shall be used. If winter weather prevents adequate grass growth, this time limit may be relaxed at the discretion of the city when sensitive areas would otherwise be protected.
- Reseed and protect by mulch any areas that experience erosion after achieving adequate cover. Reseed and protect by mulch any eroded area.
- Supply seeded areas with adequate moisture, but do not water to the extent that it causes runoff.

Approved as Equivalent

Ecology has approved specific products as able to meet the requirements of BMP C120. However, the products did not pass through the TAPE process. The list of products is available on Ecology's web site at

<www.ecy.wa.gov/programs/wq/stormwater/newtech/equivalent.html>.

If a project wishes to use any of the "approved as equivalent" BMPs in the City of Tumwater, the project owner or representative must obtain approval for use of the BMP from the city on a case-by-case basis (i.e., for each project or site) before use.

BMP C121: Mulching

Purpose

Mulching soils provides immediate temporary protection from erosion. Mulch also enhances plant establishment by conserving moisture, holding fertilizer, seed, and topsoil in place, and moderating soil temperatures. There is an enormous variety of mulches that can be used. This section discusses only the most common types of mulch.

Conditions of Use

As a temporary cover measure, mulch shall be used:

- On disturbed areas that require temporary stabilization, that are not covered with blankets, sod, or plastic covering.
- At all times for seeded areas, especially during the wet season and during the hot summer months.
- During the wet season on slopes steeper than 3H:1V with more than 10 feet of vertical relief.
- Mulch may be applied at any time of the year.
- Straw mulch must be refreshed frequently, and hydromulches per the manufacturer's recommendations.
- For seeded areas, mulch may be made up of 100 percent: cottonseed meal; fibers made of wood, recycled cellulose, hemp, kenaf; compost; or blends of these. Tackifier shall be plant-based, such as guar or alpha plantago, or chemical-based such as polyacrylamide or polymers. Any mulch or tackifier product used shall be installed per manufacturer's instructions. Generally, mulches come in 40- to 50-pound bags. Seed and fertilizer are added at time of application.

Design and Installation Specifications

For mulch materials, application rates, and specifications, see Table 3.8. Always use a 2-inch minimum mulch thickness; increase the thickness until the ground is 95 percent covered (i.e., not visible under the mulch layer). Note: Thicknesses may be increased for disturbed areas in or near sensitive areas or other areas highly susceptible to erosion.

Where the option of "compost" is selected, it must be a coarse compost that meets the following size gradations when tested in accordance with the U.S. Composting Council "Test Methods for the Examination of Compost and Composting" Test Method 02.02-B.

Table 3.8. Mulch Standards and Guidelines.

Mulch Material	Quality Standards	Application Rates	Remarks
Straw	WSDOT Standard Specifications for Straw	2" to 3" thick	Cost-effective protection when applied with adequate thickness. Hand-application generally requires greater thickness than blown straw. The thickness of straw may be reduced by half when used in conjunction with seeding. In windy areas straw must be held in place by crimping, using a tackifier, or covering with netting. Blown straw always has to be held in place with a tackifier as even light winds will blow it away. Straw, however, has several deficiencies that should be considered when selecting mulch materials. It often introduces and/or encourages the propagation of weed species and it has no significant long-term benefits. It should also not be used within the ordinary high water elevation of surface waters (due to flotation).
Hydromulch – Short-Term	WSDOT Standard Specification for Short-Term Mulch	Approximately 1,500–2,000 lbs per acre: Apply per the manufacturer’s recommendations	Applied with a hydromulcher, often combined with seed and fertilizer. Contains a tackifier and requires a typical cure time of 24–48 hours before rain. Soil must be completely and uniformly covered, without shadow areas where soil shows through. These mulches do not hold up to concentrated flows. Under normal conditions, will last 3–6 months.
Hydromulch – Moderate-Term	WSDOT Standard Specification for Moderate-Term Mulch	Approximately 3,000–4,000 lbs per acre: Apply per the manufacturer’s recommendations	Applied with a hydromulcher, often combined with seed and fertilizer. Contains a tackifier and requires a typical cure time of 24–48 hours before rain. Soil must be completely and uniformly covered, without shadow areas where soil shows through. Moderate-Term Mulch needs to be applied in more than one layer with no more than 2,000 pounds per acre in any one layer. These mulches do not hold up to concentrated flows. Under normal circumstances, will last 6–12 months.
Hydromulch – Long-Term	WSDOT Standard Specification for Long-Term Mulch	Approximately 3,000–4,000 lbs per acre: Apply per the manufacturer’s recommendations	Applied with a hydromulcher, often combined with seed and fertilizer. May only require 2–4 hours of cure time. Soil must be completely and uniformly covered, without shadow areas where soil shows through. Long-Term Mulch needs to be applied in more than one layer with no more than 2,000 pounds per acre in any one layer. These mulches do not hold up to concentrated flows. Under normal circumstances, will last 12–18 months.
Compost	WSDOT Standard Specification for Coarse Compost	2" thick minimum	More effective control can be obtained by increasing thickness to 3 inches. Excellent mulch for protecting final grades until landscaping because it can be directly seeded or tilled into soil as an amendment. Compost used for mulch has a coarser size gradation than compost used for BMP C-125 or the postconstruction soil quality and depth BMP see Volume V, Chapter 6. It is more stable and practical to use in wet areas and during rainy weather conditions. Do not use near wetlands or near phosphorous impaired water bodies.

Table 3.8 (continued). Mulch Standards and Guidelines.			
Mulch Material	Quality Standards	Application Rates	Remarks
Chipped Site Vegetation	Average size should be several inches. Gradations from fines to 6 inches in length for texture, variation, and interlocking properties.	2" thick minimum	This is a cost-effective way to dispose of debris from clearing and grubbing, and it eliminates the problems associated with burning. Generally, it should not be used on slopes above approximately 10 percent because of its tendency to be transported by runoff. It is not recommended within 200 feet of surface waters. If seeding is expected shortly after mulch, the decomposition of the chipped vegetation may tie up nutrients important to grass establishment.
Wood-based Mulch	No visible water or dust during handling. Must be purchased from a supplier with a Solid Waste Handling Permit or one exempt from solid waste regulations.	2" thick minimum; approximately 100 tons per acre (approximately 800 lbs per cubic yard)	This material is often called "hog fuel" or "hogged fuel." The use of mulch ultimately improves the organic matter in the soil. Special caution is advised regarding the source and composition of wood-based mulches. Its preparation typically does not provide any weed seed control, so evidence of residual vegetation in its composition or known inclusion of weed plants or seeds should be monitored and prevented (or minimized). Note: Wood based mulches may not be used for construction road stabilization where paved surfaces are to be constructed.
Wood Strand Mulch or Wood Straw	A blend of loose, long, thin wood pieces derived from native conifer or deciduous trees with high length-to-width ratio.	2" thick minimum; approximately 100 tons per acre (approximately 800 lbs per cubic yard)	Cost-effective protection when applied with adequate thickness. A minimum of 95 percent of the wood strand shall have lengths between 2 and 10 inches, with a width and thickness between one-sixteenth and three-eighths inch. The mulch shall not contain resin, tannin, or other compounds in quantities that would be detrimental to plant life. Sawdust or wood shavings shall not be used as mulch. (WSDOT Standard Specification 9-14.4(4)). Note: Wood based mulches may not be used for construction road stabilization where paved surfaces are to be constructed.

Coarse Compost

- Mulch may be applied at any time of the year and must be refreshed periodically
- Minimum Percent passing 3-inch sieve openings 100 percent
- Minimum Percent passing 1-inch sieve openings 90 percent
- Minimum Percent passing 0.75-inch sieve openings 70 percent
- Minimum Percent passing 0.25-inch sieve openings 40 percent.
- Mulch used within the ordinary high-water mark of surface waters must be selected to minimize potential flotation of organic matter. Composted organic materials have higher specific gravities (densities) than straw, wood, or chipped material.

Maintenance Standards

- The thickness of the cover must be maintained.
- Any areas that experience erosion shall be remulched and/or protected with a net or blanket. If the erosion problem is drainage related, then the problem shall be fixed and the eroded area remulched.

BMP C122: Nets and Blankets

Purpose

Erosion control nets and blankets are intended to prevent erosion and hold seed and mulch in place on steep slopes and in channels so that vegetation can become well established. In addition, some nets and blankets can be used to permanently reinforce turf to protect drainage ways during high flows. Nets (commonly called matting) are strands of material woven into an open, but high-tensile strength net (for example, coconut fiber matting). Blankets are strands of material that are not tightly woven, but instead form a layer of interlocking fibers, typically held together by a biodegradable or photodegradable netting (for example, excelsior or straw blankets). They generally have lower tensile strength than nets, but cover the ground more completely. Coir (coconut fiber) fabric comes as both nets and blankets.

Conditions of Use

Erosion control nets and blankets shall be used:

- To aid permanent vegetated stabilization of slopes 2H:1V or greater and with more than 10 feet of vertical relief.
- For drainage ditches and swales, unless rock lined. The application of appropriate netting or blanket to drainage ditches and swales can protect bare soil from channelized runoff while vegetation is established. Nets and blankets also can capture a great deal of sediment due to their open, porous structure. Nets and blankets can be used to permanently stabilize channels and may provide a cost-effective, environmentally preferable alternative to riprap. One hundred percent synthetic blankets manufactured for use in ditches may be easily reused as temporary ditch liners.

Disadvantages of blankets include:

- Surface preparation is required.
- On slopes steeper than 2.5H:1V, blanket installers may need to be roped and harnessed for safety.

Advantages of blankets include:

- Installation without mobilizing special equipment.
- Installation by anyone with minimal training.
- Installation in stages or phases as the project progresses.
- Installers can hand place seed and fertilizer as they progress down the slope.

- Installation in any weather.
- There are numerous types of blankets that can be designed with various parameters in mind. Those parameters include: fiber blend, mesh strength, longevity, biodegradability, cost, and availability.

Design and Installation Specifications

- See Figures 3.3 and 3.4 for typical orientation and installation of blankets used in channels and as slope protection. Note: These are typical only; all blankets must be installed per manufacturer's installation instructions.
- Installation is critical to the effectiveness of these products. If good ground contact is not achieved, runoff can concentrate under the product, resulting in significant erosion.
- Installation of blankets on slopes:
 - Complete final grade and track walk up and down the slope.
 - Install hydromulch with seed and fertilizer.
 - Dig a small trench, approximately 12 inches wide by 6 inches deep along the top of the slope.
 - Install the leading edge of the blanket into the small trench and staple approximately every 18 inches. NOTE: Staples are metal, U-shaped, and a minimum of 6 inches long. Longer staples are used in sandy soils. Biodegradable stakes are also available.
 - Roll the blanket slowly down the slope as installer walks backwards. NOTE: The blanket rests against the installer's legs. Staples are installed as the blanket is unrolled. It is critical that the proper staple pattern is used for the blanket being installed. The blanket is not to be allowed to roll down the slope on its own as this stretches the blanket making it impossible to maintain soil contact. In addition, no one is allowed to walk on the blanket after it is in place.
 - If the blanket is not long enough to cover the entire slope length, the trailing edge of the upper blanket must overlap the leading edge of the lower blanket and be stapled. On steeper slopes, this overlap must be installed in a small trench, stapled, and covered with soil.

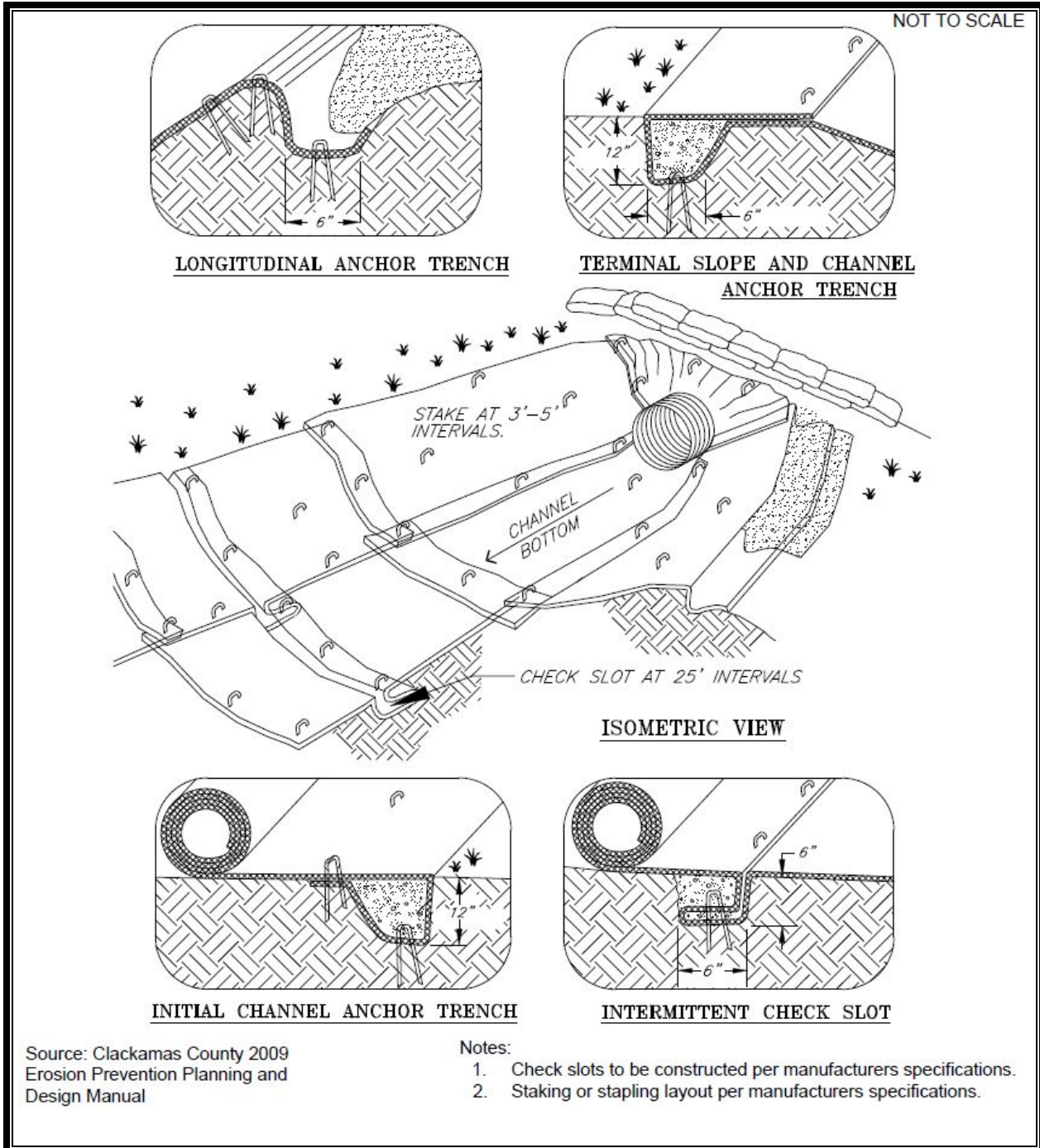

Figure 3.3. Channel Installation.

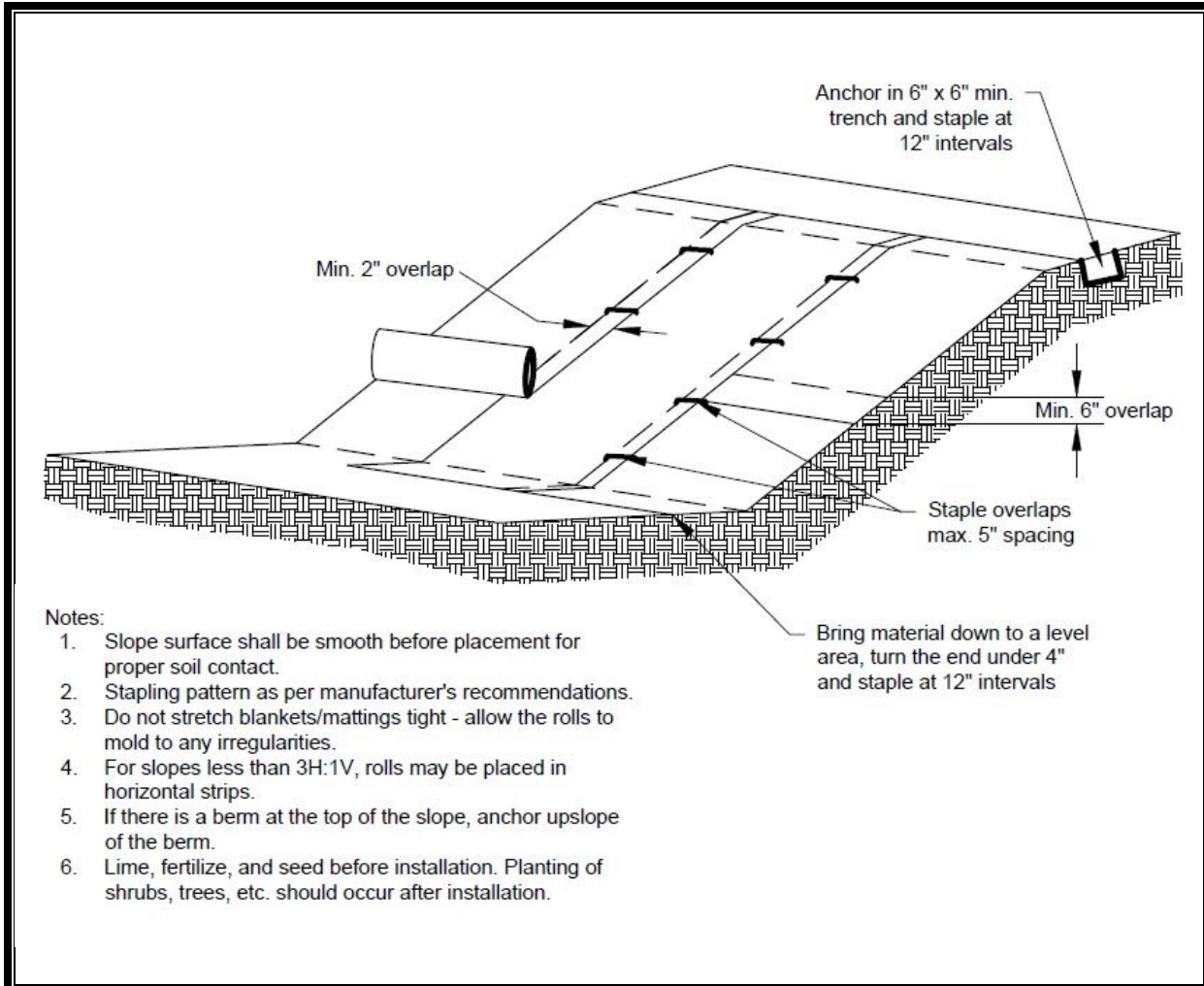

Figure 3.4 Slope Installation.

- With the variety of products available, it is impossible to cover all the details of appropriate use and installation. Therefore, it is critical that the design engineer consult the manufacturer's information and that a site visit takes place to ensure that the product specified is appropriate. Information is also available at WSDOT's web site: <[www.wsdot.wa.gov/ ErosionTrainingManual.pdf](http://www.wsdot.wa.gov/ErosionTrainingManual.pdf)>.
- Use jute matting in conjunction with mulch (BMP C121). Excelsior, woven straw blankets and coir (coconut fiber) blankets may be installed without mulch. There are many other types of erosion control nets and blankets on the market that may be appropriate in certain circumstances.
- In general, most nets (e.g., jute matting) require mulch to prevent erosion because they have a fairly open structure. Blankets typically do not require mulch because they usually provide complete protection of the surface.

- Extremely steep, unstable, wet, or rocky slopes are often appropriate candidates for use of synthetic blankets, as are riverbanks, beaches and other high-energy environments. If synthetic blankets are used, the soil should be hydromulched first.
- One hundred percent biodegradable blankets are available for use in sensitive areas. These organic blankets are usually held together with a paper or fiber mesh and stitching, which may last up to a year.
- Most netting used with blankets is photodegradable, meaning they break down under sunlight (not UV stabilized). However, this process can take months or years even under bright sun. Once vegetation is established, sunlight does not reach the mesh. It is not uncommon to find non-degraded netting still in place several years after installation. This can be a problem if maintenance requires the use of mowers or ditch cleaning equipment. In addition, birds and small animals can become trapped in the netting.

Maintenance Standards

- Maintain good contact with the ground. Erosion must not occur beneath the net or blanket.
- Repair and staple any areas of the net or blanket that are damaged or not in close contact with the ground.
- Fix and protect eroded areas if erosion occurs due to poorly controlled drainage.

BMP C123: Plastic Covering

Purpose

Plastic covering provides immediate, short-term erosion protection to slopes and disturbed areas.

Conditions of Use

- Plastic is particularly useful for protecting cut and fill slopes and stockpiles. Note: The relatively rapid breakdown of most polyethylene sheeting makes it unsuitable for long-term applications.
 - Plastic covering may be used on disturbed areas that require cover measures for less than 30 days, except as stated below. Due to rapid runoff caused by plastic covering, this method shall not be used upslope of areas that might be adversely impacted by concentrated runoff. Such areas include steep and/or unstable slopes.
- Plastic sheeting may result in increased runoff volumes and velocities, requiring additional on-site measures to counteract the increases. Creating a trough with wattles or other material can convey clean water away from these areas.
- To prevent undercutting, trench and backfill rolled plastic covering products.
- Whenever plastic is used to protect slopes install water collection measures at the base of the slope. These measures include plastic-covered berms, channels, and pipes used to convey clean rainwater away from bare soil and disturbed areas. Do not mix clean runoff from a plastic covered slope with dirty runoff from a project.
- Other uses for plastic include:
 - Temporary ditch liner
 - Pond liner in temporary sediment pond
 - Liner for bermed temporary fuel storage area if plastic is not reactive to the type of fuel being stored
 - Emergency slope protection during heavy rains
 - Temporary drainpipe (“elephant trunk”) used to direct water

Design and Installation Specifications

- Plastic slope cover must be installed as follows:
 - Run plastic up and down slope, not across slope, unless the slope length is less than 10 feet, and then it may be installed perpendicular to a slope.

- Minimum of 8-inch overlap at seams.
- On long or wide slopes, or slopes subject to wind, tape all seams.
- Place plastic into a small (12-inch wide by 6-inch deep) slot trench at the top of the slope and backfill with soil to keep water from flowing underneath
- Place sand filled burlap or geotextile bags every 3 to 6 feet along seams and tie them together with twine to hold them in place
- Inspect plastic for rips, tears, and open seams regularly and repair immediately. This prevents high velocity runoff from contacting bare soil, which causes extreme erosion.
- Sandbags may be lowered into place tied to ropes. However, all sandbags must be staked in place.
- Plastic sheeting shall have a minimum thickness of 6 mil.
- If erosion at the toe of a slope is likely, a gravel berm, riprap, or other suitable protection shall be installed at the toe of the slope to reduce the velocity of runoff.

Maintenance Standards

- Torn sheets must be replaced and open seams repaired.
- Completely remove and replace the plastic if it begins to deteriorate due to ultraviolet radiation.
- Completely remove plastic when no longer needed.
- Dispose of old tires used to weight down plastic sheeting appropriately.

Approved as Equivalent

Ecology has approved specific products as able to meet the requirements of BMP C123. However, the products did not pass through the TAPE process. The list of products is available on Ecology's web site at

<www.ecy.wa.gov/programs/wq/stormwater/newtech/equivalent.html>.

If a project wishes to use any of the “approved as equivalent” BMPs in the City of Tumwater, the project owner or representative must obtain approval for use of the BMP from the city on a case-by-case basis (i.e., for each project or site) before use.

BMP C124: Sodding

Purpose

The purpose of sodding is to establish permanent turf for immediate erosion protection and to stabilize drainage ways where concentrated overland flow will occur.

Conditions of Use

Sodding may be used in the following areas:

- Disturbed areas that require short-term or long-term cover.
- Disturbed areas that require immediate vegetative cover.
- All waterways that require vegetative lining. Waterways may also be seeded rather than sodded, and protected with a net or blanket.

Design and Installation Specifications

Sod shall be free of weeds, of uniform thickness (approximately 1 inch thick), and shall have a dense root mat for mechanical strength.

The following steps are recommended for sod installation:

- Shape and smooth the surface to final grade in accordance with the approved grading plan. The swale needs to be overexcavated 4 to 6 inches below design elevation to allow room for placing soil amendment and sod.
- Amend 4 inches (minimum) of compost into the top 8 inches of the soil if the organic content of the soil is less than 10 percent or the permeability is less than 0.6 inch per hour. See <https://ecology.wa.gov/Waste-Toxics/Reducing-recycling-waste/Organic-materials/Managing-organics-compost> for further information.
- Fertilize according to the supplier's recommendations.
- Work lime and fertilizer 1 to 2 inches into the soil, and smooth the surface.
- Lay strips of sod beginning at the lowest area to be sodded and perpendicular to the direction of water flow. Wedge strips securely into place. Square the ends of each strip to provide for a close, tight fit. Stagger joints at least 12 inches. Staple on slopes steeper than 3H:1V. Staple the upstream edge of each sod strip.
- Roll the sodded area and irrigate.
- When sodding is carried out in alternating strips or other patterns, seed the areas between the sod immediately after sodding.

Maintenance Standards

If the grass is unhealthy, the cause shall be determined and appropriate action taken to re-establish a healthy groundcover. If it is impossible to establish a healthy groundcover due to frequent saturation, instability, or some other cause, the sod shall be removed, the area seeded with an appropriate mix, and protected with a net or blanket.

BMP C125: Topsoiling/Composting

Purpose

Topsoiling and composting provide a suitable growth medium for final site stabilization with vegetation. While not a permanent cover practice in itself, topsoiling and composting are integral components of providing permanent cover in areas where there is an unsuitable soil surface for plant growth. Use this BMP in conjunction with other BMPs such as seeding, mulching, or sodding. Note that this BMP is functionally the same as the postconstruction soil quality and depth BMP (see Volume V, Chapter 6), which is required for all disturbed areas that will be developed as lawn or landscaped areas at the completed project site.

Native soils and disturbed soils that have been organically amended not only retain much more stormwater, but they also serve as effective biofilters for urban pollutants and, by supporting more vigorous plant growth, reduce the water, fertilizer and pesticides needed to support installed landscapes. Topsoil does not include any subsoils but only the material from the top several inches including organic debris.

Conditions of Use

- Permanent landscaped areas shall contain healthy topsoil that reduces the need for fertilizers, improves overall topsoil quality, provides for better vegetal health and vitality, improves hydrologic characteristics, and reduces the need for irrigation.
- Leave native soils and the duff layer undisturbed to the maximum extent practicable. Stripping of existing, properly functioning soil system and vegetation for the purpose of topsoiling during construction **is not acceptable**. Preserve existing soil systems in undisturbed and uncompacted condition if functioning properly.
- Areas that already have good topsoil, such as undisturbed areas, do not require soil amendments.
- Restore, to the maximum extent practicable, native soils disturbed during clearing and grading to a condition equal to or better than the original site condition's moisture-holding capacity. Use on-site native soil, incorporate amendments into on-site soil, or importing blended topsoil to meet this requirement.
- Topsoiling is a required procedure when establishing vegetation on shallow soils, and soils of critically low pH (high acid) levels.
- Beware of where the topsoil comes from, and what vegetation was on site before disturbance, invasive plant seeds may be included and could cause problems for establishing native plants, landscaped areas, or grasses.

- Topsoil from the site shall contain mycorrhizal bacteria that are necessary for healthy root growth and nutrient transfer. These native mycorrhiza are acclimated to the site and will provide optimum conditions for establishing grasses. Commercially available mycorrhiza products shall be used when bringing in off-site topsoil.

Design and Installation Specifications

The following requirements must be met for disturbed areas requiring disruption and topsoiling, which will be developed as lawn or landscaped areas at project completion:

- Maximize the depth of the topsoil wherever possible to provide the maximum possible infiltration capacity and beneficial growth medium. Topsoil shall have:
 - A minimum organic content of 10 percent dry weight in planting beds, and 5 percent organic matter content in turf areas.
 - A pH between 6.0 and 8.0 or matching the pH of the undisturbed soil.
 - A minimum depth of 8 inches. Incorporate organic amendments to a minimum 8-inch depth except where tree roots or other natural features limit the depth of incorporation.
 - Scarify subsoils below the topsoil layer at least 4 inches with some incorporation of the upper material to avoid stratified layers, unless infeasible. Ripping or restructuring the subgrade may also provide additional benefits regarding the overall infiltration and interflow dynamics of the soil system. If blended topsoil is imported, then fines shall be limited to 25 percent passing through a U.S. #200 sieve.
 - Mulch planting beds with 2 inches of organic material.
- Accomplish the required organic content, depth, and pH by returning native topsoil to the site, importing topsoil of sufficient organic content, and/or incorporating organic amendments.
 - When using the option of incorporating amendments to meet the organic content requirement, use compost that meets the composted material specification for bioretention (see Volume V, Chapter 9), with the exception that the compost may have up to 35 percent biosolids or manure.
 - Sections 3 through 7 of the document entitled Guidelines and Resources for Implementing Soil Quality and Depth BMP T5.13 in Ecology's Stormwater Management Manual for Western Washington provide useful guidance for implementing whichever option is chosen. The document includes guidance for preapproved default strategies and guidance for custom strategies. As of this printing the document can be found at:
<https://ecology.wa.gov/DOE/files/45/4569b90a-217a-40d2-a997-49adb8db5d86.pdf>

- The final composition and construction of the soil system will result in a natural selection or favoring of certain plant species over time. For example, incorporation of topsoil may favor grasses, while layering with mildly acidic, high-carbon amendments may favor more woody vegetation.
- Allow sufficient time in scheduling for topsoil spreading prior to seeding, sodding, or planting.
- Take care when applying top soil to subsoils with contrasting textures. Sandy topsoil over clayey subsoil is a particularly poor combination, as water creeps along the junction between the soil layers and causes the topsoil to slough. If topsoil and subsoil are not properly bonded, water will not infiltrate the soil profile evenly and it will be difficult to establish vegetation. The best method to prevent a lack of bonding is to work the topsoil into the layer below for a depth of at least 4 inches below the topsoil layer.
- Field exploration of the site shall be made to determine if there is surface soil of sufficient quantity and quality to justify stripping. Topsoil shall be friable and loamy (loam, sandy loam, silt loam, sandy clay loam, and clay loam). Avoid areas of natural groundwater recharge.
- Stripping shall be confined to the immediate construction area. A 4-inch to 6-inch stripping depth is common, but depth may vary depending on the particular soil. All surface runoff control structures shall be in place prior to stripping.
- Do not place topsoil while in a frozen or muddy condition, when the subgrade is excessively wet, or when conditions exist that may otherwise be detrimental to proper grading or proposed sodding or seeding.
- In any areas requiring grading, remove and stockpile the duff layer and topsoil on site in a designated, controlled area, not adjacent to public resources and critical areas. Stockpiled topsoil is to be reapplied to other portions of the site where feasible.
- Locate the topsoil stockpile so that it meets specifications and does not interfere with work on the site. It may be possible to locate more than one pile in proximity to areas where topsoil will be used.

Stockpiling of topsoil shall occur in the following manner:

- Side slopes of the stockpile shall not exceed 2H:1V.
- Between October 1 and April 30:
 - An interceptor dike with gravel outlet and silt fence shall surround all topsoil.

- Within 2 days, complete erosion control seeding, or covering stockpiles with clear plastic, or other mulching materials.
- Between May 1 and September 30:
 - An interceptor dike with gravel outlet and silt fence shall surround all topsoil if the stockpile will remain in place for a longer period of time than active construction grading.
 - Within 7 days, complete erosion control seeding, or covering stockpiles with clear plastic, or other mulching materials.
- When native topsoil is to be stockpiled and reused, the following shall apply to ensure that the mycorrhizal bacterial, earthworms, and other beneficial organisms will not be destroyed:
 - Re-install topsoil within 4 to 6 weeks
 - Do not allow the saturation of topsoil with water
 - Do not use plastic covering.

Maintenance Standards

- Inspect stockpiles regularly, especially after large storm events. Stabilize any areas that have eroded.
- Establish soil quality and depth toward the end of construction and once established, protect from compaction, such as from large machinery use, and from erosion.
- Plant and mulch soil after installation.
- Leave plant debris or its equivalent on the soil surface to replenish organic matter.
- Reduce and adjust, where possible, the use of irrigation, fertilizers, herbicides and pesticides, rather than continuing to implement formerly established practices.

BMP C126: Polyacrylamide for Soil Erosion Protection

Purpose

Polyacrylamide (PAM) is used on construction sites to prevent soil erosion.

Applying PAM to bare soil in advance of a rain event significantly reduces erosion and controls sediment in two ways. First, PAM increases the soil's available pore volume, thus increasing infiltration through flocculation and reducing the quantity of stormwater runoff. Second, it increases flocculation of suspended particles and aids in their deposition, thus reducing stormwater runoff turbidity and improving water quality.

Conditions of Use

PAM shall not be directly applied to water or allowed to enter a water body. Some PAMs are more toxic and carcinogenic than others. Only the highest drinking water grade PAM, certified for compliance with ANSI/NSF Standard 60 for drinking water treatment, will be used for soil applications.

The specific PAM copolymer formulation must be anionic. **Cationic PAM shall not be used in any application because of known aquatic toxicity problems.** Recent media attention and high interest in PAM has resulted in some entrepreneurial exploitation of the term "polymer." All PAM are polymers, but not all polymers are PAM, and not all PAM products comply with ANSI/NSF Standard 60. PAM use shall be reviewed and approved by the city. The city allows for the use of Washington State Department of Transportation (WSDOT) PAM products that are listed and approved per the WSDOT Qualified Products List, <http://www.wsdot.wa.gov/biz/mats/QPL/QPL_Search.cfm>, in accordance with WSDOT Standard Specification 9-14.5(1); however, use of PAM products shall still be preapproved by the city.

In areas that drain to a sediment pond, PAM can be applied to bare soil under the following conditions:

- During rough grading operations.
- In staging areas.
- Balanced cut and fill earthwork.
- Haul roads prior to placement of crushed rock surfacing.
- Compacted soil roadbase.
- Stockpiles.
- After final grade and before paving or final seeding and planting.
- Pit sites.

- Sites having a winter shut down. In the case of winter shut down, or where soil will remain unworked for several months, PAM should be used together with mulch.

Design and Installation Specifications

PAM may be applied with water in dissolved form. The preferred application method is the dissolved form.

PAM is to be applied at a maximum rate of two-thirds of a pound of PAM per 1,000 gallons water (80 milligrams per liter [mg/L]) per 1 acre of bare soil. Table 3.9 can be used to determine the PAM and water application rate for a disturbed soil area. Higher concentrations of PAM **do not** provide any additional effectiveness.

Disturbed Area (acres)	PAM (pounds)	Water (gallons)
0.50	0.33	500
1.00	0.66	1,000
1.50	1.00	1,500
2.00	1.32	2,000
2.50	1.65	2,500
3.00	2.00	3,000
3.50	2.33	3,500
4.00	2.65	4,000
4.50	3.00	4,500
5.00	3.33	5,000

The Preferred Method

- Pre-measure the area where PAM is to be applied and calculate the amount of product and water necessary to provide coverage at the specified application rate (two-thirds of a pound of PAM/1,000 gallons/acre).
- PAM has high solubility in water, but dissolves very slowly. Dissolve pre-measured dry granular PAM with a known quantity of clean water in a bucket several hours or overnight. Mechanical mixing will help dissolve the PAM. Always add PAM to water—not water to PAM.
- Pre-fill the water truck about one-eighth full with water. The water does not have to be potable, but it must have relatively low turbidity—in the range of 20 NTU or less.
- Add PAM-and-water mixture to the truck.
- Completely fill the water truck to specified volume.
- Spray PAM-and-water mixture onto dry soil until the soil surface is uniformly and completely wetted.

An Alternate Method

PAM may also be applied as a powder at the rate of 5 pounds per acre. This must be applied on a day that is dry. For areas of less than 5 acres, a hand-held “organ grinder” fertilizer spreader set to the smallest setting will work. Tractor-mounted spreaders will work for larger areas.

The following shall be used for application of powdered PAM:

- Powdered PAM shall be used in conjunction with other BMPs and not in place of other BMPs.
- Do not use PAM on a slope that flows directly into a stream or wetland. The stormwater runoff shall pass through a sediment control BMP prior to discharging to surface waters.
- Do not add PAM to water discharging from site.
- When the total drainage area is greater than or equal to 5 acres, PAM treated areas shall drain to a sediment pond.
- Areas less than 5 acres shall drain to sediment control BMPs, such as a minimum of three check dams per acre. The total number of check dams used shall be maximized to achieve the greatest amount of settlement of sediment prior to discharging from the site. Each check dam shall be spaced evenly in the drainage channel through which stormwater flows are discharged off site.
- On all sites, the use of silt fence shall be maximized to limit the discharges of sediment from the site.
- All areas not being actively worked shall be covered and protected from rainfall. PAM shall not be the only cover BMP used.
- PAM can be applied to wet soil, but dry soil is preferred due to less sediment loss.
- PAM will work when applied to saturated soil but is not as effective as applications to dry or damp soil.
- Keep the granular PAM supply out of the sun. Granular PAM loses its effectiveness in 3 months after exposure to sunlight and air.
- Proper application and re-application plans are necessary to ensure total effectiveness of PAM usage.
- PAM, combined with water, is very slippery and can be a safety hazard. Care must be taken to prevent spills of PAM powder onto paved surfaces. During an application of PAM, prevent over-spray from reaching pavement as pavement

will become slippery. If PAM powder gets on skin or clothing, wipe it off with a rough towel rather than washing with water-this only makes cleanup messier and take longer.

- PAM designated for these uses should be “water soluble” or “linear” or “non-crosslinked.” Cross-linked or water absorbent PAM, polymerized in highly acidic (pH less than 2) conditions, are used to maintain soil moisture content.
- The PAM anionic charge density may vary from 2 to 30 percent; a value of 18 percent is typical. Studies conducted by the USDA Agricultural Research Service demonstrated that soil stabilization was optimized by using very high molecular weight (12 to 15 mg/mole), highly anionic (more than 20 percent hydrolysis) PAM.
- PAM tackifiers are available and being used in place of guar and alpha plantago. Typically, PAM tackifiers should be used at a rate of no more than 0.5 to 1 pound per 1,000 gallons of water in a hydromulch machine. Some tackifier product instructions say to use at a rate of 3 to 5 pounds per acre, which can be too much. In addition, pump problems can occur at higher rates due to increased viscosity.

Maintenance Standards

- PAM may be reapplied on actively worked areas after a 48-hour period.
- Reapplication is not required unless PAM treated soil is disturbed or unless turbidity levels show the need for an additional application. If PAM treated soil is left undisturbed a reapplication may be necessary after 2 months. More PAM applications may be required for steep slopes, silty and clayey soils (USDA Classification Type “C” and “D” soils), long grades, and high precipitation areas. When PAM is applied first to bare soil and then covered with straw, a reapplication may not be necessary for several months.
- Loss of sediment and PAM may be a basis for penalties per RCW 90.48.080.

BMP C130: Surface Roughening

Purpose

Surface roughening aids in the establishment of vegetative cover, reduces runoff velocity, increases infiltration, and provides for sediment trapping through the provision of a rough soil surface. Horizontal depressions are created by operating a tiller or other suitable equipment on the contour or by leaving slopes in a roughened condition by not fine grading them.

Use this BMP in conjunction with other BMPs such as seeding, mulching, or sodding.

Conditions for Use

- All slopes steeper than 3H:1V and greater than 5 vertical feet require surface roughening to a depth of 2 to 4 inches prior to seeding.
- Areas that will not be stabilized immediately may be roughened to reduce runoff velocity until seeding takes place.
- Slopes with a stable rock face do not require roughening.
- Slopes where mowing is planned should not be excessively roughened.

Design and Installation Specifications

There are different methods for achieving a roughened soil surface on a slope, and the selection of an appropriate method depends upon the type of slope. Roughening methods include stair-step grading, grooving, contour furrows, and tracking. See Figure 3.5 for tracking and contour furrows. Factors to be considered in choosing a method are slope steepness, mowing requirements, and whether the slope is formed by cutting or filling.

- Disturbed areas that will not require mowing may be stair-step graded, grooved, or left rough after filling.
- Stair-step grading is particularly appropriate in soils containing large amounts of soft rock. Each “step” catches material that sloughs from above, and provides a level site where vegetation can become established. Stairs must be wide enough to work with standard earth moving equipment. Stair steps must be on contour or gullies will form on the slope.
- Areas that will be mowed (these areas should have slopes less steep than 3H:1V) may have small furrows left by disking, harrowing, raking, or seed-planting machinery operated on the contour.

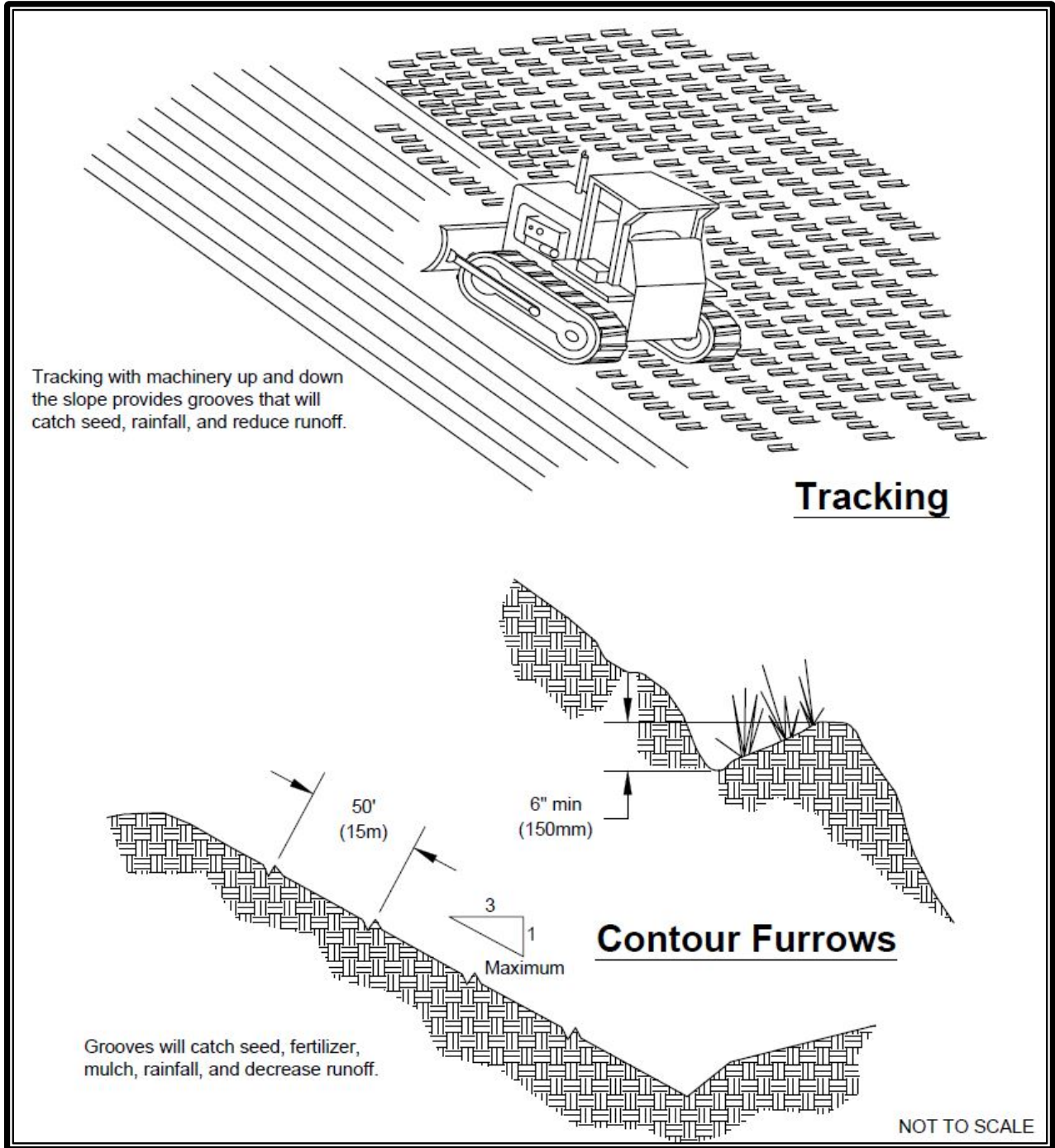

Figure 3.5. Surface Roughening by Tracking and Contour Furrows.

- Graded areas with slopes steeper than 3H:1V but less than 2H:1V shall be roughened before seeding. This can be accomplished in a variety of ways, including “track walking,” or driving a crawler tractor up and down the slope, leaving a pattern of cleat imprints parallel to slope contours.
- Tracking is done by operating equipment up and down the slope to leave horizontal depressions in the soil.

Maintenance Standards

- Areas that are graded in this manner should be seeded as quickly as possible.
- Regular inspections should be made of the area. If rills appear, they should be regraded and reseeded immediately.

BMP C131: Gradient Terraces

Purpose

Gradient terraces reduce erosion damage by intercepting surface runoff and conducting it to a stable outlet at a nonerosive velocity.

Conditions of Use

- Gradient terraces normally are limited to denuded land having a water erosion problem. They should not be constructed on deep sands or on soils that are too stony, steep, or shallow to permit practical and economical installation and maintenance. Gradient terraces may be used only where suitable outlets are or will be made available. See Figure 3.6 for gradient terraces.

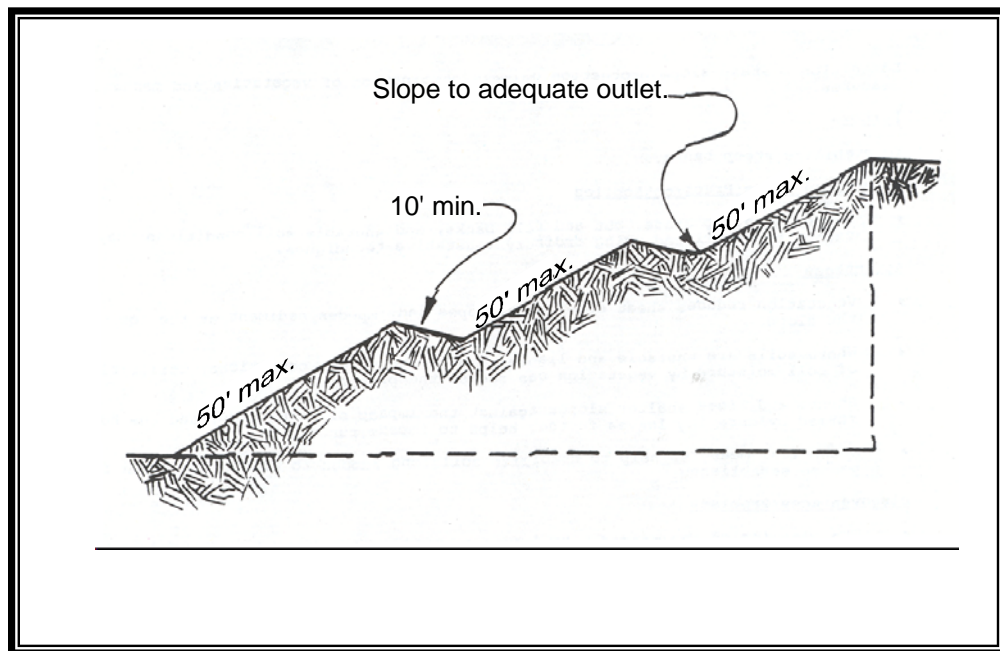

Figure 3.6. Gradient Terraces.

Design and Installation Specifications

- The maximum spacing of gradient terraces shall be determined using the following method:

$$VI = (0.8)s + y$$

Where: VI = vertical interval in feet
 s = land rise per 100 feet, expressed in feet
 y = a soil and cover variable with values from 1.0 to 4.0

Values of “y” are influenced by soil erodibility and cover practices. The lower values are applicable to erodible soils where little to no residue is left on the

surface. The higher value is applicable only to erosion-resistant soils where a large amount of residue (1.5 tons of straw/acre equivalent) is on the surface.

- The minimum constructed cross-section shall meet the design dimensions.
- The top of the constructed ridge shall not be lower at any point than the design elevation plus the specified overfill for settlement. The opening at the outlet end of the terrace shall have a cross-section equal to that specified for the terrace channel.
- Channel grades may be either uniform or variable with a maximum grade of 0.6 foot per 100-foot length (0.6 percent). For short distances, terrace grades may be increased to improve alignment. The channel velocity shall not exceed that which is nonerosive for the soil type.
- All gradient terraces must have adequate outlets. Such an outlet may be a grassed waterway, vegetated area, or tile outlet. In all cases the outlet must convey runoff from the terrace or terrace system to a point where the outflow will not cause damage. Vegetative cover should be used in the outlet channel.
- The design elevation of the water surface of the terrace should not be lower than the design elevation of the water surface in the outlet at their junction, when both are operating at design flow.
- Vertical spacing determined by the above methods may be increased as much as 0.5 foot or 10 percent, whichever is greater, to provide better alignment or location, to avoid obstacles, to adjust for equipment size, or to reach a satisfactory outlet.
 - The drainage area above the top shall not exceed the area that would be drained by a terrace with normal spacing.
- The terrace shall have enough capacity to handle the peak runoff expected from a 2-year, 24-hour design storm without overtopping.
- The terrace cross-section should be proportioned to fit the land slope. The ridge height shall include a reasonable settlement factor. The ridge must have a minimum top width of 3 feet at the design height. The minimum cross-sectional area of the terrace channel shall be 8 square feet for land slopes of 5 percent or less, 7 square feet for slopes from 5 to 8 percent, and 6 square feet for slopes steeper than 8 percent. The terrace can be constructed wide enough to be maintained using a small vehicle.

Maintenance Standards

- Maintenance shall be performed as needed. Terraces shall be inspected during the course of regular erosion control inspections.

BMP C140: Dust Control

Purpose

Dust control prevents wind transport of dust from disturbed soil surfaces onto roadways, drainage ways, and surface waters.

Conditions of Use

For use in areas (including roadways) subject to surface and air movement of dust where on-site and off-site impacts on roadways, drainage ways, or surface waters are likely.

Design and Installation Specifications

- Vegetate or mulch areas that will not receive vehicle traffic. In areas where planting, mulching, or paving is impractical, apply gravel or landscaping rock.
- Limit dust generation by clearing only those areas where immediate activity will take place, leaving the remaining area(s) in the original condition. Maintain the original ground cover as long as practical.
- Construct natural or artificial windbreaks or windscreens. These may be designed as enclosures for small dust sources.
- Sprinkle the site with water until surface is wet. Repeat as needed. To prevent carryout of mud onto street, refer to Stabilized Construction Entrance (BMP C105).
- Irrigation water can be used for dust control. Irrigation systems should be installed as a first step on sites where dust control is a concern.
- Spray exposed soil areas with a dust palliative, following the manufacturer's instructions and cautions regarding handling and application. Oil based products are prohibited from use as a dust suppressant. The city may approve other dust palliatives such as calcium chloride or PAM.
- PAM (BMP C126) added to water at a rate of 0.5 pounds per 1,000 gallons of water per acre and applied from a water truck is more effective than water alone. This is due to increased infiltration of water into the soil and reduced evaporation. In addition, small soil particles are bonded together and are not as easily transported by wind. Adding PAM may actually reduce the quantity of water needed for dust control. Use of PAM could be a cost-effective dust control method.

Techniques that can be used for unpaved roads and lots include:

- Lower speed limits. High vehicle speed increases the amount of dust stirred up from unpaved roads and lots.
- Upgrade the road surface strength by improving particle size, shape, and mineral types that make up the surface and base materials.
- Add surface gravel to reduce the source of dust emission. Limit the amount of fine particles (those smaller than .075 millimeter [mm]) to 10 to 20 percent.
- Use geotextile fabrics to increase the strength of new roads or roads undergoing reconstruction.
- Encourage the use of alternate, paved routes, if available.
- Restrict use of paved roadways by tracked vehicles and heavy trucks to prevent damage to road surface and base.
- Apply chemical dust suppressants using the admix method, blending the product with the top few inches of surface material. Suppressants may also be applied as surface treatments.
- Pave unpaved permanent roads and other trafficked areas.
- Use vacuum street sweepers.
- Remove mud and other dirt promptly so it does not dry and then turn into dust.
- Limit dust-causing work on windy days.
- Contact your Puget Sound Clean Air Agency <www.pscleanair.org> for guidance and training on other dust control measures. Compliance with Puget Sound Clean Air Agency guidance and BMPs constitutes compliance with this BMP.

Maintenance Standards

Respray area as necessary to keep dust to a minimum.

BMP C150: Materials on Hand

Purpose

Keep quantities of erosion prevention and sediment control materials on the project site at all times to be used for regular maintenance and emergency situations such as unexpected heavy summer rains. Having these materials on site reduces the time needed to implement BMPs when inspections indicate that existing BMPs are not meeting the Construction SWPPP requirements. In addition, contractors can save money by buying some materials in bulk and storing them at their office or yard.

Conditions of Use

- Construction projects of any size or type can benefit from having materials on hand. A small commercial development project could have a roll of plastic and some gravel available for immediate protection of bare soil and temporary berm construction. A large earthwork project, such as highway construction, might have several tons of straw, several rolls of plastic, flexible pipe, sandbags, geotextile fabric, and steel “T” posts.
- Materials are stockpiled and readily available before any site clearing, grubbing, or earthwork begins. A contractor or developer could keep a stockpile of materials that are available for use on several projects.
- If storage space at the project site is at a premium, the contractor could maintain the materials at their office or yard. The office or yard must be less than an hour from the project site.

Design and Installation Specifications

Depending on project type, size, complexity, and length, materials and quantities will vary. A good minimum that will cover numerous situations includes:

Material
Clear Plastic, 6 mil
Drainpipe, 6- or 8-inch diameter
Sandbags, filled
Straw Bales for mulching
Quarry Spalls
Washed Gravel
Geotextile Fabric
Catch Basin Inserts
Steel “T” Posts
Silt fence material
Straw Wattles

Maintenance Standards

- All materials with the exception of the quarry spalls, steel “T” posts, and gravel must be kept covered and out of both sun and rain.
- Restock materials used as needed.

BMP C151: Concrete Handling

Purpose

Concrete work can generate process water and slurry that contain fine particles and high pH, both of which can violate water quality standards in the receiving water. Concrete spillage or concrete discharge to surface waters of the State is prohibited. Use this BMP to minimize and eliminate concrete, concrete process water, and concrete slurry from entering waters of the State.

Conditions of Use

Any time concrete is used, utilize these management practices. Concrete construction projects include, but are not limited to, the following:

- Curbs
- Sidewalks
- Roads
- Bridges
- Foundations
- Floors
- Runways

Design and Installation Specifications

- Ensure that washout of concrete trucks, chutes, pumps, and internals is performed at an approved off-site location or in designated concrete washout areas, in accordance with BMP C154. Do not wash out concrete trucks onto the ground, or into storm drains, open ditches, streets, or streams—it is illegal and a violation of federal, state, and local regulations.
- Return unused concrete remaining in the truck and pump to the originating batch plant for recycling. Do not dump excess concrete on site, except in designated concrete washout areas.
- Wash off hand tools including, but not limited to, screeds, shovels, rakes, floats, and trowels into formed areas only.
- Wash equipment difficult to move, such as concrete pavers in areas that do not directly drain to natural or constructed stormwater conveyances.

- Do not allow washdown from newly placed concrete areas or surfaces, such as concrete aggregate driveways, to drain directly to natural or constructed stormwater conveyances. Collect and dispose of all washdown in accordance with BMP C152.
- Contain washwater and leftover product in a lined container when no formed areas are available. Dispose of contained concrete in a manner that does not violate groundwater or surface water quality standards.
- Always use forms or solid barriers for concrete pours, such as pilings, within 15 feet of surface waters.
- Refer to BMPs C252 and C253 for pH adjustment requirements.
- Refer to the CSWGP for pH monitoring requirements if the project involves one of the following activities:
 - Significant concrete work (greater than 1,000 cubic yards poured concrete or recycled concrete used over the life of a project)
 - The use of engineered soils amended with (but not limited to) portland cement-treated base, cement kiln dust or fly ash.
 - Discharging stormwater to segments of water bodies on the 303(d) list for high pH.

Maintenance Standards

Maintain any concrete washout facilities in accordance with BMP C154.

BMP C152: Sawcutting and Surfacing Pollution Prevention

Purpose

Sawcutting and surfacing operations generate slurry and process water that contains fine particles and high pH (concrete cutting), both of which can violate the water quality standards in the receiving water. Concrete spillage or concrete discharge to surface waters of the State or the city storm drain system is prohibited. Use this BMP to prevent process water and slurry from entering waters of the State.

Conditions of Use

Utilize these management practices anytime sawcutting or surfacing operations take place. Sawcutting and surfacing operations include, but are not limited to, the following:

- Sawing
- Coring
- Grinding
- Roughening
- Hydro-demolition
- Bridge and road surfacing

Design and Installation Specifications

- Vacuum slurry and cuttings during cutting and surfacing operations.
- Slurry and cuttings shall not remain on permanent concrete or asphalt pavement overnight.
- Slurry and cuttings shall not drain to any natural or constructed drainage conveyance including stormwater systems. If the drainage pattern would allow flow from the location of the cutting to a catch basin, the catch basin shall be temporarily blocked.
- Dispose of collected slurry and cuttings in a manner that does not violate groundwater or surface water quality standards, such as at a Vactor decant facility that accepts this material.
- Do not allow process water generated during hydro-demolition, surface roughening or similar operations to drain to any natural or constructed drainage conveyance including stormwater systems. Vacuum up all material and dispose of collected process water in a manner that does not violate groundwater or surface

water quality standards, such as at a Vector decant facility that accepts this material.

- Handle and dispose cleaning waste material and demolition debris in a manner that does not cause contamination of water. Dispose of sweeping material from a pick-up sweeper at an appropriate disposal site.

Maintenance Standards

Continually monitor operations to determine whether slurry, cuttings, or process water could enter waters of the state. If inspections show that a violation of water quality standards could occur, stop operations and immediately implement preventive measures such as berms, barriers, secondary containment, and utilizing vacuum trucks.

BMP C153: Material Delivery, Storage and Containment

Purpose

Prevent, reduce, or eliminate the discharge of pollutants to the stormwater system or watercourses from material delivery and storage. Minimize the storage of hazardous materials on site, store materials in a designated area, and install secondary containment.

Conditions of Use

These procedures are suitable for use at all construction sites with delivery and storage of the following materials:

- Petroleum products such as fuel, oil and grease
- Soil stabilizers and binders (e.g., Polyacrylamide)
- Fertilizers, pesticides and herbicides
- Detergents
- Asphalt and concrete compounds
- Hazardous chemicals such as acids, lime, adhesives, paints, solvents and curing compounds
- Any other material that may be detrimental if released to the environment

Design and Installation Specifications

The following steps should be taken to minimize risk:

- Temporary storage area should be located away from vehicular traffic, near the construction entrance(s), and away from waterways or storm drains.
- Material Safety Data Sheets (MSDS) should be supplied for all materials stored. Chemicals should be kept in their original labeled containers.
- Hazardous material storage on site should be minimized.
- Hazardous materials should be handled as infrequently as possible.
- During the wet weather season (October 1 to April 30), consider storing materials in a covered area.
- Materials should be stored in secondary containments, such as earthen dike, horse trough, or even a children's wading pool for non-reactive materials such as detergents, oil, grease, and paints. Small amounts of material may be secondarily contained in "bus boy" trays or concrete mixing trays.
- Do not store chemicals, drums, or bagged materials directly on the ground. Place these items on a pallet and in secondary containment.

Material Storage Areas and Secondary Containment Practices

- Liquids, petroleum products, and substances listed in 40 CFR Parts 110, 117, or 302 shall be stored in approved containers and drums and shall not be overfilled. Containers and drums shall be stored in temporary secondary containment facilities.
- Temporary secondary containment facilities shall provide for a spill containment volume able to contain 10 percent of the total enclosed container volume of all containers, or 110 percent of the capacity of the largest container within its boundary, whichever is greater.
- Secondary containment facilities shall be impervious to the materials stored therein for a minimum contact time of 72 hours.
- Secondary containment facilities shall be maintained free of accumulated rainwater and spills. In the event of spills or leaks, accumulated rainwater and spills shall be collected and placed into drums. These liquids shall be handled as hazardous waste unless testing determines them to be non-hazardous.
- Provide sufficient separation between stored containers to allow for spill cleanup and emergency response access.
- During the wet weather season (October 1 to April 30), each secondary containment facility shall be covered during non-working days, prior to and during rain events.
- Keep material storage areas clean, organized and equipped with an ample supply of appropriate spill cleanup material (spill kit).
- The spill kit shall include, at a minimum:
 - 1 water resistant nylon bag
 - 3 oil absorbent socks 3 inches by 4 feet
 - 2 oil absorbent socks 3 inches by 10 feet
 - 12 oil absorbent pads 17 inches by 19 inches
 - 1 pair splash resistant goggles
 - 3 pair nitrile gloves
 - 10 disposable bags with ties
 - Instructions

BMP C154: Concrete Washout Area

Purpose

This BMP applies to all projects that use concrete and conduct any form of on-site concrete washout. Prevent the discharge of pollutants to stormwater from concrete waste by conducting washout off site, or performing on-site washout in a designated area to prevent pollutants from entering surface waters or groundwater.

Conditions of Use

Concrete washout area best management practices are implemented on construction projects where:

- Concrete is used as a construction material.
- It is not possible to dispose of all concrete wastewater and washout off site (ready-mix plant, etc.).
- Concrete trucks, pumpers, or other concrete coated equipment are washed on site.

Design and Installation Specifications

Implementation

The following steps are required to reduce stormwater pollution from concrete wastes:

- Perform washout of concrete trucks at an approved off-site location or in designated concrete washout areas only.
- Do not wash out concrete trucks onto the ground, or into storm drains, open ditches, streets, or streams.
- Do not allow excess concrete to be dumped on site, except in designated concrete washout areas.
- Concrete washout areas may be prefabricated concrete washout containers, or self-installed structures (above grade or below grade).
- Prefabricated containers are most resistant to damage and protect against spills and leaks. Companies may offer delivery service and provide regular maintenance and disposal of solid and liquid waste.
- If self-installed concrete washout areas are used, below-grade structures are required.

Education

- Discuss the concrete management techniques described in this BMP with the ready-mix concrete supplier before any deliveries are made.
- Educate employees and subcontractors on the concrete waste management techniques described in this BMP.
- Arrange for contractor's superintendent or CESCL to oversee and enforce concrete waste management procedures.
- A sign should be installed adjacent to each temporary concrete washout facility to inform concrete equipment operators to utilize the proper facilities.

Contracts

- Incorporate requirements for concrete waste management into concrete supplier and subcontractor agreements.

Location and Placement

- Locate washout area at least 50 feet from sensitive areas, storm drains, open ditches, or water bodies, including wetlands. See Figures 3.7 through 3.9.
- Allow convenient access for concrete trucks, preferably near the area where the concrete is being poured.
- If trucks need to leave a paved area to access washout, prevent track-out with a pad of rock or quarry spalls (see BMP C105). These areas should be far enough away from other construction traffic to reduce the likelihood of accidental damage and spills.
- The number of facilities you install will depend on the expected demand for storage capacity.
- On large sites with extensive concrete work, washouts must be placed in multiple locations for ease of use by concrete truck drivers.

On-Site Concrete Washout Facility, Transit Truck Washout Procedures

- Locate washout area at least 50 feet from sensitive areas, storm drains, open ditches, or water bodies, including wetlands. See Figures 3.7 through 3.9.
- Concrete washout facilities shall be constructed and maintained in sufficient quantity and size to contain all liquid and concrete waste generated by washout operations with a freeboard of 12 inches.
- Washout of concrete trucks shall be performed in designated areas only.

- Concrete washout from concrete pumper bins can be washed into concrete pumper trucks and discharged into designated washout area or properly disposed of off site.
- See maintenance standards below for concrete waste disposal requirements.
- Concrete Washout Facility:
 - Temporary concrete washout facilities (either above or below grade) should be constructed as shown on the representative details below, with a recommended minimum length and minimum width of 10 feet. The quantity and volume must be sufficient to contain all liquid and concrete waste generated by washout operations.
 - Lath and flagging shall be commercial type.
 - Plastic lining material shall be a minimum of 10 mil polyethylene sheeting and must be free of holes, tears, or other defects that compromise the impermeability of the material.
 - Liner seams shall be installed in accordance with manufacturers' recommendations.
 - Soil base shall be prepared free of rocks or other debris that may cause tears or holes in the plastic lining material.

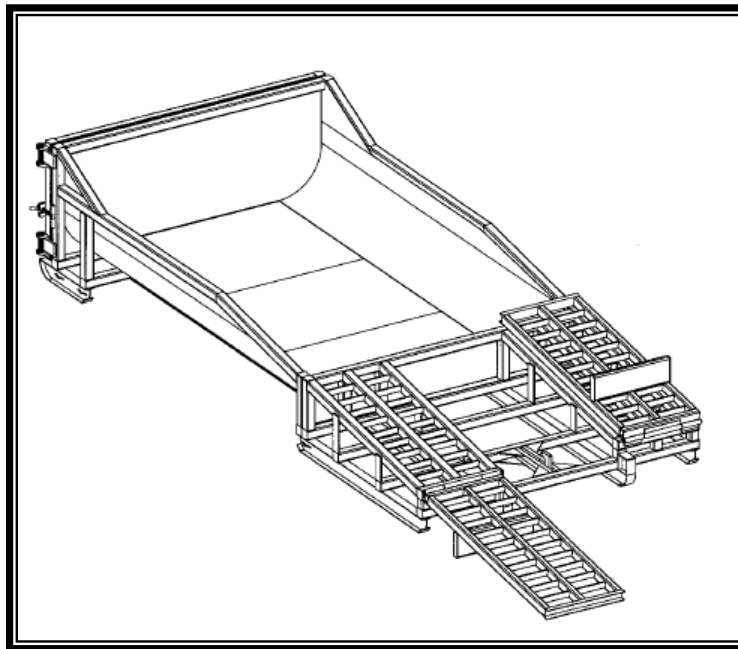

Figure 3.7. Prefabricated Concrete Washout Container with Ramp.

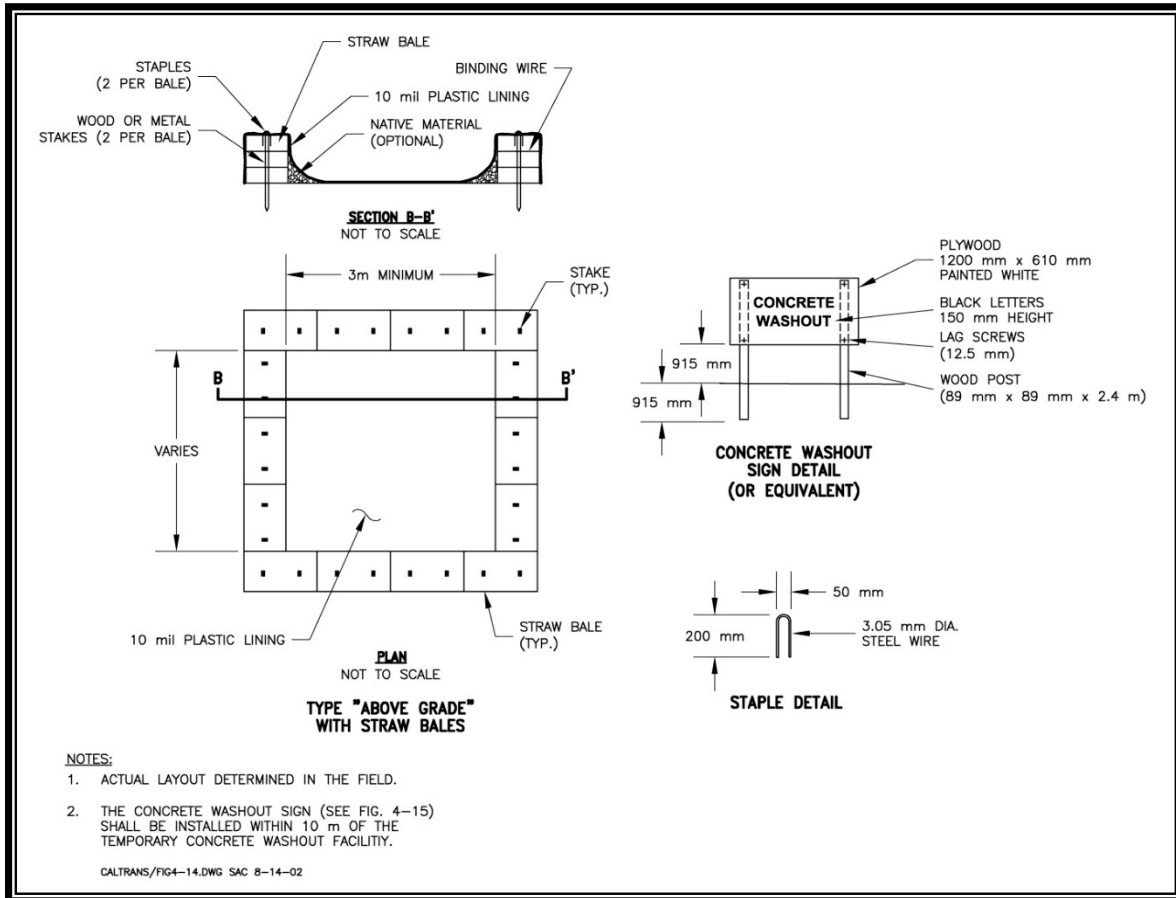

Figure 3.8. Concrete Washout Area A.

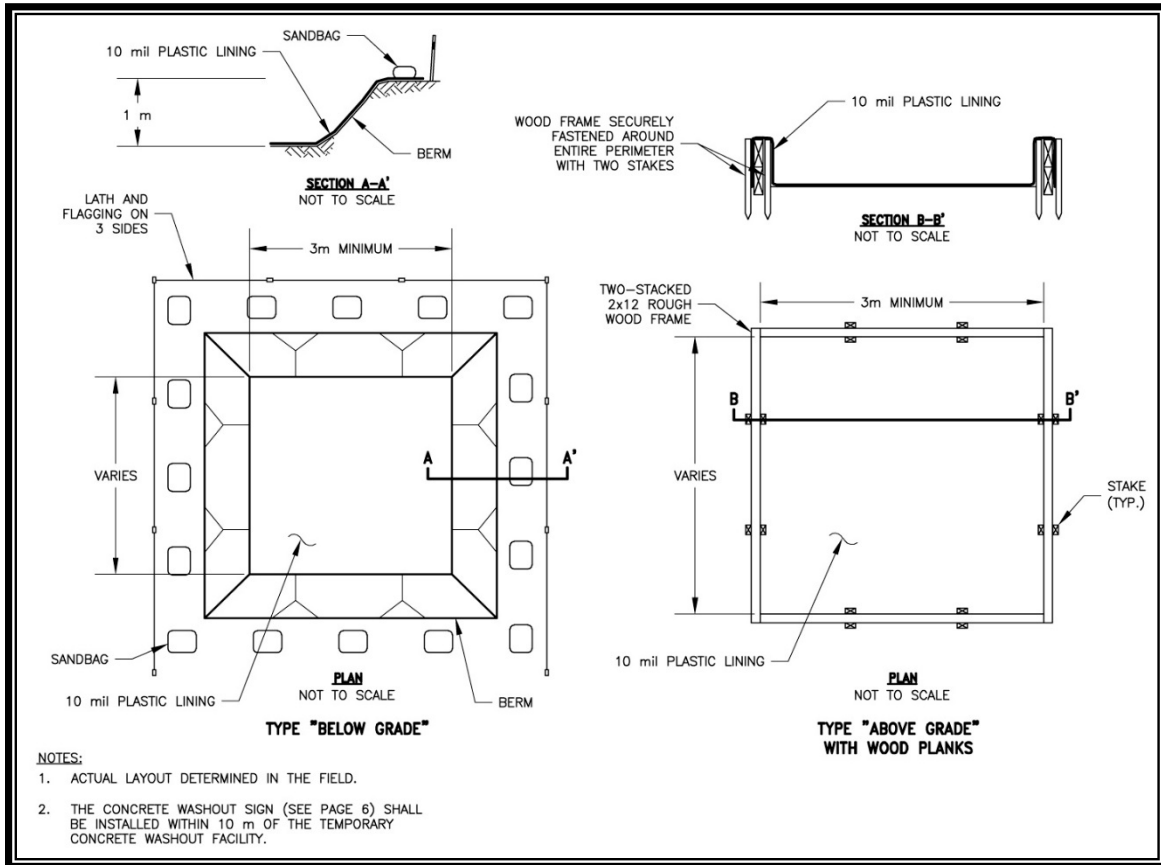

Figure 3.9. Concrete Washout Area B.

Maintenance Standards

Inspection and Maintenance

- Inspect and verify that concrete washout BMPs are in place prior to the commencement of concrete work. This inspection shall be included in the SWPPP inspection checklist.
- During periods of concrete work, inspect daily to verify continued performance.
 - Check overall condition and performance
 - Check remaining capacity (percent full)
 - If using self-installed washout facilities, verify plastic liners are intact and sidewalls are not damaged
 - If using prefabricated containers, check for leaks.
- Washout facilities shall be maintained to provide adequate holding capacity with a minimum freeboard of 12 inches.

- Washout facilities must be cleaned, or new facilities must be constructed and ready for use once the washout is 75 percent full or only 12 inches of freeboard remains, whichever occurs first.
- If the washout is nearing capacity, vacuum and dispose of the waste material in an approved manner.
 - Do not discharge liquid or slurry to waterways, storm drains or directly onto ground. Pump or vacuum the liquid or slurry out of the facility and dispose of it off site at a facility that accepts this material.
 - Do not use sanitary sewer without a permit that must be obtained from the LOTT Clean Water Alliance at 360-528-5708.
 - Place a secure, non-collapsing, non-water collecting cover over the concrete washout facility prior to predicted wet weather to prevent accumulation and overflow of precipitation.
 - Remove and dispose of hardened concrete and return the structure to a functional condition. Concrete may be reused on site or hauled away for disposal or recycling.
- When you remove materials from the self-installed concrete washout, build a new structure; or, if the previous structure is still intact, inspect for signs of weakening or damage, and make any necessary repairs. Re-line the structure with new plastic after each cleaning.

Removal of Temporary Concrete Washout Facilities

- When temporary concrete washout facilities are no longer required for the work, the hardened concrete, slurries and liquids shall be removed and properly disposed of.
- Materials used to construct temporary concrete washout facilities shall be removed from the site of the work and disposed of or recycled.
- Holes, depressions or other ground disturbance caused by the removal of the temporary concrete washout facilities shall be backfilled, repaired, and stabilized to prevent erosion.

BMP C160: Certified Erosion and Sediment Control Lead

Purpose

The project applicant designates at least one person as the responsible representative in charge of erosion and sediment control, and water quality protection. The designated person shall be the CESCL who is responsible for ensuring compliance with all local, state, and federal Construction SWPPP and water quality requirements.

Conditions of Use

A CESCL shall be made available on projects required to prepare a Construction SWPPP and that discharge stormwater to surface waters of the state. For projects that require a SWPPP Short Form, a CESCL is required during preparation of the document. Any modifications must be approved by the CESCL. Projects disturbing less than 1 acre and without potential to discharge stormwater off site may have a person without CESCL certification conduct inspections, though a CESCL is highly recommended. Ecology maintains a list of erosion and sediment control training and certification providers at: <https://ecology.wa.gov/Regulations-Permits/Permits-certifications/Certified-erosion-sediment-control>.

The CESCL shall:

- Have a current certificate proving attendance in an erosion and sediment control training course that meets the minimum training and certification requirements established by Ecology (see details below).

OR

- Be a Certified Professional in Erosion and Sediment Control (CPESC); for additional information go to: www.cpesc.net.

Specifications

- Certification shall remain valid for 3 years.
- The CESCL shall have authority to act on behalf of the contractor or developer and shall be available, or on call, 24 hours per day throughout the period of construction.
- The Construction SWPPP shall include the name, telephone number, email address, and address of the designated CESCL.
- A CESCL may provide inspection and compliance services for multiple construction projects in the same geographic region.

Duties and responsibilities of the CESCL shall include, but are not limited to the following:

- Maintaining permit file on site at all times, which includes the Construction SWPPP and any associated permits and plans.
- Directing BMP installation, inspection, maintenance, modification, and removal.
- Updating all project drawings and the Construction SWPPP with changes made.
- Completing any sampling requirements including reporting results using Web Discharge Monitoring Reports.
- Keeping daily logs, and inspection reports. Inspection reports must include:
 - Inspection date/time.
 - Weather information; general conditions during inspection and approximate amount of precipitation since the last inspection.
 - A summary or list of all BMPs implemented, including observations of all erosion/sediment control structures or practices. The following shall be noted:
 - Locations of BMPs inspected
 - Locations of BMPs that need maintenance
 - Locations of BMPs that failed to operate as designed or intended
 - Locations of where additional or different BMPs are required
 - Visual monitoring results, including a description of discharged stormwater. The presence of suspended sediment, turbid water, discoloration, and oil sheen shall be noted, as applicable.
 - Any water quality monitoring performed during inspection.
 - General comments and notes, including a brief description of any BMP repairs, maintenance or installations made as a result of the inspection.
- Facilitate, participate in, and take corrective actions resulting from inspections performed by outside agencies or the owner.

BMP C162: Scheduling

Purpose

Sequencing a construction project reduces the amount and duration of soil exposed to erosion by wind, rain, runoff, and vehicle tracking.

Conditions of Use

The construction sequence schedule is an orderly listing of all major land-disturbing activities together with the necessary erosion and sedimentation control measures planned for the project. This type of schedule guides the contractor on work to be done before other work is started so that serious erosion and sedimentation problems can be avoided.

Following a specified work schedule that coordinates the timing of land-disturbing activities and the installation of control measures is perhaps the most cost-effective way of controlling erosion during construction. The removal of surface ground cover leaves a site vulnerable to accelerated erosion. Construction procedures that limit land clearing, provide timely installation of erosion and sedimentation controls, and restore protective cover quickly can significantly reduce the erosion potential of a site.

Design Considerations

- Minimize construction during rainy periods.
- Schedule projects to disturb only small portions of the site at any one time. Complete grading as soon as possible. Immediately stabilize the disturbed portion before grading the next portion. Practice staged seeding in order to revegetate cut and fill slopes as the work progresses.

3.2 Runoff Conveyance and Treatment BMPs

This section contains the standards and specifications for Runoff Conveyance and Treatment BMPs. Table 3.10 shows the relationship of the BMPs in Section 3.2 to the Construction SWPPP elements described in Section 2.3.3.

Effective implementation of source control measures in Section 3.1 throughout the construction site will reduce the generation of turbid water and may reduce the effort required to maintain treatment BMPs in this section.

Table 3.10. Runoff Conveyance and Treatment BMPs by SWPPP Element.

BMP or Element Name	Element #3 Control Flow Rates	Element #4 Install Sediment Controls	Element #6 Protect Slopes	Element #7 Protect Storm Drain Inlets	Element #8 Stabilize Channels and Outlets	Element #9 Control Pollutants	Element #10 Control Dewatering	Element #13 Protect Low Impact Development
BMP C200: Interceptor Dike and Swale			✓					✓
BMP C201: Grass-Lined Channels			✓					✓
BMP C202: Channel Lining					✓			
BMP C203: Water Bars	✓		✓				✓	
BMP C204: Pipe Slope Drains			✓					
BMP C205: Subsurface Drains			✓					
BMP C206: Level Spreader			✓				✓	
BMP C207: Check Dams	✓		✓		✓			✓
BMP C208: Triangular Silt Dike (TSD) (Geotextile Encased Check Dam)			✓					✓
BMP C209: Outlet Protection	✓				✓			
BMP C220: Storm Drain Inlet Protection				✓				
BMP C231: Brush Barrier		✓						✓
BMP C232: Gravel Filter Berm		✓						
BMP C233: Silt Fence		✓						✓
BMP C234: Vegetated Strip		✓						✓
BMP C235: Wattles	✓	✓						
BMP C236: Vegetated Filtration							✓	
BMP C240: Sediment Trap	✓	✓						
BMP C241: Temporary Sediment Pond	✓	✓						
BMP C250: Construction Stormwater Chemical Treatment		✓				✓		
BMP C251: Construction Stormwater Filtration		✓				✓		
BMP C252: High pH Neutralization Using CO ₂						✓		
BMP C253: pH Control for High pH Water						✓		

BMP C200: Interceptor Dike and Swale

Purpose

Provide a ridge of compacted soil, or a ridge with an upslope swale, at the top or base of a disturbed slope or along the perimeter of a disturbed construction area to convey stormwater. Use the dike and/or swale to intercept the runoff from unprotected areas and direct it to areas where erosion can be controlled. This can prevent storm runoff from entering the work area or sediment-laden runoff from leaving the construction site.

Conditions of Use

Where the runoff from an exposed site or disturbed slope must be conveyed to an erosion control facility that can safely contain the stormwater:

- Locate upslope of a construction site to prevent runoff from entering disturbed area
- When placed horizontally across a disturbed slope, it reduces the amount and velocity of runoff flowing down the slope.
- Locate downslope to collect runoff from a disturbed area and direct water to a sediment basin

Design and Installation Specifications

- Dike and/or swale and channel must be stabilized with temporary or permanent vegetation or other channel protection during construction.
- Channel requires a positive grade for drainage; steeper grades require channel stabilization (BMP C202 or B122) and check dams (BMP C207).
- Review construction for areas where overtopping may occur.
- Can be used at top of new fill before vegetation is established.
- May be used as a permanent diversion channel to carry the runoff.
- Subbasin tributary area to the dike or swale shall be 1 acre or less.
- Design capacity for the peak flow from a 10-year, 24-hour storm event assuming an NRCS Type 1A rainfall distribution resolved to 10-minute time steps, for temporary facilities. Alternatively, use 1.6 times the 10-year, 1-hour time step flow indicated by an approved continuous runoff model. If a 15-minute (or less) time step is used, no correction factor is required. For conveyance systems that will also serve on a permanent basis see design standards in Volume III, Chapter 4.

- **Interceptor dikes** shall meet the following criteria:
 - Top Width: 2 feet minimum
 - Height: 1.5 feet minimum on berm
 - Side Slope: 2H:1V or flatter
 - Grade: Depends on topography; however, dike system minimum is 0.5 percent, maximum is 1 percent
 - Compaction: Minimum of 90 percent ASTM D698 standard proctor.
 - Horizontal Spacing of Interceptor Dikes:

Average Slope	Slope Percent	Flowpath Length
>20H:1V or flatter	3% to <5%	300 feet
(>10 to 20)H:1V	5% to <10%	200 feet
(>4 to 10)H:1V	10% to <25%	100 feet
(2 to 4)H:1V	25% to 50%	50 feet

- Stabilization depends on velocity and reach:
 - Slopes <5 percent: Seed and mulch applied within 5 days of dike construction (see BMP C121: Mulching).
 - Slopes 5 to 40 percent: Dependent on runoff velocities and dike materials. Stabilization should be done immediately using either sod or riprap or other measures to avoid erosion.
- The upslope side of the dike shall provide positive drainage to the dike outlet. No erosion shall occur at the outlet. Provide energy dissipation measures as necessary. Sediment-laden runoff must be released through a sediment trapping facility.
- Minimize construction traffic over temporary dikes. Use temporary cross culverts for channel crossing.
- **Interceptor swales** shall meet the following criteria:
 - Bottom Width: 2 foot minimum; the cross-section bottom shall be level.
 - Depth: 1-foot minimum.
 - Side Slope: 2H:1V or flatter.
 - Grade: Maximum 5 percent, with positive drainage to a suitable outlet (such as a sediment pond).

- Stabilization: Seed per BMP C120: Temporary and Permanent Seeding or BMP C202: Channel Lining. For channel lining, use a layer of riprap (12 inches thick) pressed into the bank and extending at least 8 inches vertically up from the bottom of the channel.
- Inspect diversion dikes and interceptor swales once a week and after every rainfall. Immediately remove sediment from the flow area.
- Damage caused by construction traffic or other activity must be repaired before the end of each working day.
- Check outlets and make timely repairs as needed to avoid gully formation. When the area below the temporary diversion dike is permanently stabilized, remove the dike and fill and stabilize the channel to blend with the natural surface.

BMP C201: Grass-Lined Channels

Purpose

To provide a channel with a vegetative lining for conveyance of runoff. See Figure 3.10 for typical grass-lined channels.

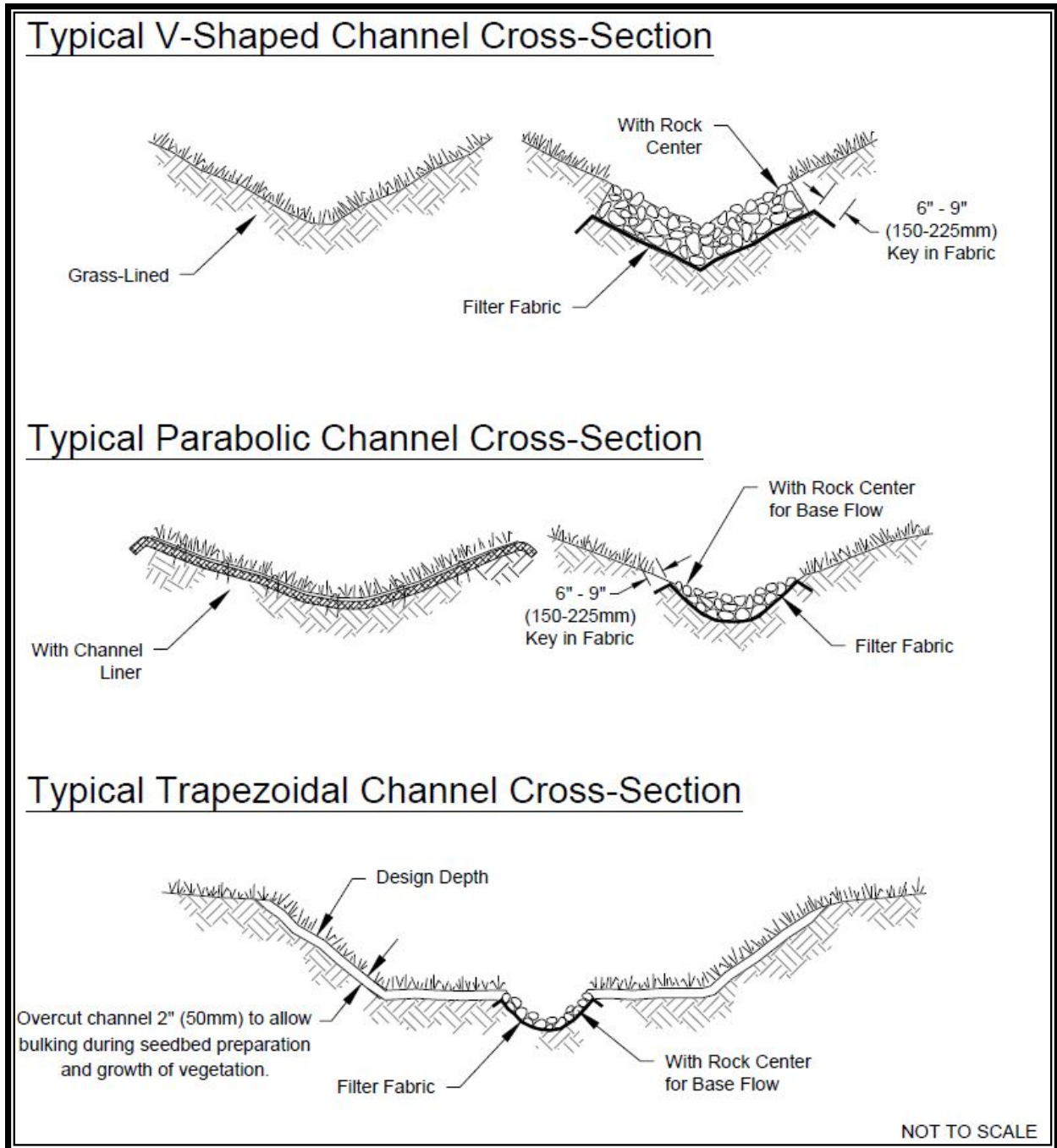

Figure 3.10. Typical Grass-Lined Channels.

Conditions of Use

This practice applies to construction sites where concentrated runoff needs to be contained to prevent erosion or flooding.

- When a vegetative lining can provide sufficient stability for the channel cross-section and at lower velocities of water (normally dependent on grade). This means that the channel slopes are generally less than 5 percent and space is available for a relatively large cross-section.
- Typical uses include roadside ditches, channels at property boundaries, outlets for diversions, and other channels and drainage ditches in low areas.
- Channels that will be vegetated should be installed before major earthwork and hydroseeded with a BFM. The vegetation should be well established (i.e., 75 percent cover) before water is allowed to flow in the ditch. With channels that will have high flows, erosion control blankets should be installed over the hydroseed. If vegetation cannot be established from seed before water is allowed in the ditch, sod must be installed in the bottom of the ditch in lieu of hydromulch and blankets.

Design and Installation Specifications

- Locate channel where it can conform to the topography and other features such as roads.
- Locate channel to use natural drainage systems to the greatest extent possible.
- Avoid sharp changes in alignment or bends and changes in grade.
- Do not reshape the landscape to fit the drainage channel.
- The maximum design velocity shall be based on soil conditions, type of vegetation, and method of revegetation, but at no time shall velocity exceed 5 feet per second. The channel shall not be overtopped by the peak runoff from a 10-year, 24-hour storm event, assuming a NRCS Type 1A rainfall distribution resolved to 10-minute time steps. Alternatively, use 1.6 times the 10-year, 1-hour time step flow indicated by an approved continuous runoff model to determine a flow rate that the channel must contain. If a 15-minute (or less) time step is used, no correction factor is required.
- Where the grass-lined channel will also function as a permanent stormwater conveyance facility, the channel must meet the drainage conveyance requirements defined in Volume III, Chapter 4.
- An established grass or vegetated lining is required before the channel can be used to convey stormwater, unless stabilized with nets or blankets.

- If design velocity of a channel to be vegetated by seeding exceeds 2 feet per second, a temporary channel liner is required. Geotextile or special mulch protection such as straw or netting provides stability until the vegetation is fully established. See Figure 3.11.

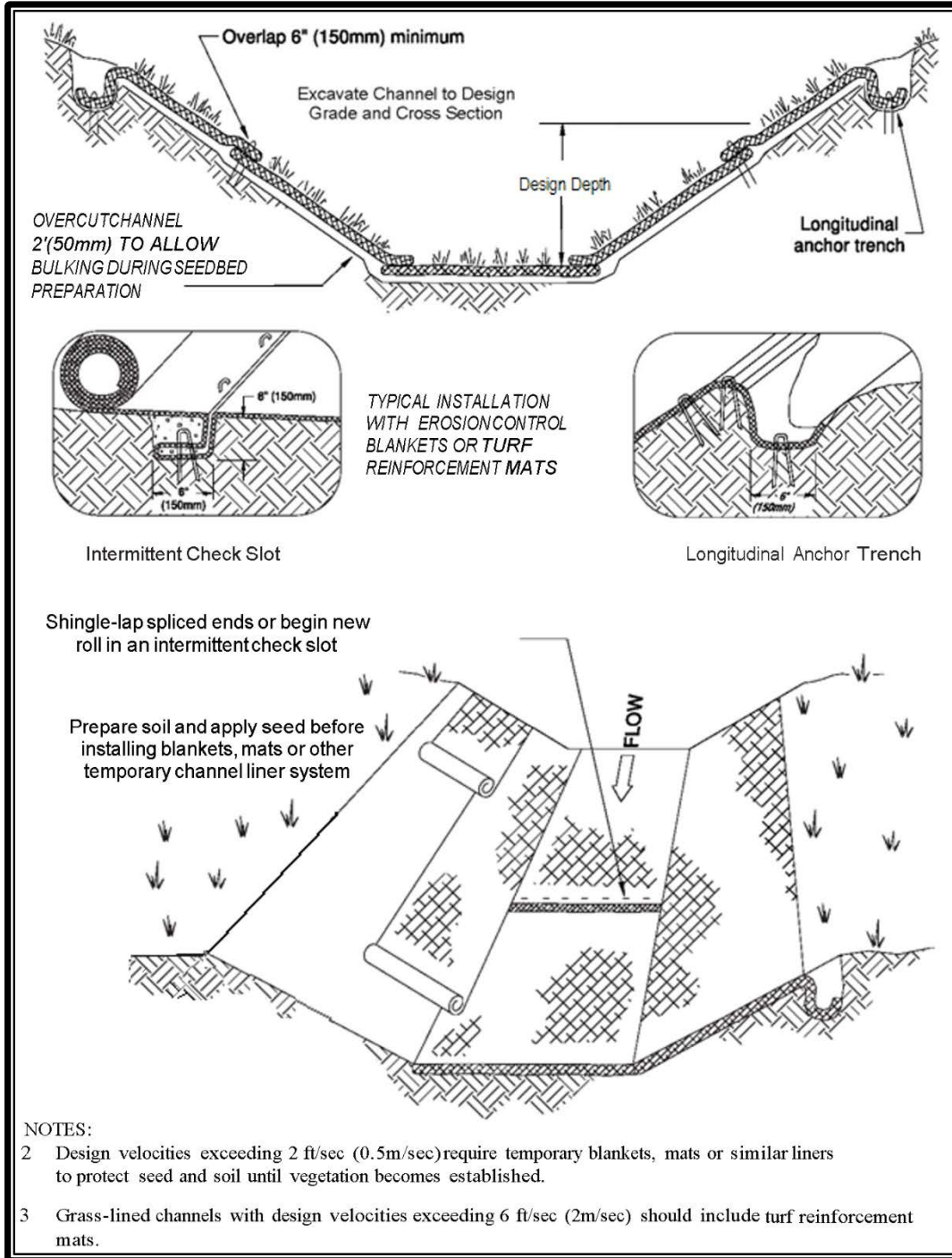

Figure 3.11. Temporary Channel Liners.

- Check dams shall be removed once the grass roots and aboveground biomass have grown enough to stabilize soils and sufficiently protect the swale bottom and side slopes from erosion. Check dams will remain when swale slopes are greater than 4 percent for long term erosion protection. The area beneath the check dams shall be seeded and mulched immediately after dam removal.
- If vegetation is established by sodding, the permissible velocity for established vegetation may be used and no temporary liner is needed.
- Do not subject grass-lined channel to sedimentation from disturbed areas. Use sediment-trapping BMPs upstream of the channel.
- **V-shaped grass channels** generally apply where the quantity of water is small, such as in short reaches along roadsides. The V-shaped cross-section is least desirable because it is difficult to stabilize the bottom where velocities may be high.
- **Trapezoidal grass channels** are used where runoff volumes are large and slope is low so that velocities are nonerosive to vegetated linings. (Note: it is difficult to construct small parabolic shaped channels.)
- Subsurface drainage, or riprap channel bottoms, may be necessary on sites that are subject to prolonged wet conditions due to long duration flows or a high water table.
- Provide outlet protection at culvert ends and at channel intersections.
- Grass channels, at a minimum, must carry peak runoff for temporary construction drainage facilities from the 10-year, 24-hour storm without eroding. Where flood hazard exists, increase the capacity according to the potential damage.
- Grassed channel side slopes generally are constructed 3H:1V or flatter to aid in the establishment of vegetation and for maintenance.
- Construct channels a minimum of 0.2 foot larger around the periphery to allow for soil bulking during seedbed preparations and sod buildup.

Maintenance Standards

- During the establishment period, check grass-lined channels for erosion or mulch washoff after every rainfall.
- After grass is established, periodically check the channel; check it after every runoff event. Immediately make repairs.
 - It is particularly important to check the channel outlet and all road crossings for bank stability and evidence of piping or scour holes.

- Remove all significant sediment accumulations to maintain the designed carrying capacity. Keep the grass in a healthy, vigorous condition at all times, since it is the primary erosion protection for the channel.

BMP C202: Channel Lining

Purpose

To protect channels by providing a channel liner using either blankets or riprap.

Conditions of Use

Channel lining must be used when natural soils or vegetated stabilized soils in a channel are not adequate to prevent channel erosion.

- When a permanent ditch or pipe system is to be installed and a temporary measure is needed.
- In almost all cases, synthetic and organic coconut blankets are more effective than riprap for protecting channels from erosion. Blankets can be used with and without vegetation. Blanketed channels can be designed to handle any expected flow and longevity requirement. Some synthetic blankets have a predicted life span of 50 years or more, even in sunlight.
- Other reasons why blankets are better than rock include the availability of blankets over rock. In many areas of the state, rock is not easily obtainable or is very expensive to haul to a site. Blankets can be delivered anywhere. Rock requires the use of dump trucks to haul and heavy equipment to place. Blankets usually only require laborers with hand tools, and sometimes a backhoe.
- The Federal Highway Administration recommends not using flexible liners whenever the slope exceeds 10 percent or the shear stress exceeds 8 pounds per square foot.

Design and Installation Specifications

See BMP C122 for information on blankets.

Since riprap is used where erosion potential is high, construction must be sequenced so that the riprap is put in place with the minimum possible delay.

- Disturbance of areas where riprap is to be placed should be undertaken only when final preparation and placement of the riprap can follow immediately behind the initial disturbance. Where riprap is used for outlet protection, the riprap should be placed before or in conjunction with the construction of the pipe or channel so that it is in place when the pipe or channel begins to operate.
- The designer, after determining the riprap size that will be stable under the flow conditions, shall consider that size to be a minimum size and then, based on riprap gradations available in the area, select the size or sizes that equal or exceed the minimum size. The possibility of drainage structure damage by children shall be

considered in selecting a riprap size, especially if there is nearby water or a gully in which to toss the stones.

- Stone for riprap shall consist of field stone or quarry stone of approximately rectangular shape. The stone shall be hard and angular and of such quality that it will not disintegrate on exposure to water or weathering and it shall be suitable in all respects for the purpose intended.
- A lining of engineering filter fabric (geotextile) shall be placed between the riprap and the underlying soil surface to prevent soil movement into or through the riprap. The geotextile should be keyed in at the top of the bank.
- Filter fabric shall not be used on slopes greater than 1.5H:1V as slippage may occur. Use it in conjunction with a layer of coarse aggregate (granular filter blanket) when the riprap to be placed is 12 inches and larger.

BMP C203: Water Bars

Purpose

A small ditch or ridge of material is constructed diagonally across a road or right-of-way to divert stormwater runoff from the road surface, wheel tracks, or a shallow road ditch. See Figure 3.12.

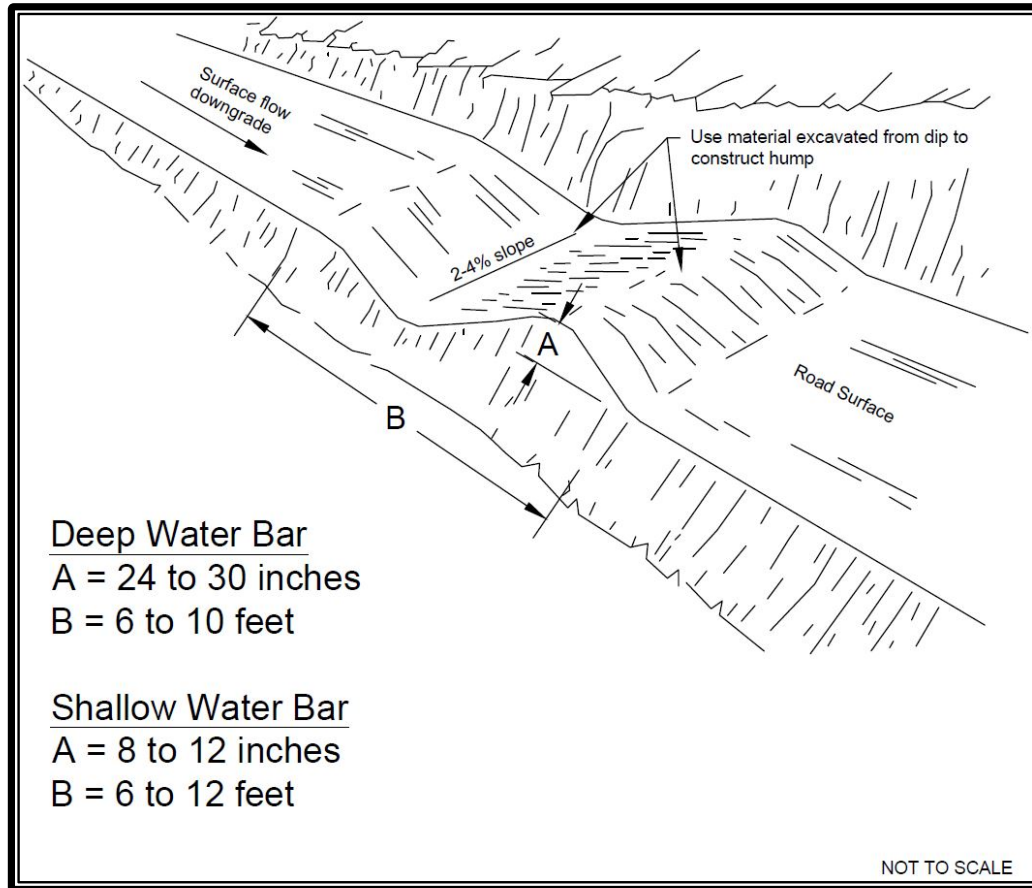

Figure 3.12. Water Bar.

Conditions of Use

Clearing right-of-way and construction of access for power lines, pipelines, and other similar installations often require long, narrow rights-of-way over sloping terrain. Disturbance and compaction promotes gully formation in these cleared strips by increasing the volume and velocity of runoff. Gully formation may be especially severe in tire tracks and ruts. To prevent gulying, runoff can often be diverted across the width of the right-of-way to undisturbed areas by using small predesigned diversions.

- Give special consideration to each individual outlet area, as well as to the cumulative effect of added diversions. Use gravel to stabilize the diversion where significant vehicular traffic is anticipated.

Design and Installation Specifications

- Height: 8-inch minimum measured from the channel bottom to the ridge top.
- Side slope of channel: 2H:1V maximum; 3H:1V or flatter when vehicles will cross.
- Base width of ridge: 6-inch minimum.
- Locate water bars to use natural drainage systems and to discharge into well vegetated stable areas.
- Guidelines for spacing:

Average Slope	Slope Percent	Spacing (feet)
> 20H:1V or flatter	<5%	125
(> 10 to 20) H:1V	5% to <10%	100
(> 5 to 10) H:1V	10% to <20%	75
(> 2.86 to 5) H:1V	20% to <35%	50
2.86 H:1V or steeper	≥35%	Use rock lined ditch

- Grade of water bar and angle: Select angle that results in ditch slope less than 2 percent.
- Install as soon as the clearing and grading is complete.
- Reconstruct/repair as soon as possible when disturbed by grading or excavation.
- Compact the ridge when installed.
- Stabilize, seed and mulch the portions that are not subject to traffic. Gravel the areas crossed by vehicles.

Maintenance Standards

- Periodically inspect right-of-way diversions for wear and after runoff events for erosion damage.
- Immediately remove sediment from the flow area and repair the dike when problems are identified.
- Check outlet areas and make timely repairs as needed.
- When permanent road drainage is established and the area above the temporary right-of-way diversion is permanently stabilized, remove the dikes and fill the channel to blend with the natural ground, and appropriately stabilize the disturbed area.

BMP C204: Pipe Slope Drains***Purpose***

To use a pipe to convey stormwater anytime water needs to be diverted away from or over bare soil to prevent gullies, channel erosion, and saturation of slide-prone soils.

Conditions of Use

Pipe slope drains should be used when a temporary or permanent stormwater conveyance is needed to move the water down a steep slope to avoid erosion (Figure 3.13).

On highway projects, pipe slope drains should be used at bridge ends to collect runoff and pipe it to the base of the fill slopes along bridge approaches. These can be designed into a project and included as bid items.

Another use on road projects is to collect runoff from pavement and pipe it away from side slopes. These are useful because there is generally a time lag between having the first lift of asphalt installed and the curbs, gutters, and permanent drainage installed. Used in conjunction with sand bags, or other temporary diversion devices, these will prevent massive amounts of sediment from leaving a project.

Water can be collected, channeled with sand bags, Triangular Silt Dikes, berms, or other material, and piped to temporary sediment ponds.

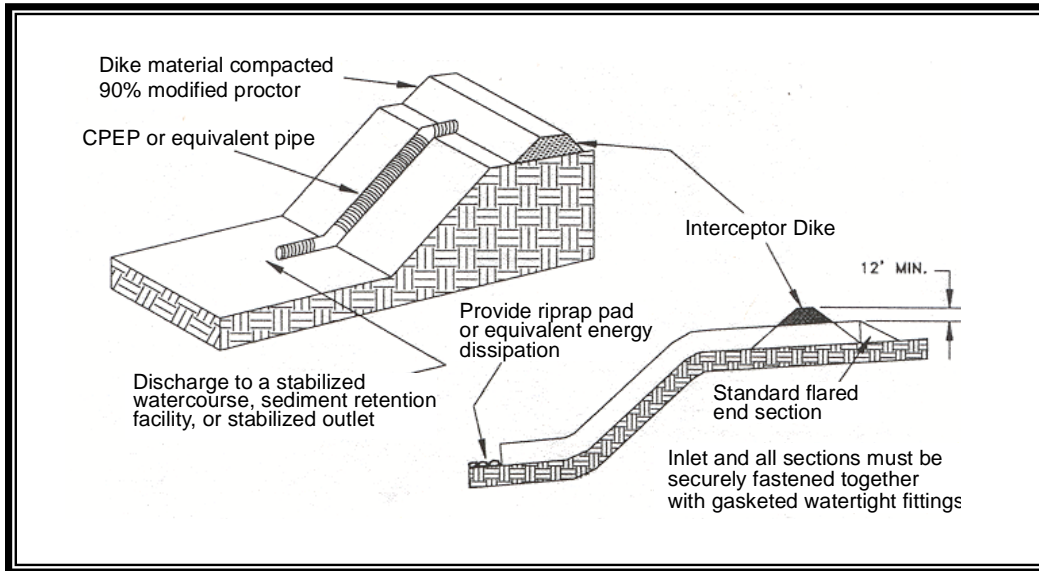

Figure 3.13. Pipe Slope Drain.

Pipe slope drains can be:

- Connected to new catch basins and used temporarily until all permanent piping is installed
- Used to drain water collected from aquifers exposed on cut slopes and take it to the base of the slope
- Used to collect clean runoff from plastic sheeting and direct it away from exposed soil
- Installed in conjunction with silt fence to drain collected water to a controlled area
- Used to divert small seasonal streams away from construction. They have been used successfully on culvert replacement and extension jobs. Large flex pipe can be used on larger streams during culvert removal, repair, or replacement.
- Connected to existing downspouts and roof drains and used to divert water away from work areas during building renovation, demolition, and construction projects

Design and Installation Specifications

Size the pipe to convey the flow. The capacity for temporary drains shall be sufficient to handle the peak flow from a 10-year, 24-hour storm event assuming a NRCS Type 1A rainfall distribution resolved to 10-minute time steps. Alternatively, use 1.6 times the 10-year, 1-hour time-step flow indicated by an approved continuous runoff model. If a 15-minute (or less) time step is used, no correction factor is required.

- Use care in clearing vegetated slopes for installation.
- Re-establish cover immediately on areas disturbed by installation.
- Use temporary drains on new cut or fill slopes.
- Use diversion dikes or swales to collect water at the top of the slope.
- Ensure that the inlet area is stable and large enough to direct flow into the pipe. There are now several commercially available collectors that are attached to the pipe inlet and help prevent erosion at the inlet.
- Dike material shall be compacted to 90 percent modified proctor to prevent piping of water through the berm. The entrance area is a common failure location.
- The entrance shall consist of a standard flared end section for culverts 12 inches and larger with a minimum 6-inch metal toe plate to prevent runoff from undercutting the pipe inlet. The slope of the entrance shall be at least 3 percent. Sand bags may also be used at pipe entrances as a temporary measure.
- The soil around and under the pipe and entrance section shall be thoroughly compacted to prevent undercutting.
- The flared inlet section shall be securely connected to the slope drain and have watertight connecting bands.
- Slope drain sections shall be securely fastened together, fused or have gasketed watertight fittings, and shall be securely anchored into the soil.
- Thrust blocks must be installed anytime 90 degree or sharper bends are utilized. Depending on size of pipe and flow, these can be constructed with sand bags, straw bales staked in place, T- posts and wire, or ecology blocks.
- Pipe needs to be secured along its full length to prevent movement. This can be done with steel T- posts and wire. A post is installed on each side of the pipe and the pipe is wired to them. This should be done approximately every 10 to 20 feet of pipe length or so, depending on the size of the pipe and quantity of water to be diverted.
- Interceptor dikes shall be used to direct runoff into a slope drain. The height of the dike shall be at least 1 foot higher at all points than the top of the inlet pipe.
- The area below the outlet must be stabilized with a riprap apron (see BMP C209: Outlet Protection, for the appropriate outlet material).

- If the pipe slope drain is conveying sediment-laden water, direct all flows into a sediment trapping facility.
- Materials specifications for any permanent piped system are listed in Volume III, and shall be approved by the city.

Maintenance Standards

- Check inlet and outlet points regularly, especially after runoff events.
- The inlet must be free of undercutting, and no water should be going around the point of entry. If there are problems, the headwall shall be reinforced with compacted earth or sand bags.
- The outlet point must be free of erosion and installed with appropriate outlet protection.
- Remove debris from pipe.

BMP C205: Subsurface Drains

Purpose

To intercept, collect, and convey groundwater to a satisfactory outlet, using a perforated pipe or conduit below the ground surface. Subsurface drains are also known as “French drains.” The perforated pipe provides a dewatering mechanism to drain excessively wet soils, provide a stable base for construction, improve stability of structures with shallow foundations, or to reduce hydrostatic pressure to improve slope stability.

Conditions of Use

Use when excessive water must be removed from the soil. The soil permeability, depth to water table and impervious layers are all factors that may govern the use of subsurface drains.

Design and Installation Specifications

- **Relief drains** are used either to lower the water table in large, relatively flat areas, improve the growth of vegetation, or to remove surface water.
 - They are installed along a slope and drain in the direction of the slope.
 - They can be installed in a grid pattern, a herringbone pattern, or a random pattern.
- **Interceptor drains** are used to remove excess groundwater from a slope, stabilize steep slopes, and lower the water table immediately below a slope to prevent the soil from becoming saturated.
 - They are installed perpendicular to a slope and drain to the side of the slope.
 - They usually consist of a single pipe or series of single pipes instead of a patterned layout.
- **Depth and spacing of interceptor drains** – The depth of an interceptor drain is determined primarily by the depth to which the water table is to be lowered or the depth to a confining layer. For practical reasons, the maximum depth is usually limited to 6 feet, with a minimum cover of 2 feet to protect the conduit.
 - The soil should have depth and sufficient permeability to permit installation of an effective drainage system at a depth of 2 to 6 feet.
 - An adequate outlet for the drainage system must be available either by gravity or by pumping.
 - The quantity and quality of discharge needs to be accounted for in the receiving water body (additional detention may be required).

- This standard does not apply to subsurface drains for building foundations or deep excavations.
- The capacity of an interceptor drain is determined by calculating the maximum rate of groundwater flow to be intercepted. Therefore, it is good practice to make complete subsurface investigations, including hydraulic conductivity of the soil, before designing a subsurface drainage system.
- **Size of drain** – Size subsurface drains to carry the required capacity without pressure flow. Minimum diameter for a subsurface drain is 4 inches.
 - The minimum velocity required to prevent silting is 1.4 feet per second. The line shall be graded to achieve this velocity at a minimum. The maximum allowable velocity using a sand-gravel filter or envelope is 9 feet per second.
 - Filter material and fabric shall be used around all drains for proper bedding and filtration of fine materials. Envelopes and filters should surround the drain to a minimum of 3-inch thickness.
 - The outlet of the subsurface drain shall empty into a sediment pond through a catch basin unless the discharge is free of sediment; then it can empty into a receiving water body, swale, or stable vegetated area adequately protected from erosion and undermining.
 - The trench shall be constructed on a continuous grade with no reverse grades or low spots.
 - Soft or yielding soils under the drain shall be stabilized with gravel or other suitable material.
 - Backfilling shall be done immediately after placement of the pipe. No sections of pipe shall remain uncovered overnight or during a rainstorm. Backfill material shall be placed in the trench in such a manner that the drain pipe is not displaced or damaged.
 - Do not install permanent drains near trees to avoid the tree roots that tend to clog the line. Use solid pipe with watertight connections where it is necessary to pass a subsurface drainage system through a stand of trees.
- **Outlet** – Ensure that the outlet of a drain empties into a channel or other watercourse above the normal water level.
 - Secure an animal guard to the outlet end of the pipe to keep out rodents.
 - Use outlet pipe of corrugated metal, cast iron, or heavy-duty plastic without perforations and at least 10 feet long. Do not use an envelope or filter material around the outlet pipe, and bury at least two-thirds of the pipe length.
 - When outlet velocities exceed those allowable for the receiving water body, outlet protection must be provided.

Maintenance Standards

- Subsurface drains shall be checked periodically to ensure that they are free-flowing and not clogged with sediment or roots. Checking may include visual observation of flow at the outlet or video inspection.
- The outlet shall be kept clean and free of debris.
- Trees located too close to a subsurface drain often clog the system with their roots. If a drain becomes clogged, relocate the drain or remove the trees as a last resort. Drain placement should be planned to minimize this problem.
- Where drains are crossed by heavy vehicles use steel plate or boards to prevent the lines from being crushed. After work is complete the line shall be checked to ensure that it was not crushed.

BMP C206: Level Spreader

Purpose

To provide a temporary outlet for dikes and diversions consisting of an excavated depression constructed at zero grade across a slope. To convert concentrated runoff to sheet flow and release it onto areas stabilized by existing vegetation or an engineered filter strip.

Conditions of Use

Use when a concentrated flow of water needs to be dispersed over a large area with existing stable vegetation.

Use only where:

- Slopes are gentle.
- Water volume is relatively low.
- Soil will adsorb most of the low-flow events.
- Downstream area is undisturbed stable vegetation that is part of the project area or an easement has been obtained.

Items to consider are:

1. What is the risk of erosion or damage if the flow may become concentrated?
2. Is an easement required if discharged to adjoining property?
3. Will most of the flow discharge to groundwater and not contribute to surface flow?
4. Is there an unstable area downstream that cannot accept additional groundwater?

Design and Installation Specifications

- Discharge area below the outlet shall be uniform with a slope flatter than 5H:1V.
- Outlet shall be constructed level in a stable, undisturbed soil profile (not on fill).
- The runoff shall not reconcentrate after release unless intercepted by another downstream measure.
- The grade of the channel for the last 20 feet of the dike or interceptor entering the level spreader shall be less than or equal to 1 percent. The grade of the level spreader shall be 0 percent to ensure uniform spreading of storm runoff.

- A 6-inch high gravel berm placed across the level lip shall consist of washed crushed rock, 2- to 4-inch or 0.75-inch to 1.5-inch size.
- The spreader length shall be determined by estimating the peak flow expected from the 10-year, 24-hour design storm event assuming a NRCS Type 1A rainfall distribution resolved to 10-minute time steps. Alternatively, use the peak flow from a 10-year, 15-minute (or less) time step using an approved continuous runoff model. The length of the spreader shall be a minimum of 15 feet for 0.1 cubic foot per second and shall increase by 10 feet for each 0.1 cubic foot per second thereafter to a maximum of 0.5 cubic foot per second per spreader. Use multiple spreaders for higher flows.
- The width of the spreader must be at least 6 feet.
- The depth of the spreader as measured from the lip shall be at least 6 inches and be uniform across the entire length.
- Level spreaders shall be setback 100 feet minimum from the property line unless there is an easement for flow or the flow is directed to a natural drainage course.
- Level spreaders, when installed every so often in grassy swales, keep the flows from concentrating. Materials that can be used include sand bags, lumber, logs, concrete, and pipe. To function properly, the material needs to be installed level and on contour. Figures 3.14 and 3.15 provide a cross-section and a detail of a level spreader. A capped perforated pipe could also be used as a spreader.
- If the level spreader has any low points, flow will concentrate, create channels and may cause erosion.

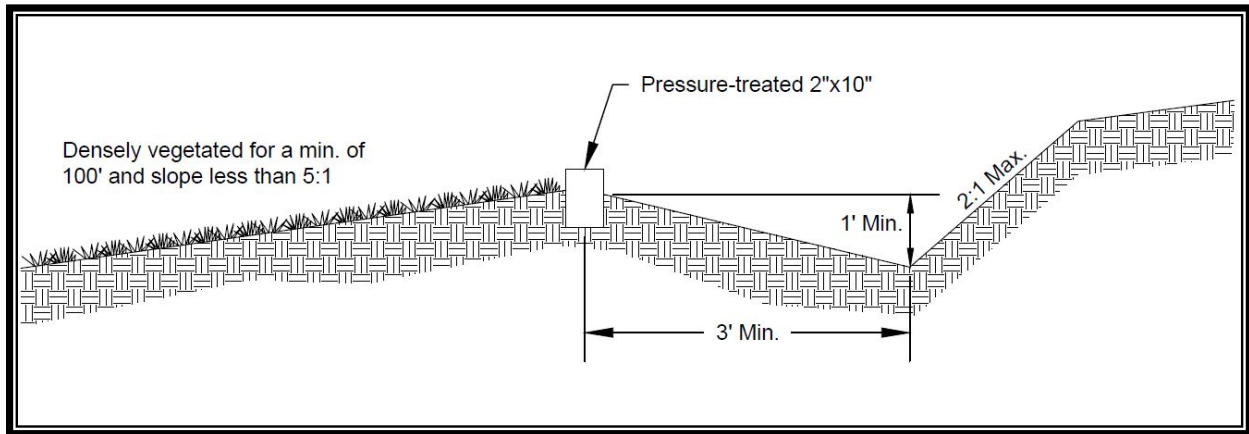

Figure 3.14. Cross-Section of Level Spreader.

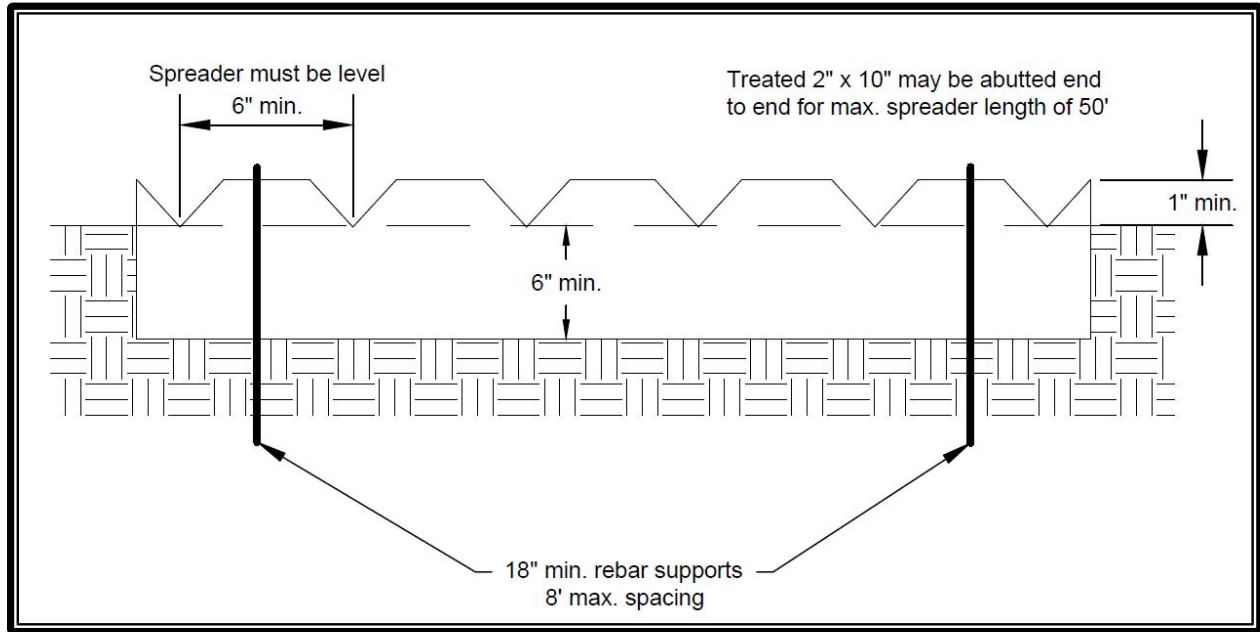

Figure 3.15. Detail of Level Spreader.

Maintenance Standards

- The spreader should be inspected after every runoff event to ensure that it is functioning correctly by spreading water across the vegetated area and not causing concentrated flow or erosion.
- The contractor should avoid the placement of any material on the level spreader and shall prevent construction traffic from crossing over the level spreader.
- If the spreader is damaged by construction traffic, it shall be immediately repaired.

BMP C207: Check Dams



Purpose

Construction of small dams across a swale or ditch reduces the velocity of concentrated flow and dissipates energy.

Conditions of Use

- Where temporary channels or permanent channels are not yet vegetated, channel lining is infeasible, and/or velocity checks are required.
- Check dams may not be placed in streams unless approved by WDFW. Check dams may not be placed in wetlands without approval from the appropriate permitting agency.
- Do not place check dams below the expected backwater from any salmonid bearing water between October 1 and May 31 to ensure that there is no loss of high flow refuge habitat for overwintering juvenile salmonids and emergent salmonid fry.

Design and Installation Specifications

- Construct rock check dams from appropriately sized rock. The rock used must be large enough to stay in place given the expected design flow through the channel. The rock must be placed by hand or by mechanical means (no dumping of rock to form dam) to achieve complete coverage of the ditch or swale and to ensure that the center of the dam is lower than the edges.
- Check dams may also be constructed of either rock or pea-gravel filled bags. Numerous products are also available for this purpose. They tend to be reusable,

quick and easy to install, effective, and cost efficient. Straw bales are not an allowed construction material.

- Place check dams perpendicular to the flow of water.
- The dam should form a triangle when viewed from the side. This prevents undercutting as water flows over the face of the dam rather than falling directly onto the ditch bottom.
- Before installing check dams, impound and bypass upstream water flow away from the work area. Options for bypassing include pumps, siphons, or temporary channels.
- Check dams in association with sumps work more effectively at slowing flow and retaining sediment than just a check dam alone. A deep sump should be provided immediately upstream of the check dam.
- In some cases, if carefully located and designed, check dams can remain as permanent installations with very minor regrading. They may be left as either spillways, in which case accumulated sediment would be graded and seeded, or as check dams to prevent further sediment from leaving the site.
- The maximum spacing between the dams shall be such that the toe of the upstream dam is at the same elevation as the top of the downstream dam.
- Keep the maximum height at 2 feet at the center of the dam.
- Keep the center of the check dam at least 12 inches lower than the outer edges at natural ground elevation.
- Keep the side slopes of the check dam at 2H:1V or flatter.
- Key the stone into the ditch banks and extend it beyond the abutments a minimum of 18 inches to avoid washouts from overflow around the dam.
- Use filter fabric foundation under a rock or sand bag check dam. If a blanket ditch liner is used, filter fabric is not necessary. A piece of organic or synthetic blanket cut to fit will also work for this purpose.
- In the case of grass-lined ditches and swales, all check dams and accumulated sediment shall be removed when the grass has matured sufficiently to protect the ditch or swale – unless the slope of the swale is greater than 4 percent. The area beneath the check dams shall be seeded and mulched immediately after dam removal.
- Ensure that channel appurtenances, such as culvert entrances below check dams, are not subject to damage or blockage from displaced stones. Figure 3.17 depicts a typical rock check dam.

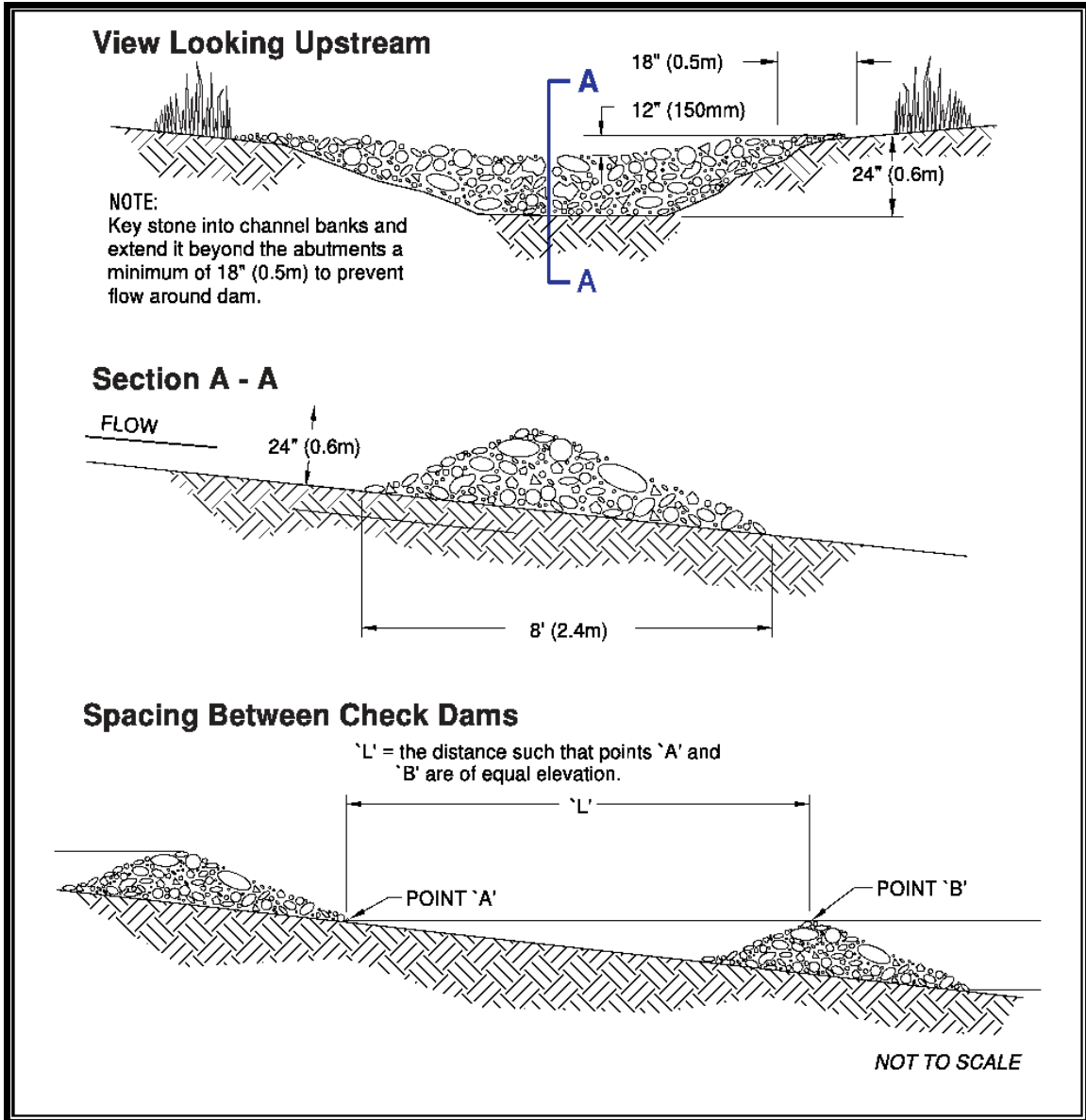

Figure 3.17. Check Dams.

Maintenance Standards

- Check dams shall be monitored for performance and sediment accumulation during and after each runoff event. Sediment shall be removed when it reaches one half the sump depth or one-half of the dam height.
- Anticipate submergence and deposition above the check dam and erosion from high flows around the edges of the dam.
- If significant erosion occurs between dams, install a protective riprap liner in that portion of the channel.

BMP C208: Triangular Silt Dike (TSD) (Geotextile-Encased Check Dam)



Purpose

Triangular silt dikes may be used as check dams for perimeter protection, for temporary soil stockpile protection, for drop inlet protection, or as a temporary interceptor dike.

Conditions of Use

- May be used on soil or pavement with adhesive or staples.
- TSDs have been used to build temporary:
 - Sediment ponds
 - Diversion ditches
 - Concrete washout facilities
 - Curbing
 - Water bars
 - Level spreaders
 - Berms

Design and Installation Specifications

- Made of urethane foam sewn into a woven geosynthetic fabric.
- It is triangular, 10 inches to 14 inches high in the center, with a 20-inch to 28-inch base. A 2-foot apron extends beyond both sides of the triangle along its standard section of 7 feet. A sleeve at one end allows attachment of additional sections as needed.
- Install with ends curved up to prevent water from flowing around the ends.
- The fabric flaps and check dam units are attached to the ground with wire staples. Wire staples should be No. 11 gauge wire and should be 200 millimeters to 300 millimeters in length.
- When multiple units are installed, the sleeve of fabric at the end of the unit shall overlap the abutting unit and be stapled.
- Check dams should be located and installed as soon as construction will allow.
- Check dams should be placed perpendicular to the flow of water.
- When used as check dams, the leading edge must be secured with rocks, sandbags, or a small key slot and staples.
- In the case of grass-lined ditches and swales, check dams and accumulated sediment shall be removed when the grass has matured sufficiently to protect the ditch or swale unless the slope of the swale is greater than 4 percent. The area beneath the check dams shall be seeded and mulched immediately after dam removal.

Maintenance Standards

- Triangular silt dams shall be inspected for performance and sediment accumulation during and after each runoff event. Sediment shall be removed when it reaches one-half the height of the dam.
- Anticipate submergence and deposition above the triangular silt dam and erosion from high flows around the edges of the dam. Immediately repair any damage or any undercutting of the dam.

BMP C209: Outlet Protection



Purpose

Outlet protection prevents scour at conveyance outlets and minimizes the potential for downstream erosion by reducing the velocity of concentrated stormwater flows.

Conditions of Use

Outlet protection is required at the outlets of all ponds, pipes, ditches, or other conveyances, and where runoff is conveyed to a natural or artificial drainage feature such as a stream, wetland, lake, or ditch.

Design and Installation Specifications

The receiving water body or channel at the outlet of a culvert shall be protected from erosion by rock lining a minimum of 6 feet downstream and extending up the channel sides a minimum of 1 foot above the maximum tailwater elevation or 1 foot above the crown, whichever is higher. For large pipes (more than 18 inches in diameter), the outlet protection lining of the channel is lengthened to four times the diameter of the culvert.

- Standard wingwalls, and tapered outlets and paved channels should also be considered when appropriate for permanent culvert outlet protection. (See

WSDOT Hydraulics Manual, available through WSDOT Engineering Publications: <www.wsdot.wa.gov/Publications/Manuals/index.htm>.)

- Organic or synthetic erosion blankets, with or without vegetation, are usually more effective than rock, cheaper, and easier to install. Materials can be chosen using manufacturer product specifications. ASTM test results are available for most products and the designer can choose the correct material for the expected flow.
- With low flows, vegetation (including sod) can be effective.
- The following shall be used for riprap outlet protection:
 - If the discharge velocity at the outlet is less than 5 feet per second (pipe slope typically less than 10 percent), use 2-inch to 8-inch riprap. Minimum thickness is 1 foot.
 - For outlets at the base of steep slope pipes (pipe slope greater than 10 percent), an engineered energy dissipater shall be used.
- Filter fabric or erosion control blankets shall be used under riprap to prevent scour and channel erosion.
- New pipe outfalls can provide an opportunity for low-cost fish habitat improvements. For example, an alcove of low-velocity water can be created by constructing the pipe outfall and associated energy dissipater back from the stream edge and digging a channel, over-widened to the upstream side, from the outfall. Overwintering juvenile and migrating adult salmonids may use the alcove as shelter during high flows. Bank stabilization, bioengineering, and habitat features may be required for disturbed areas. This work may require an HPA permit. See Volume III for more information on outfall system design.

Maintenance Standards

- Add rock as needed to maintain the intended function.
- Clean energy dissipater if sediment builds up.

BMP C220: Storm Drain Inlet Protection***Purpose***

Storm drain inlet protection prevents coarse sediment from entering drainage systems prior to permanent stabilization of the disturbed area.

Conditions of Use

Use storm drain inlet protection at inlets that are operational before permanent stabilization of the disturbed drainage area. If these BMPs are used on active roadways, projects shall install appropriate traffic control to ensure vehicle and pedestrian traffic is not exposed to the roadway obstructions. Provide protection for all storm drain inlets downslope and within 500 feet of a disturbed or construction area, unless conveying runoff entering catch basins to a sediment pond or trap that is part of the SWPPP and will be cleaned after final stabilization.

Also use inlet protection for lawn and yard drains on new home construction. These small and numerous drains coupled with lack of gutters in new home construction can add significant amounts of sediment into the roof drain system. If possible delay installing lawn and yard drains until just before landscaping or cap these drains to prevent sediment from entering the system until completion of landscaping. Consider erosion protection methods around each finished lawn and yard drain until area is stabilized.

Table 3.11 lists several options for inlet protection. All the methods for storm drain inlet protection tend to plug and require a high frequency of maintenance. Limit drainage areas to 1 acre or less. Possibly provide emergency overflows with additional end-of-pipe treatment where stormwater ponding would cause a hazard.

Table 3.11. Storm Drain Inlet Protection.			
Type of Inlet Protection	Emergency Overflow?	Applicable for Paved or Earthen Surfaces	Conditions of Use
Drop Inlet Protection			
Excavated drop inlet protection	Yes, temporary flooding will occur	Earthen	Applicable for heavy flows; easy to maintain; large area requirement: 30x30 feet per acre
Rock socks and gravel	Yes	Paved or Earthen	Applicable for heavy concentrated flows; will not pond
Gravel and wire drop inlet protection	No		Applicable for heavy concentrated flows; will pond; can withstand traffic
Catch basin filters	Yes	Paved or Earthen	Frequent maintenance required
Curb Inlet Protection			
Curb inlet protection with a wooden weir	Small capacity overflow	Paved	Used for sturdy, more compact installation
Rock socks and gravel	Yes	Paved	Sturdy, but limited filtration
Culvert Inlet Protection			
Culvert inlet sediment trap			18-month expected life

Design and Installation Specifications

- **Excavated Drop Inlet Protection:** An excavated impoundment around the storm drain. Sediment settles out of the stormwater prior to entering the storm drain.
 - Provide a depth 1 to 2 feet as measured from the crest of the inlet structure.
 - Slope sides of excavation no steeper than 2:1.
 - Minimum volume of excavation 35 cubic yards.
 - Shape basin to fit site with longest dimension oriented toward the longest inflow area.
 - Install provisions for draining to prevent standing water problems.
 - Clear the area of all debris.
 - Grade the approach to the inlet uniformly.
 - Drill weep holes into the side of the inlet.
 - Protect weep holes with screen wire and washed aggregate.
 - Seal weep holes when removing structure and stabilizing area.
 - It may be necessary to build a temporary dike to the down slope side of the structure to prevent bypass flow.

- **Rock Sock Drop Inlet Protection:** A barrier formed around the storm drain inlet with overlapping rock socks. See Figure 3.17.

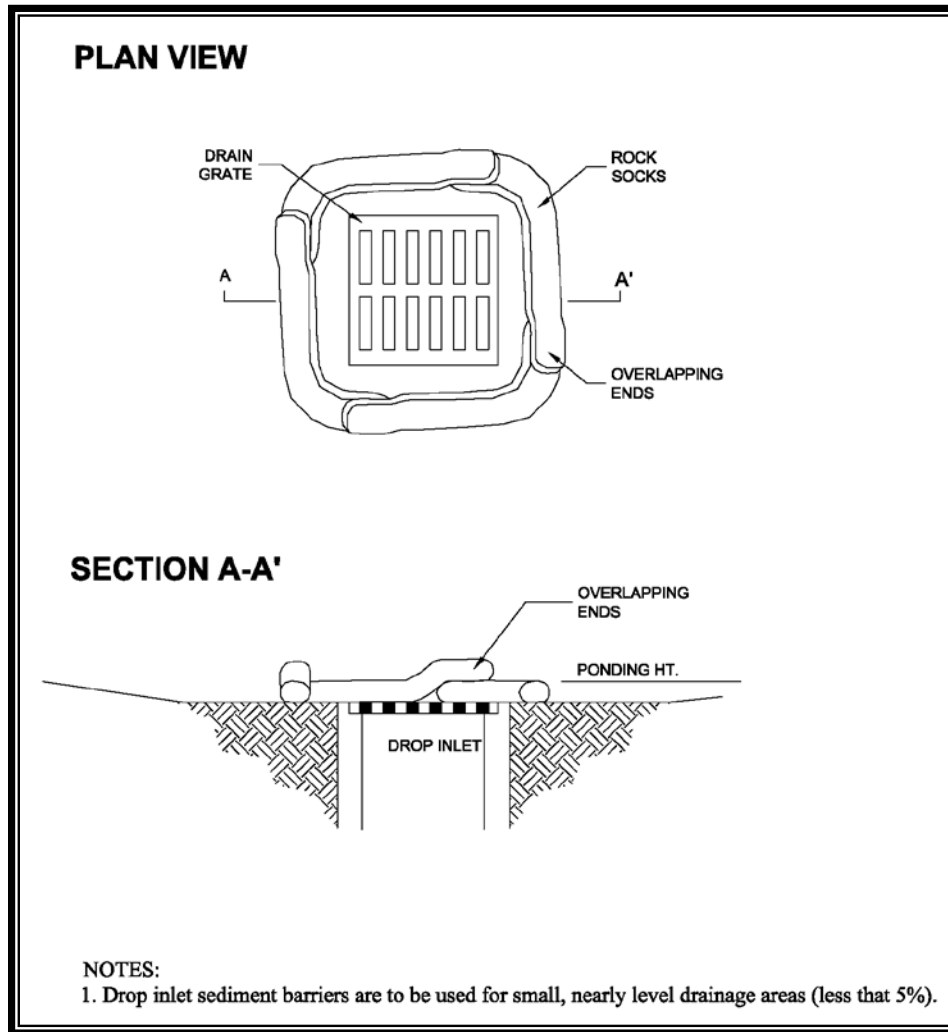

Figure 3.17. Rock Sock Drop Inlet Protection.

- Rock socks are bags made of burlap or geotextile fabric and are approximately 40 inches long and 6 inches in diameter. They are filled with 1/2-inch round rock to 24 inch length and a weight of 16 to 20 pounds.
- Use loosely woven material, such as burlap for filtration and a tight weave geotextile for diversion.
- Completely circle inlet with rock socks.
- Overlap ends to prevent gaps.
- Rock socks may be stacked if required, but should be replaced with gravel filled sandbags for large flows.

- **Gravel and Wire Mesh Filter:** A gravel barrier placed over the top of the inlet. This structure does not provide an overflow.
 - Use a hardware cloth or comparable wire mesh with 1/2-inch openings
 - Use coarse aggregate
 - Provide a height 1 foot or more, 18 inches wider than inlet on all sides
 - Place wire mesh over the drop inlet so that the wire extends a minimum of 1 foot beyond each side of the inlet structure
 - Overlap the strips if more than one strip of mesh is necessary
 - Place coarse aggregate over the wire mesh
 - Provide at least a 12-inch depth of gravel over the entire inlet opening and extend at least 18 inches on all sides.

- **Catch Basin Filters:** Use inserts designed by manufacturers for construction sites. The limited sediment storage capacity increases the amount of inspection and maintenance required, which may be daily for heavy sediment loads. To reduce maintenance requirements, combine a catch basin filter with another type of inlet protection. The combination of inlet protection and filters may provide flow bypass without overflow and therefore may be a better method for inlets located along active rights-of-way.
 - Provide 5 cubic feet of storage.
 - Requires dewatering provisions for sediment removed from the filter.
 - Provide a high-flow bypass that will not clog under normal use at a construction site.
 - Insert the catch basin filter in the catch basin just below the grating.

- **Curb Inlet Protection with Wooden Weir** – Barrier formed around a curb inlet with a wooden frame and gravel.
 - Wire mesh with 1/2-inch openings.
 - Extra strength filter cloth.
 - Construct a frame.
 - Attach the wire and filter fabric to the frame.
 - Pile coarse washed aggregate against wire/fabric.
 - Place weight on frame anchors.

- **Curb and Gutter Sediment Barrier:** Sandbag or rock berm (riprap and aggregate) 3 feet high and 3 feet wide in a horseshoe shape. See Figure 3.18.
 - Construct a horseshoe shaped berm, faced with coarse aggregate if using riprap, 3 feet high and 3 feet wide, at least 2 feet from the inlet.
 - Construct a horseshoe shaped sedimentation trap on the outside of the berm sized to sediment trap standards for protecting a culvert inlet.

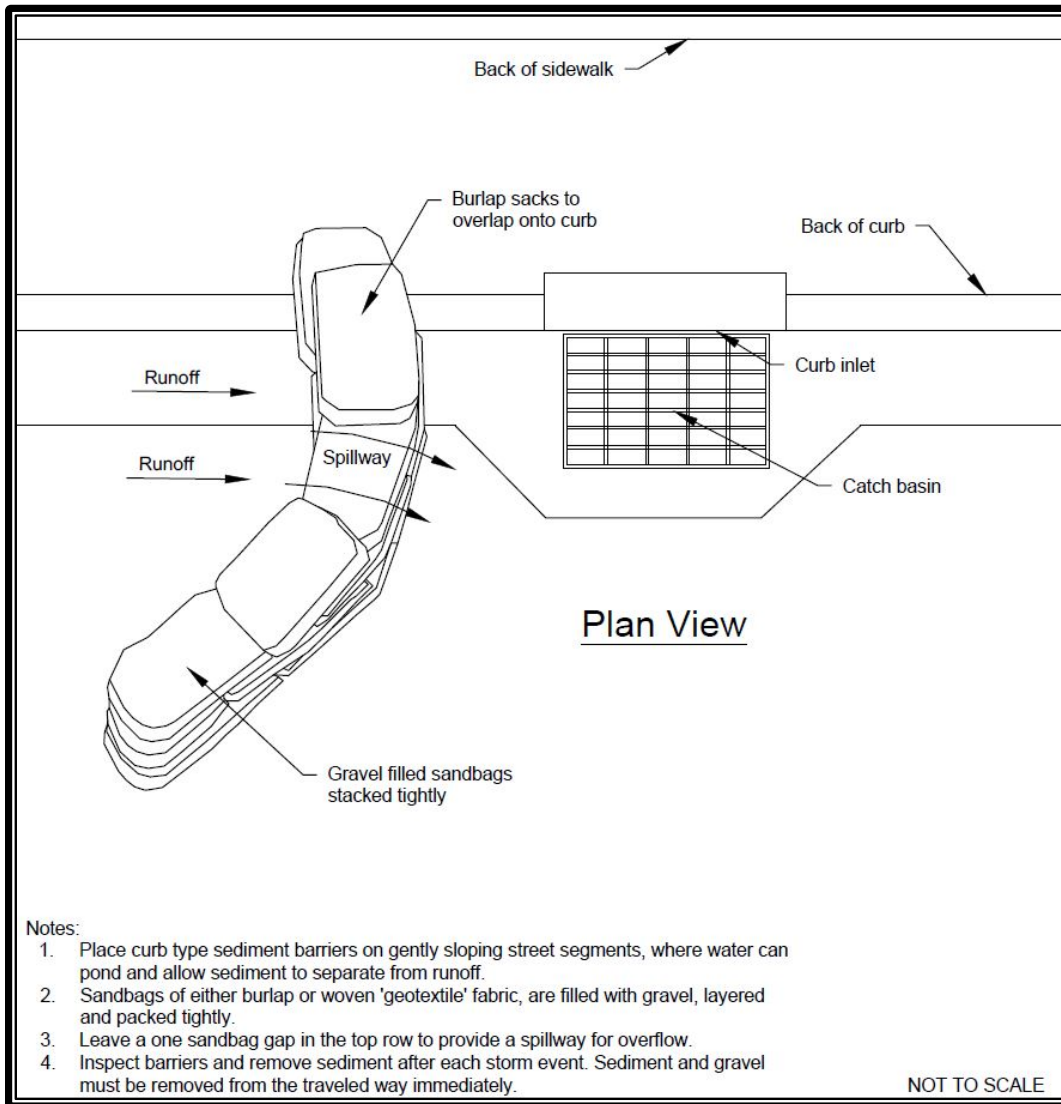

Figure 3.18. Curb and Gutter Barrier.

Maintenance Standards

- Inspect catch basin filters frequently, especially after storm events. Clean or replace clogged inserts. For systems with clogged stone filters pull away from the inlet and clean or replace. An alternative approach would be to use the clogged stone as fill and put fresh stone around the inlet.
- Do not wash sediment into storm drains while cleaning. Spread all excavated material evenly over the surrounding land area or stockpile and stabilize as appropriate.

Approved as Equivalent

Ecology has approved specific products as able to meet the requirements of BMP C220. However, the products did not pass through the TAPE process. The list of products is available on Ecology's web site at

www.ecy.wa.gov/programs/wq/stormwater/newtech/equivalent.html.

If a project wishes to use any of the "approved as equivalent" BMPs in the City of Tumwater, the project owner or representative must obtain approval for use of the BMP from the city on a case-by-case basis (i.e., for each project or site) before use.

BMP C233: Silt Fence

Purpose

Use of a silt fence reduces the transport of coarse sediment from a construction site by providing a temporary physical barrier to sediment and reducing the runoff velocities of overland flow. See Figure 3.19 for details on silt fence construction.

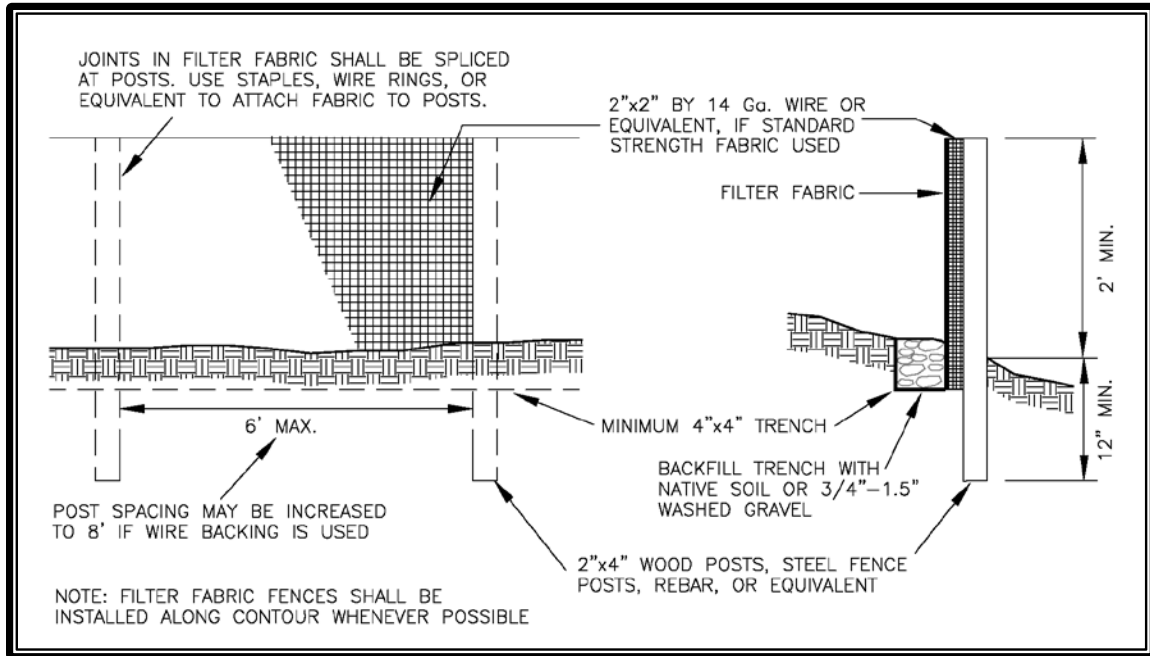

Figure 3.19. Silt Fence.

Conditions of Use

- Silt fence may be used downslope of all disturbed areas.
- Silt fence shall prevent soil carried by runoff water from going beneath, through, or over the top of the silt fence, but shall allow the water to pass through the fence.
- Silt fence is not intended to treat concentrated flows, nor is it intended to treat substantial amounts of overland flow. Convey any concentrated flows through the drainage system to a sediment pond.
- Do not construct silt fences in streams or use in V-shaped ditches. Silt fences do not provide an adequate method of silt control for anything deeper than sheet or overland flow.

Design and Installation Specifications

- Use in combination with sediment basins or other BMPs.
- Maximum slope steepness (normal [perpendicular] to fence line) 1H:1V.
- Maximum sheet or overland flowpath length to the fence of 100 feet.
- Do not allow flows greater than 0.5 cubic foot per second.
- The geotextile used shall meet the following standards. All geotextile properties listed below are minimum average roll values (i.e., the test result for any sampled roll in a lot shall meet or exceed the values shown in Table 3.12):

Table 3.12. Geotextile Minimum Standards.	
Polymeric Mesh AOS (ASTM D4751)	0.60 mm maximum for film wovens (U.S. #30 sieve). 0.30 mm maximum for all other geotextile types (U.S. #50 sieve). 0.15 mm minimum for all fabric types (U.S. #100 sieve).
Water Permittivity (ASTM D4491)	0.02 sec ⁻¹ minimum
Grab Tensile Strength (ASTM D4632)	180 lbs Minimum for extra strength fabric. 100 lbs minimum for standard strength fabric.
Grab Tensile Strength (ASTM D4632)	30% maximum
Ultraviolet Resistance (ASTM D4355)	70% minimum

- Standard strength fabrics must be supported with wire mesh, chicken wire, 2-inch by 2-inch wire, safety fence, or jute mesh to increase the strength of the fabric to the 180-pound minimum threshold. Silt fence materials are available that have synthetic mesh backing attached.
- Filter fabric material shall contain ultraviolet ray inhibitors and stabilizers to provide a minimum of 6 months of expected usable construction life at a temperature range of 0°F to 120°F.
- Include the following standard notes for silt fence on construction plans and specifications:
 - The contractor shall install and maintain temporary silt fences at the locations shown in the Plans.
 - Construct silt fences in areas of clearing, grading, or drainage prior to starting those activities.
 - The silt fence shall have a 2-foot minimum and 2.5-foot maximum height above the adjacent ground surface.
 - The filter fabric shall be sewn together at the point of manufacture to form filter fabric lengths as required. Locate all sewn seams at support posts.

Alternatively, two sections of silt fence can be overlapped, provided the contractor can demonstrate, to the satisfaction of the engineer, that the overlap is long enough and that the adjacent fence sections are close enough together to prevent silt laden water from escaping through the fence at the overlap.

- Attach the filter fabric on the upslope side of the posts and secure with staples, wire, or in accordance with the manufacturer's recommendations. Attach the filter fabric to the posts in a manner that reduces the potential for tearing.
- Support the filter fabric with wire or plastic mesh, dependent on the properties of the geotextile selected for use. If wire or plastic mesh is used, fasten the mesh securely to the upslope side of the posts with the filter fabric upslope of the mesh.
- Mesh support, if used, shall consist of steel wire with a maximum mesh spacing of 2 inches, or a prefabricated polymeric mesh. The strength of the wire or polymeric mesh shall be equivalent to or greater than 180 pounds grab tensile strength. The polymeric mesh must be as resistant to the same level of ultraviolet radiation as the filter fabric it supports.
- Bury the bottom of the filter fabric 4 inches minimum below the ground surface. Backfill and tamp soil in place over the buried portion of the filter fabric, so that no flow can pass beneath the fence and scouring cannot occur. The wire or polymeric mesh shall extend into the ground 3 inches minimum.
- Drive or place the fence posts into the ground 18 inches minimum. A 12-inch minimum depth is allowed if topsoil or other soft subgrade soil is not present and 18 inches cannot be reached. Increase fence post min. depths by 6 inches if the fence is located on slopes of 3H:1V or steeper and the slope is perpendicular to the fence. If required post depths cannot be obtained, the posts shall be adequately secured by bracing or guying to prevent overturning of the fence due to sediment loading.
- Use wood, steel, or equivalent posts. The spacing of the support posts shall be a maximum of 6 feet. Posts shall consist of either:
 - Wood with dimensions of 2-inch by 2-inch minimum width and a 3-foot minimum length. Wood posts shall be free of defects such as knots, splits, or gouges.
 - No. 6 steel reinforcement bar or larger.
 - ASTM A 120 steel pipe with a minimum diameter of 1 inch.
 - U, T, L, or C shape steel posts with a minimum weight of 1.35 pounds per foot.
 - Other steel posts having equivalent strength and bending resistance to the post sizes listed above.

- Locate silt fences on contour as much as possible, except at the ends of the fence, where the fence shall be turned uphill such that the silt fence captures the runoff water and prevents water from flowing around the end of the fence.
- If the fence must cross contours, with the exception of the ends of the fence, gravel check dams shall be placed perpendicular to the back of the fence to minimize concentrated flow and erosion. The slope of the fence line where contours must be crossed shall not be steeper than 3H:1V.
 - Gravel check dams shall be approximately 1 foot deep at the back of the fence. Gravel check dams shall be continued perpendicular to the fence at the same elevation until the top of the check dam intercepts the ground surface behind the fence.
 - Gravel check dams shall consist of crushed surfacing base course, gravel backfill for walls, or shoulder ballast. Gravel check dams shall be located every 10 feet along the fence where the fence must cross contours.
- Silt fence installation using the slicing method specification details follow. See also Figure 3.20.
 - The base of both end posts must be at least 2 to 4 inches above the top of the filter fabric on the middle posts for ditch check dams to drain properly. Use a hand level or string level, if necessary, to mark base points before installation.
 - Install posts 3 to 4 feet apart in critical retention areas and 6 to 7 feet apart in standard applications. Install posts 24 inches deep on the downstream side of the silt fence, and as close as possible to the filter fabric, enabling posts to support the filter fabric from upstream water pressure.
 - Install posts with the nipples facing away from the filter fabric.
 - Attach the filter fabric to each post with three ties, all spaced within the top 8 inches of the filter fabric. Attach each tie diagonally 45 degrees through the filter fabric, with each puncture at least 1 inch vertically apart. Each tie should be positioned to hang on a post nipple when tightening to prevent sagging.
 - Wrap approximately 6 inches of fabric around the end posts and secure with three ties.
 - No more than 24 inches of a 36-inch filter fabric is allowed above ground level, 12 inches must be buried.
 - Compact the soil immediately next to the filter fabric with the front wheel of the tractor, skid steer, or roller exerting at least 60 pounds per square inch. Compact the upstream side first and then each side twice for a total of four trips. Check and correct the silt fence installation for any deviation before compaction. Use a flat-bladed shovel to tuck fabric deeper into the ground if necessary.

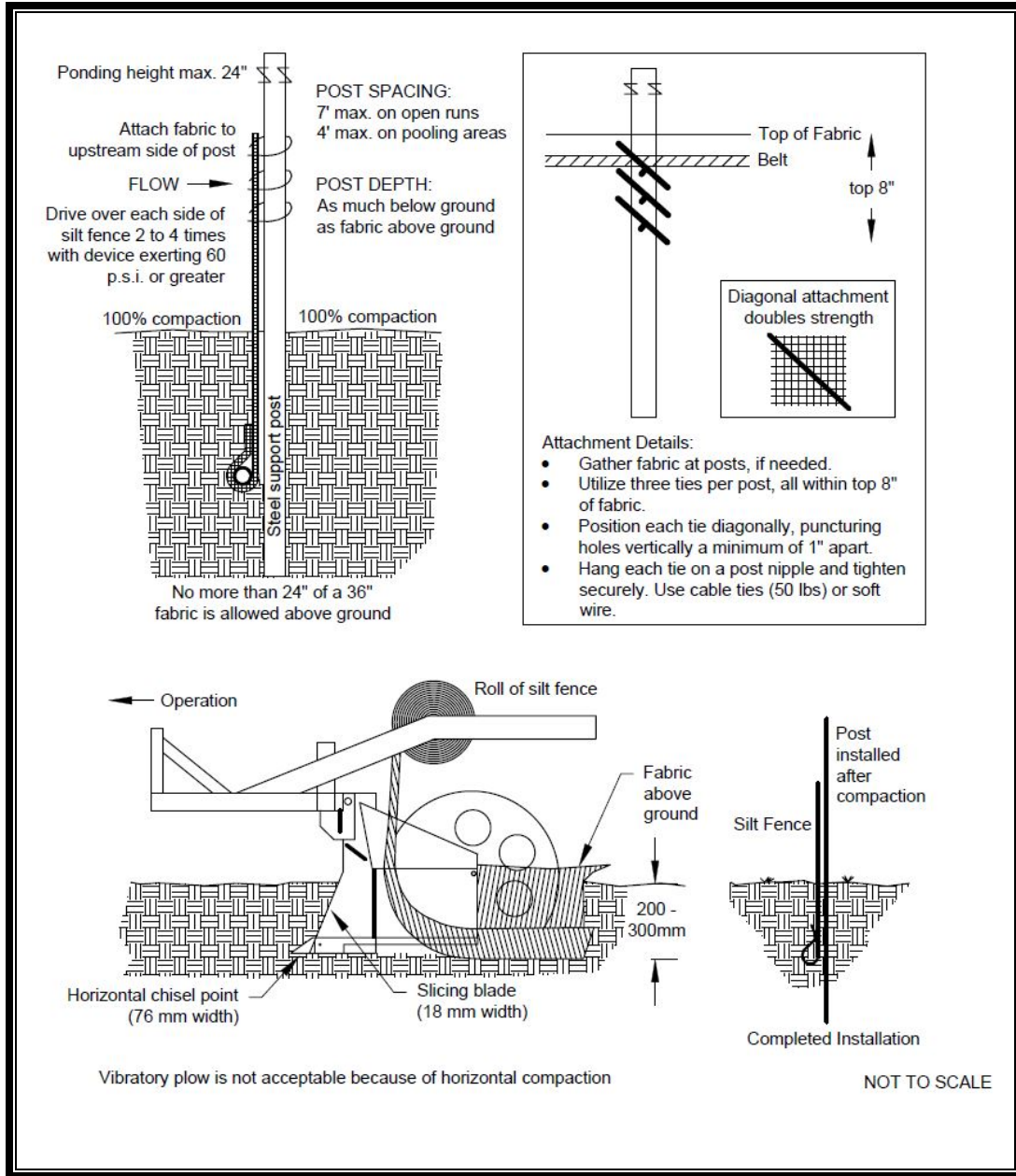

Figure 3.20. Silt Fence Installation by Slicing Method.

Maintenance Standards

- Repair any damage immediately.
- Intercept and convey all evident concentrated flows uphill of the fence to a sediment pond.
- Check the uphill side of the fence for signs of the fence clogging and acting as a barrier to flow and then causing channelization of flows parallel to the fence. If this occurs, replace the fence or remove the trapped sediment.

- Remove sediment deposits when the deposit reaches approximately one-third the height of the silt fence, or install a second silt fence.
- Replace filter fabric that has deteriorated due to ultraviolet breakdown.

C234: Vegetated Strip

Purpose

Vegetated strips reduce the transport of coarse sediment from a construction site by providing a temporary physical barrier to sediment and reducing the runoff velocities of overland flow.

Conditions of Use

- Vegetated strips may be used downslope of disturbed areas.
- Vegetated strips are not intended to treat concentrated flows, nor are they intended to treat substantial amounts of overland flow. Any concentrated flows must be conveyed through the drainage system to a sediment pond. The only circumstance in which overland flow can be treated solely by a strip, rather than by a sediment pond, is when the criteria in Table 3.13 are met.

Table 3.13. Vegetated Strips.		
Average Contributing Area Slope	Average Contributing Area Percent Slope	Maximum Contributing Area Flowpath Length
1.5H:1V or flatter	67% or flatter	100 feet
2H:1V or flatter	50% or flatter	115 feet
4H:1V or flatter	25% or flatter	150 feet
6H:1V or flatter	16.7% or flatter	200 feet
10H:1V or flatter	10% or flatter	250 feet

Design and Installation Specifications

- The vegetated strip shall consist of a continuous strip of dense vegetation with topsoil and have a minimum 25-foot-long flowpath. Grass-covered, landscaped areas are generally not adequate because the volume of sediment overwhelms the grass. Ideally, vegetated strips should consist of undisturbed native growth with a well-developed soil that allows for infiltration of runoff.
- The slope within the strip shall not exceed 4H:1V.
- The uphill boundary of the vegetated strip shall be delineated with clearing limits.

Maintenance Standards

- Any areas damaged by erosion or construction activity shall be seeded immediately and protected by mulch.
- If more than 5 feet of the original vegetated strip width has had vegetation removed or is being eroded, sod must be installed.
- If there are indications that concentrated flows are traveling across the buffer, surface water controls must be installed to reduce the flows entering the buffer, or additional perimeter protection must be installed.

BMP C235: Wattles***Purpose***

Wattles are temporary erosion and sediment control barriers consisting of straw, compost, or other material that is wrapped in biodegradable tubular plastic or similar encasing material. They reduce the velocity and can spread the flow of rill and sheet runoff, and can capture and retain sediment. Wattles are typically 8 to 10 inches in diameter and 25 to 30 feet in length. Wattles are placed in shallow trenches and staked along the contour of disturbed or newly constructed slopes. See Figure 3.21 for typical construction details.

Conditions of Use

- Use wattles:
 - In disturbed areas that require immediate erosion protection.
 - On exposed soils during the period of short construction delays, or over winter months
 - On slopes requiring stabilization until permanent vegetation can be established.
- The material used dictates the effectiveness period of the wattle. Typically, wattles are effective for one to two wet seasons.
- Prevent rilling beneath wattles by properly entrenching and abutting wattles together to prevent water from passing between them.

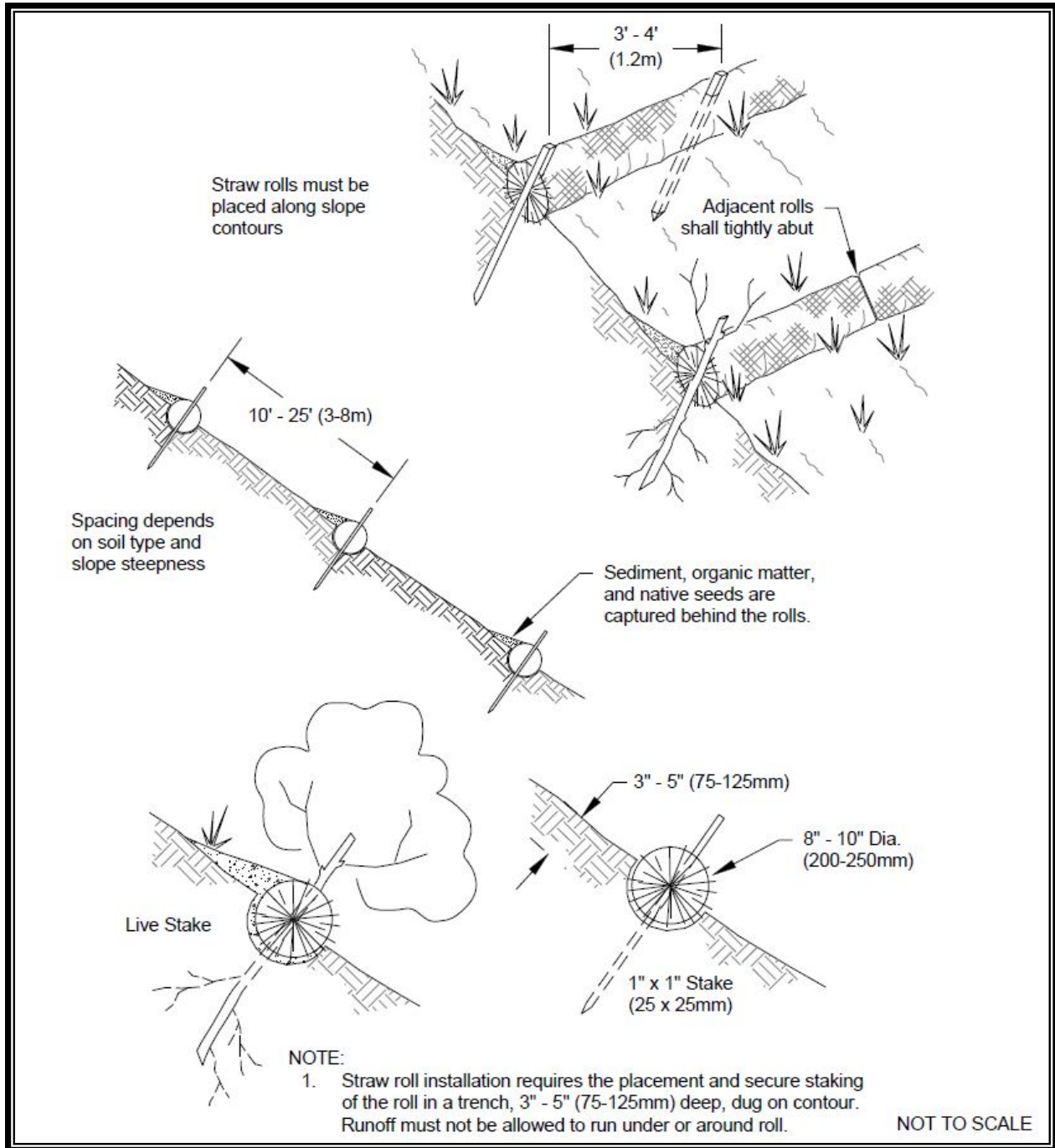

Figure 3.21. Straw Wattles.

Design Criteria

- Install wattles perpendicular to the flow direction and parallel to the slope contour.
- Narrow trenches shall be dug across the slope on contour to a depth of 3 to 5 inches on clay soils and soils with gradual slopes. On loose soils, steep slopes, and areas with high rainfall, the trenches shall be dug to a depth of 5 to 7 inches, or one-half to two-thirds of the thickness of the wattle.
- Start building trenches and installing wattles from the base of the slope and work up. Spread excavated material evenly along the uphill slope and compact using hand tamping or other methods.
- Construct trenches on contours at intervals of 10 to 25 feet apart depending on the steepness of the slope, soil type, and rainfall. The steeper the slope the closer together the trenches.
- Install the wattles snugly into the trenches and abut tightly end to end. Do not overlap the ends.
- Install stakes at each end of the wattle, and at 4-foot centers along entire length of wattle.
- If required, install pilot holes for the stakes using a straight bar to drive holes through the wattle and into the soil.
- Wooden stakes should be approximately 0.75 by 0.75 by 24 inches minimum. Willow cuttings or 0.375-inch rebar can also be used for stakes. Note: rebar must be removed at end of project if used, while other fasteners maybe permitted to remain if all parts of the wattles are biodegradable and shown in plans for permanent erosion control.
- Stakes should be driven through the middle of the wattle, leaving 2 to 3 inches of the stake protruding above the wattle.

Maintenance Standards

- Wattles may require maintenance to ensure they are in contact with soil and thoroughly entrenched, especially after significant rainfall on steep sandy soils.
- Inspect the slope after significant storms and repair any areas where wattles are not tightly abutted or water has scoured beneath the wattles.

Approved as Equivalent

Ecology has approved specific products as able to meet the requirements of BMP C235. However, the products did not pass through the TAPE process. The list of products is available on Ecology's web site at

<www.ecy.wa.gov/programs/wq/stormwater/newtech/equivalent.html>.

If a project wishes to use any of the “approved as equivalent” BMPs in the City of Tumwater, the project owner or representative must obtain approval for use of the BMP from the city on a case-by-case basis (i.e., for each project or site) before use.

BMP C236: Vegetative Filtration

Purpose

Vegetative filtration may be used in conjunction with BMP C241: Temporary Sediment Ponds, BMP C206: Level Spreader, and a pumping system with surface intake to improve turbidity levels of stormwater discharges by filtering through existing vegetation where undisturbed forest floor duff layer or established lawn with thatch layer are present. Vegetative filtration can also be used to infiltrate dewatering waste from foundations, vaults, and trenches as long as runoff does not occur.

Conditions of Use

- For every 5 acres of disturbed soil, use 1 acre of grass field, farm pasture, or wooded area. Reduce or increase this area depending on project size, groundwater table height, and other site conditions.
- Wetlands shall not be used for filtration.
- Do not use this BMP in areas with a high groundwater table, or in areas that will have groundwater within 1 foot of the surface during the use of this BMP.
- This BMP may be less effective on soils that prevent the infiltration of the water, such as hard till.
- The soils within the vegetative filtration area must meet the site characterization and site suitability criteria for providing water quality treatment (see Volume V, Section 23.3).
- Stop distributing water into the vegetated area if standing water or erosion results.
- When feasible, acquire additional area to provide a redundant location for this BMP in the event that the first area becomes saturated or infiltration is reduced.

Design Criteria

- Site must have access to a sufficient area that has a vegetated field, preferably a farm field, or wooded area, either on the project site or on a neighboring site, which will remain undisturbed during the entire course of use as a BMP, and provide a 5:1 ratio of vegetative filtration area to construction site area
- An easement is required for any off-site area used to meet the requirements of this BMP. If the project site does not contain enough vegetated field area consider obtaining easement from adjacent landowners if conditions would allow for proper filtration.

Flow and Distribution Options

- Install a distribution line and a manifold, if needed.
 - A pump may be added, if the water cannot gravity flow to the vegetated area, if sprinkler heads are used, or if pressure is needed for even distribution of flow.
 - The manifold should have several valves, allowing for control over the distribution area in the field.
 - Generally, the main distribution line should reach the vegetative filtration area and span across the site, and branches shall be provided to adequately spread the water across the area. Many large projects, or projects on tight soil, will require systems that reach several thousand feet long with numerous branch lines off the main distribution line. See the estimated flowpath length guidelines in Table 3.14. These may be used as guidelines to determine branch spacing on slopes. Adjust branch spacing as needed to achieve desired performance.

Table 3.14. Flowpath Guidelines for Vegetative Filtration.		
Average Slope	Average Area Slope (percent)	Estimated Flowpath Length (feet)
4H:1V	25%	150
6H:1V	16.7%	115
10H:1V	10%	100

- Install adequate type and size of pipe or hose to convey the turbid water to the vegetative filtration area and distribute the water evenly across the area. See Figure 3.22.
- Determine the branch length based on the size of the vegetative filtration area and number of branches. Typically, branches stretch from 200 feet to several thousand feet. Always, lay branches on contour with the slope.

Dispersal Component Options

- On uneven ground, sprinklers perform well. Space sprinkler heads so that spray patterns do not overlap.
- On relatively even surfaces, a level spreader using 4-inch perforated pipe may be used as an alternative option to the sprinkler head setup. Install drain pipe at the highest point on the field and at various lower elevations to ensure full coverage of the vegetative filtration area. Pipe should be placed with the holes up to allow for a gentle weeping of stormwater evenly out all holes. Leveling the pipe by staking and using sandbags may be required.

- To prevent the over saturation of the field area, rotate the use of branches or spray heads. Do this as needed based on monitoring the spray field.



Figure 3.22. Manifold and Branches in a Wooded Vegetative Filtration Area.

Maintenance Standards

- Monitor the vegetative filtration area three to five times per day to ensure that overland flow is not causing a water quality violation, not causing over saturation of any portion of the field, and not causing erosion. Monitor three to five times per day to ensure that any flow into waters of the State does not exceed water quality standards for turbidity.
- The presence of standing puddles of water or creation of concentrated flows visually signify that over saturation of the field has occurred.
- Inspect the spray nozzles daily, at a minimum, for leaks and plugging from sediment particles.
- Check all branches and the manifold for unintended leaks.
- Since the operator is handling contaminated water, physically monitor the vegetated spray field all the way down to the nearest surface water, or furthest spray area, to ensure that the water has not caused overland or concentrated flows, and has not created erosion around the spray nozzle.

- If erosion, concentrated flows, or over saturation of the field occurs, rotate the use of branches or spray heads or relocate the operation to a new location.
- The city requires that a separate “Vegetative Filtration Logbook” log be developed, maintained, and kept with the existing site logbook to aid the operator conducting inspections. This separate logbook can also aid the facility in demonstrating compliance with permit conditions.

BMP C240: Sediment Trap

Purpose

A sediment trap is a small temporary ponding area with a gravel outlet used to collect and store sediment from sites cleared and/or graded during construction.

Sediment traps, along with other perimeter controls, shall be installed before any land disturbance takes place in the drainage area.

Conditions of Use

Prior to leaving a construction site, stormwater runoff must pass through a sediment pond or trap or other appropriate sediment removal BMP. Non-engineered sediment traps may be used on site upstream to an engineered sediment trap or sediment pond to provide additional sediment removal capacity.

It is intended for use on sites where the tributary drainage area is less than 3 acres, with no unusual drainage features, and a projected build-out time of 6 months or less. The sediment trap is a temporary measure (with a design life of approximately 6 months) and shall be maintained until the site area is permanently protected against erosion by vegetation and/or structures. Remove all sediment from the trap as needed to restore function during the course of the project.

Sediment traps are only effective in removing sediment down to about the medium silt size fraction. Runoff with sediment of finer grades (fine silt and clay) will pass through untreated, emphasizing the need to control erosion to the maximum extent first.

Whenever possible, sediment-laden water shall be discharged on site, into relatively level, vegetated areas (see BMP C234: Vegetated Strip). This is the only way to effectively remove fine particles from runoff unless chemical treatment or filtration is used. This can be particularly useful after initial treatment in a sediment trap. The areas of release must be evaluated on a site-by-site basis to determine appropriate locations for and methods of releasing runoff. Vegetated wetlands shall not be used for this purpose. Frequently, it may be possible to pump water from the collection point at the downhill end of the site to an upslope vegetated area. Pumping shall only augment the treatment system, not replace it, because of the possibility of pump failure or runoff volume in excess of pump capacity.

All projects that are constructing permanent detention facilities or infiltration basins and trenches can use the rough-graded permanent facilities for traps. If infiltration facilities are to be used, the sides and bottom of the facility must only be rough excavated to a minimum of 2 feet above final grade. Final grading of the infiltration facility shall occur only when all contributing drainage areas are fully stabilized. When permanent facilities are used as temporary sedimentation facilities, the surface area requirement of a sediment trap or pond must be met. If the surface area requirements are larger than the surface area of the permanent facility, then the trap or pond shall be enlarged to comply with the

surface area requirement. The permanent pond shall also be divided into two cells as required for sediment ponds.

Either a permanent control structure or the temporary control structure (described in BMP C241: Temporary Sediment Pond) can be used. If a permanent control structure is used, it may be advisable to partially restrict the lower orifice with gravel to increase residence time while still allowing dewatering of the pond. A shut-off valve may be added to the control structure to allow complete retention of stormwater in emergency situations. In this case, an emergency overflow weir must be added.

A skimmer may be used for the sediment trap outlet if approved by the city.

Design and Installation Specifications

- See Figures 3.23 and 3.24 for details.
- If permanent runoff control facilities are part of the project, they should be used for sediment retention.

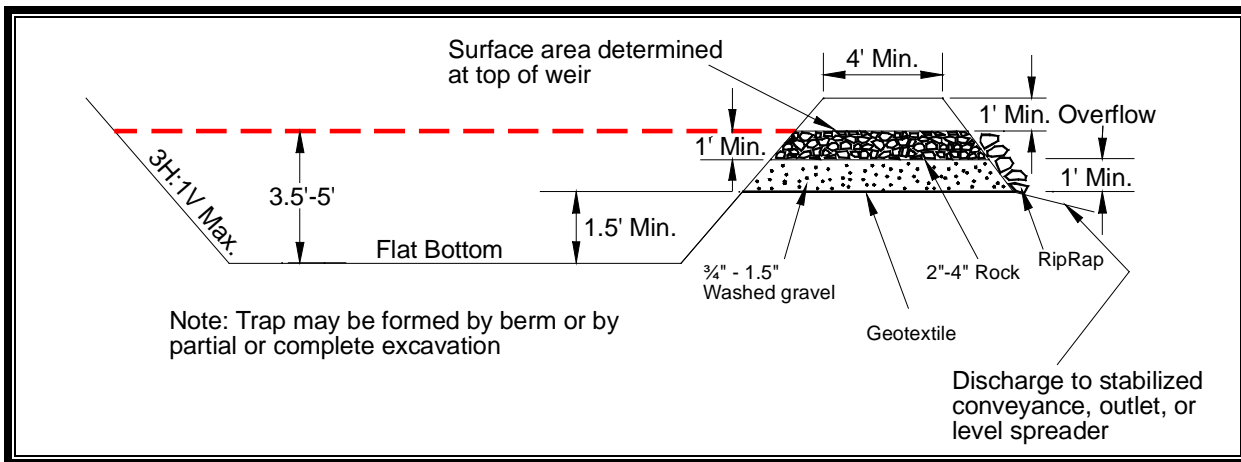

Figure 3.23. Cross-Section of Sediment Trap.

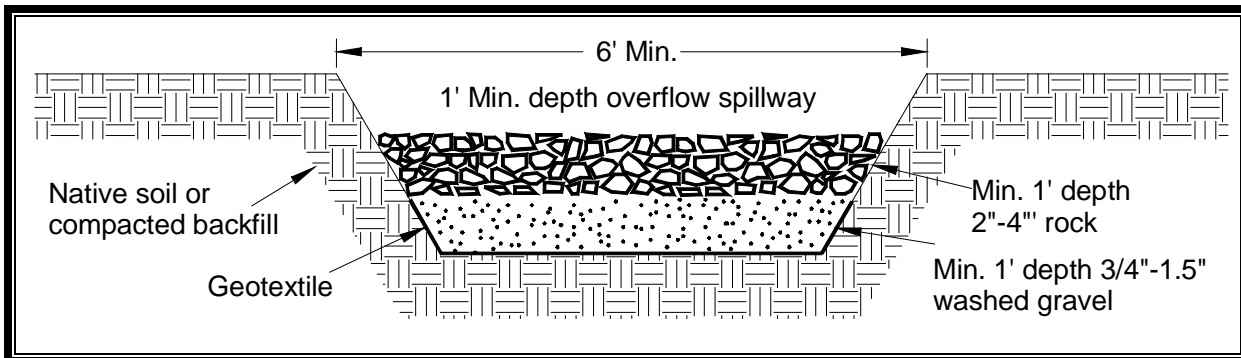

Figure 3.24. Sediment Trap Outlet.

- To determine the sediment trap geometry, first calculate the design surface area (SA) of the trap, measured at the invert of the weir. Use the following equation:

$$SA = FS(Q_2/V_s)$$

Where:

Q_2 = Design inflow (cubic feet per second) based on the 2-year recurrence interval flow rate. Use a 15-minute time step using an approved continuous runoff model for the developed (unmitigated) site. If the time of concentration is less than 30 minutes, a 5-minute time step may be required. The 10-year recurrence interval peak flow shall be used if the project size, expected timing and duration of construction, or downstream conditions warrant a higher level of protection. If no hydrologic analysis is required, the rational method may be used.

V_s = The settling velocity of the soil particle of interest. The 0.02 mm (medium silt) particle with an assumed density of 2.65 g/cm³ has been selected as the particle of interest and has a settling velocity (V_s) of 0.00096 foot per second.

FS = A factor of safety of 2 to account for non-ideal settling.

Therefore, the equation for computing surface area becomes:

$$SA = 2 \times Q_2 / 0.00096$$

OR

2,080 square feet per cubic feet per second of inflow

Note: Even if permanent facilities are used, they must still have a surface area that is at least as large as that derived from the above formula. If they do not, the pond must be enlarged.

- To aid in determining sediment depth, all sediment traps shall have a staff gauge with a prominent labeled mark each 1-foot interval above the bottom of the trap.
- Sediment traps may not be feasible on utility projects due to the limited work space or the short-term nature of the work. Portable tanks may be used in place of sediment traps for utility projects.

Maintenance Standards

- Sediment shall be removed from the trap when it reaches 1 foot in depth.
- Any damage to the trap embankments or slopes shall be repaired.

BMP C241: Temporary Sediment Pond

Purpose

Sediment ponds remove sediment from runoff originating from disturbed areas of the site.

Sediment ponds are typically designed to remove sediment no smaller than medium silt (0.02 mm). Consequently, they usually reduce turbidity only slightly and additional BMPs may be needed to treat the water prior to discharge.

Conditions of Use

Prior to leaving a construction site, stormwater runoff must pass through a sediment pond or other appropriate sediment removal BMP.

A sediment pond shall be used where the contributing drainage area is 3 acres or more. Ponds must be used in conjunction with erosion control practices to reduce the amount of sediment flowing into the basin.

Design and Installation Specifications

- Sediment ponds must be installed only on sites where failure of the structure would not result in loss of life, damage to homes or buildings, or interruption of use or service of public roads or utilities. Also, sediment traps and ponds are attractive to children and can be very dangerous. If fencing of the pond is planned, the type of fence and its location shall be shown on the Construction SWPPP.
- Structures having a maximum storage capacity at the top of the dam of 10 acre-feet (435,600 cubic feet) or more are subject to the Washington Dam Safety Regulations (Chapter 173-175 WAC).
- Projects that are constructing permanent detention facilities or infiltration basins and trenches can use the rough-graded permanent facilities for traps. The surface area requirements of the sediment pond must be met. This may require temporarily enlarging the permanent basin to comply with the surface area requirements. The permanent control structure must be temporarily replaced with a control structure that only allows water to leave the pond from the surface or by pumping. The permanent control structure must be installed after the site is fully stabilized.
- Use of infiltration facilities for sedimentation ponds during construction tends to clog the soils and reduce their capacity to infiltrate. If infiltration facilities are to be used, the sides and bottom of the facility must only be rough excavated to a minimum of 2 feet above final grade. Final grading of the infiltration facility shall occur only when all contributing drainage areas are fully stabilized. The infiltration pretreatment facility should be fully constructed and used with the sedimentation pond to help prevent clogging.

- See Figures 3.25, 3.26, and 3.27 for details.

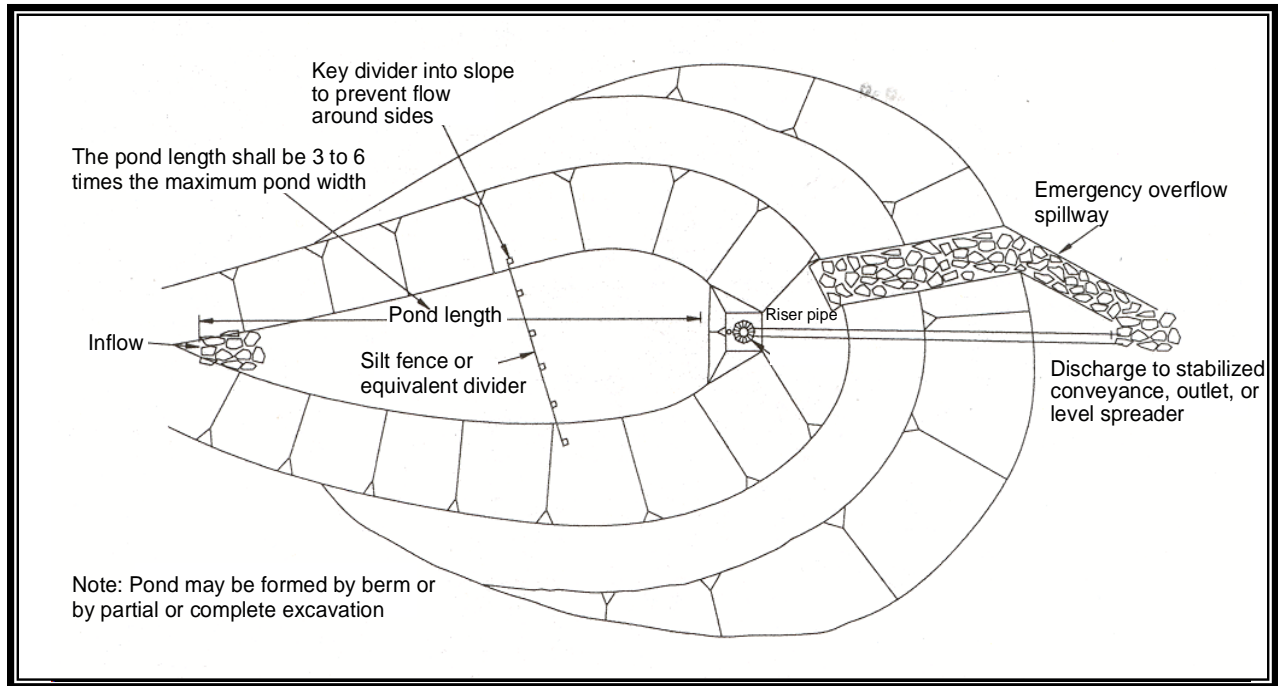

Figure 3.25. Sediment Pond Plan View.

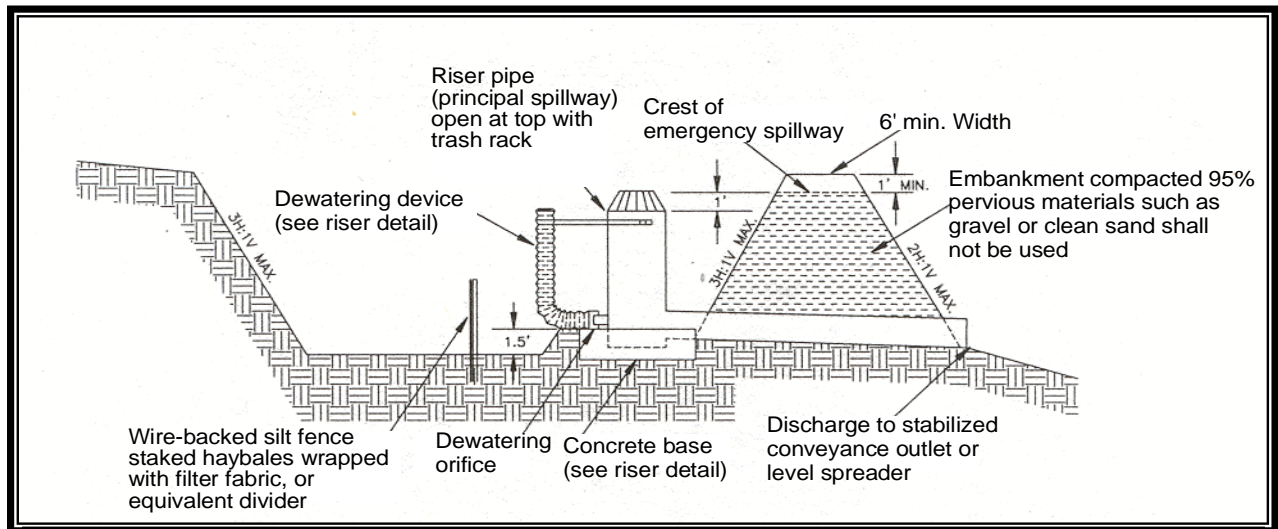

Figure 3.26. Sediment Pond Cross-Section.

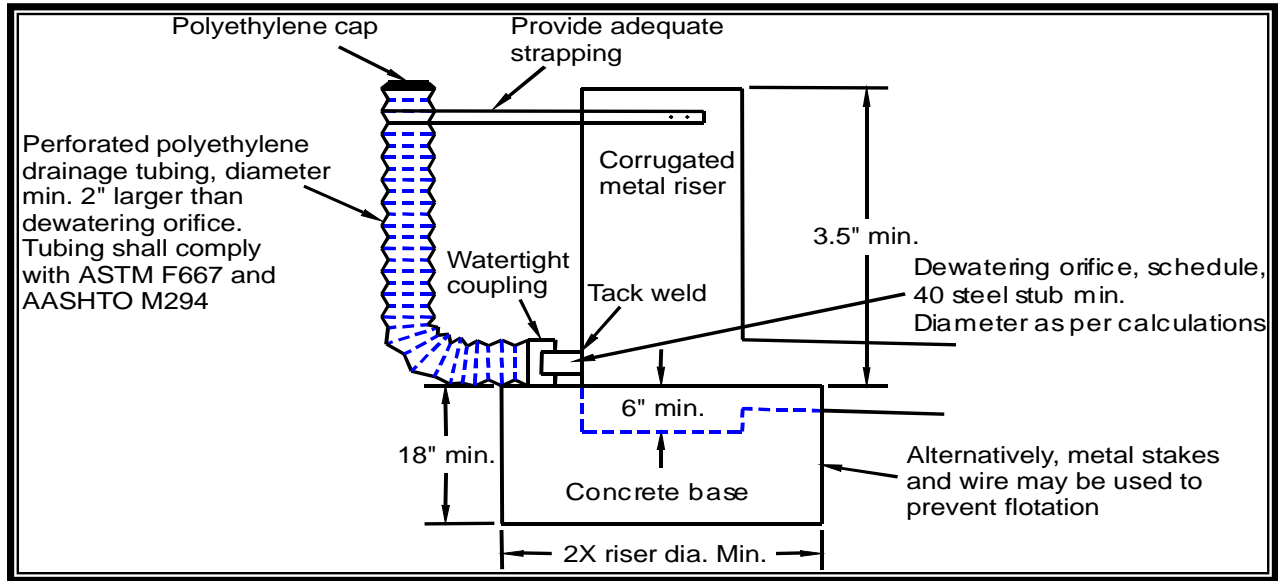

Figure 3.27. Sediment Pond Riser Detail.

Determining Pond Geometry

- Obtain the discharge from the hydrologic calculations of the peak flow for the 2-year recurrence interval runoff event (Q_2). Use a 15-minute time step and an approved continuous runoff model for the developed (unmitigated) site. If the time of concentration is less than 30 minutes, a 5-minute time step may be required. The 10-year recurrence interval peak flow shall be used if the project size, expected timing and duration of construction, or downstream conditions warrant a higher level of protection. If no hydrologic analysis is required, the Rational Method may be used.
- Determine the required surface area at the top of the riser pipe with the equation:

$$SA = 2 \times Q_2 / 0.00096$$

OR

2,080 square feet per cubic feet per second of inflow

- See BMP C240 for more information on the derivation of the surface area calculation.
- The basic geometry of the pond can now be determined using the following design criteria:
 - Required surface area SA (from Step 2 above) at top of riser.
 - Minimum 3.5-foot depth from top of riser to bottom of pond.

- Maximum 3H:1V interior side slopes and maximum 2H:1V exterior slopes. The interior slopes can be increased to a maximum of 2H:1V if fencing is provided at or above the maximum water surface.
- One foot of freeboard between the top of the riser and the crest of the emergency spillway.
- Flat bottom.
- Minimum 1-foot deep spillway.
- Length-to-width ratio between 3:1 and 6:1.

Sizing of Discharge Mechanisms

- The outlet for the pond consists of a combination of principal and emergency spillways. These outlets must pass the peak runoff expected from the contributing drainage area for a 100-year recurrence interval storm. If, due to site conditions and pond geometry, a separate emergency spillway is not feasible, the principal spillway must pass the entire peak runoff expected from the 100-year recurrence interval storm. However, an attempt to provide a separate emergency spillway should always be made. The runoff calculations should be based on the site conditions during construction. The flow through the dewatering orifice cannot be utilized when calculating the 100-year recurrence interval storm elevation because of its potential to become clogged; therefore, available spillway storage must begin at the principal spillway riser crest.
- The principal spillway designed by the procedures contained in this standard will result in some reduction in the peak rate of runoff. However, the riser outlet design will not adequately control the pond discharge to the predevelopment discharge limitations as stated in Minimum Requirement #7: Flow Control. However, if the basin for a permanent stormwater detention pond is used for a temporary sedimentation pond, the control structure for the permanent pond can be used to maintain predevelopment discharge limitations. The size of the pond, the expected life of the construction project, the anticipated downstream effects and the anticipated weather conditions during construction, should be considered to determine the need of additional discharge control. See Figure 3.28 for riser inflow curves.
 - **Principal Spillway:** Determine the required diameter for the principal spillway (riser pipe). The diameter shall be the minimum necessary to pass the discharge from the 10-year recurrence interval runoff event (Q_{10}). Use a 15-minute time step and an approved continuous runoff model for the developed (unmitigated) site. If the time of concentration is less than 30 minutes, a 5-minute time step may be required. The 10-year recurrence interval peak flow shall be used if the project size, expected timing and duration of construction, or downstream conditions warrant a higher level of

protection. If no hydrologic analysis is required, the Rational Method may be used. Use Figure 3.28 to determine this diameter ($h = 1$ -foot). Note: A permanent control structure may be used instead of a temporary riser.

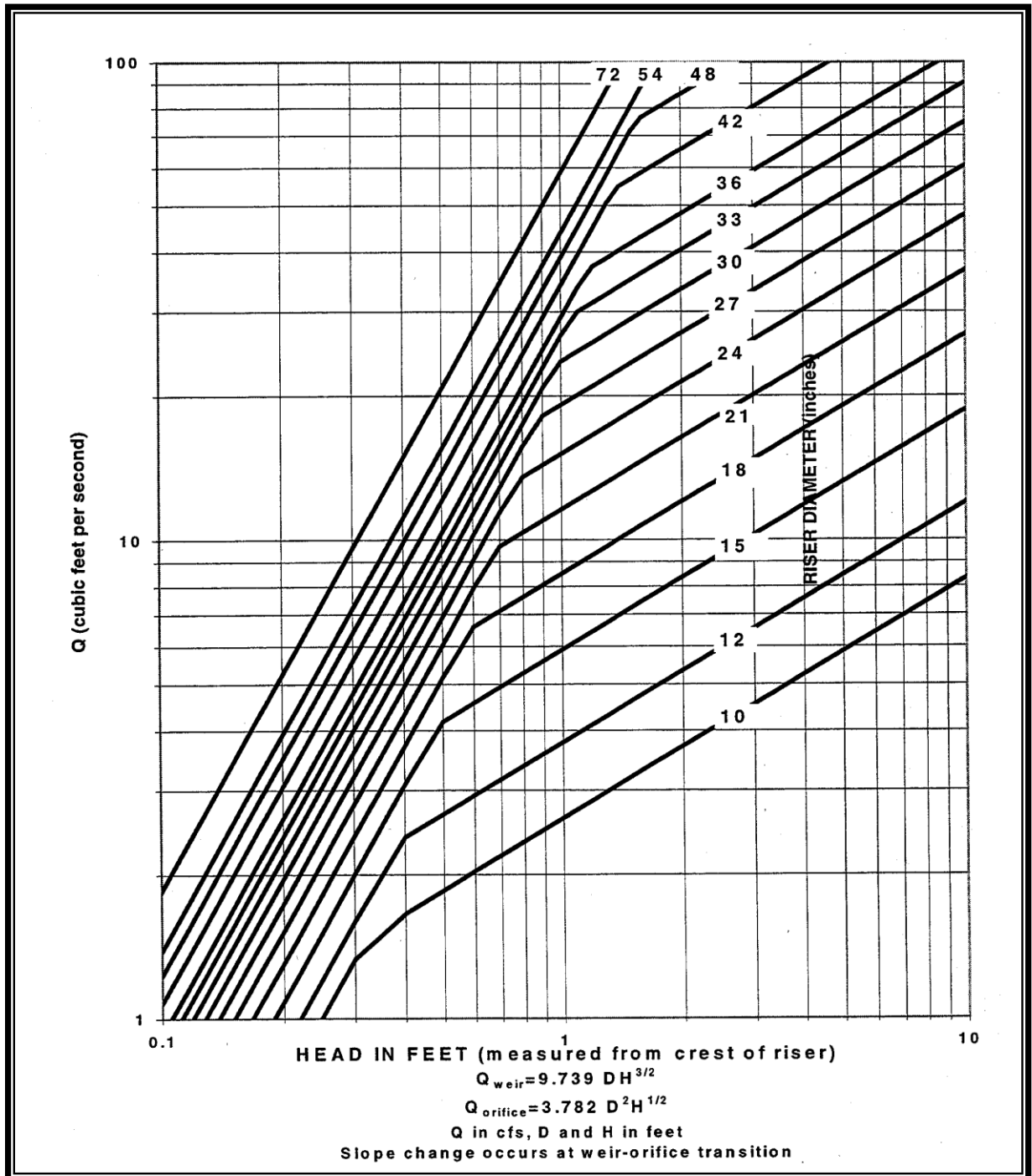

Figure 3.28. Riser Inflow Curves.

- **Emergency Overflow Spillway:** Determine the required size and design of the emergency overflow spillway for the developed 100-year peak flow indicated by an approved continuous runoff model using a 15-minute time step.
- **Dewatering Orifice:** Determine the size of the dewatering orifice(s) (minimum 1-inch diameter) using a modified version of the discharge equation for a vertical orifice and a basic equation for the area of a circular orifice. Determine the required area of the orifice with the following equation:

$$A_o = \frac{A_s (2h)^{0.5}}{0.6 \times 3600 T g^{0.5}}$$

Where: A_o = orifice area (square feet)
 A_s = pond surface area (square feet)
 h = head of water above orifice (height of riser in feet)
 T = dewatering time (24 hours)
 g = acceleration of gravity (32.2 feet/second²)

Convert the required surface area to the required diameter D of the orifice:

$$D = 24 \times \sqrt{\frac{A_o}{\pi}} = 13.54 \times \sqrt{A_o}$$

The vertical, perforated tubing connected to the dewatering orifice must be at least 2 inches larger in diameter than the orifice to improve flow characteristics. The size and number of perforations in the tubing should be large enough so that the tubing does not restrict flow. The orifice should control the flow rate.

Additional Design Specifications

The **pond shall be divided** into two roughly equal volume cells by a permeable divider that will reduce turbulence while allowing movement of water between cells. The divider shall be at least one-half the height of the riser and a minimum of 1 foot below the top of the riser. Wire-backed, 2- to 3-foot high, extra strength filter fabric supported by treated 4- by 4-inch posts can be used as a divider. If the pond is more than 6 feet deep, a different mechanism must be proposed. A riprap embankment is one acceptable method of separation for deeper ponds. Other designs that satisfy the intent of this provision are allowed, as long as the divider is permeable, structurally sound, and designed to prevent erosion under or around the barrier.

To aid in determining sediment depth, **1-foot intervals** above the pond bottom shall be prominently marked on the riser or a staff gauge.

If an **embankment** of more than 6 feet is proposed, the pond must comply with the criteria contained in Volume V regarding dam safety for detention BMPs. An electronic version of the Dam Safety Guidelines is available at

www.ecy.wa.gov/programs/wr/dams/GuidanceDocs.html.

- The most common structural failure of sedimentation ponds is caused by piping. Piping refers to two phenomena: 1) water seeping through fine-grained soil, eroding the soil grain by grain and forming pipes or tunnels; and 2) water under pressure flowing upward through a granular soil with a head of sufficient magnitude to cause soil grains to lose contact and capability for support.
- The most critical construction sequences to prevent piping will be:
 - Tight connections between riser and barrel and other pipe connections
 - Adequate anchoring of riser
 - Proper soil compaction of the embankment and riser footing
 - Proper construction of anti-seep devices

Maintenance Standards

- Sediment shall be removed from the pond when it reaches 1 foot in depth.
- Any damage to the pond embankments or slopes shall be repaired.

BMP C250: Construction Stormwater Chemical Treatment

Purpose

This BMP applies when using stormwater chemicals in batch treatment or flow-through treatment.

Turbidity is difficult to control once fine particles are suspended in stormwater runoff from a construction site. Sedimentation ponds are effective at removing larger particulate matter by gravity settling, but are ineffective at removing smaller particulates such as clay and fine silt. Traditional Construction SWPPP BMPs may not be adequate to ensure compliance with the water quality standards for turbidity in receiving water.

Conditions of Use

Formal written approval from Ecology and the city is required for the use of chemical treatment regardless of site size. The intention to use chemical treatment shall be indicated on the Notice of Intent for coverage under the NPDES General Construction Permit. Chemical treatment systems should be designed as part of the Construction SWPPP, not after the fact. Chemical treatment may be used to correct problem sites in limited circumstances with formal written approval from Ecology and the city.

Design and Installation Specifications

See Appendix II-B for background information on chemical treatment.

Criteria for Chemical Treatment Product Use: Chemically treated stormwater discharged from construction sites must be nontoxic to aquatic organisms. The Chemical Technology Assessment Protocol – Ecology (CTAPE) must be used to evaluate chemicals proposed for stormwater treatment. Only chemicals approved by Ecology under the CTAPE may be used for stormwater treatment. The approved chemicals, their allowable application techniques (batch treatment or flow-through treatment), allowable application rates, and conditions of use can be found at the Ecology Emerging Technologies web site:

<http://www.ecy.wa.gov/programs/wq/stormwater/newtech/index.html>.

Treatment System Design Considerations: The design and operation of a chemical treatment system should take into consideration the factors that determine optimum, cost-effective performance. It is important to recognize the following:

- Only Ecology approved chemicals may be used and must follow approved dose rate.
- The pH of the stormwater must be in the proper range for the polymers to be effective, which is typically 6.5 to 8.5.
- The coagulant must be mixed rapidly into the water to ensure proper dispersion.

- A flocculation step is important to increase the rate of settling, to produce the lowest turbidity, and to keep the dosage rate as low as possible.
- Too little energy input into the water during the flocculation phase results in flocs that are too small and/or insufficiently dense. Too much energy can rapidly destroy floc as it is formed.
- Care must be taken in the design of the withdrawal system to minimize outflow velocities and to prevent floc discharge. Discharge from a batch treatment system should be directed through a physical filter such as a vegetated swale that would catch any unintended floc discharge. Currently, flow-through systems always discharge through the chemically enhanced sand filtration system.
- System discharge rates must take into account downstream conveyance integrity.

Polymer Batch Treatment Process Description

A batch chemical treatment system consists of the stormwater collection system (either temporary diversion or the permanent site drainage system), storage pond, pumps, chemical feed system, treatment cells, and interconnecting piping.

The batch treatment system shall use a minimum of two lined treatment cells in addition to an untreated stormwater storage pond. Multiple treatment cells allow for clarification of treated water while other cells are being filled or emptied. Treatment cells may be ponds or tanks. Ponds with constructed earthen embankments greater than 6 feet high or that impound more than 10 acre-feet require special engineering analyses. The Ecology Dam Safety Section has specific design criteria for dams in Washington State (see www.ecy.wa.gov/programs/wr/dams/GuidanceDocs.html).

Stormwater is collected at interception point(s) on the site and is diverted by gravity or by pumping to an untreated stormwater storage pond or other untreated stormwater holding area. The stormwater is stored until treatment occurs. It is important that the holding pond be large enough to provide adequate storage.

The first step in the treatment sequence is to check the pH of the stormwater in the untreated stormwater storage pond. The pH is adjusted by the application of carbon dioxide or a base until the stormwater in the storage pond is within the desired pH range, 6.5 to 8.5. When used, carbon dioxide is added immediately downstream of the transfer pump. Typically, sodium bicarbonate (baking soda) is used as a base, although other bases may be used. When needed, base is added directly to the untreated stormwater storage pond. The stormwater is recirculated with the treatment pump to provide mixing in the storage pond. Initial pH adjustments should be based on daily bench tests. Further pH adjustments can be made at any point in the process.

Once the stormwater is within the desired pH range (dependent on polymer being used), the stormwater is pumped from the untreated stormwater storage pond to a treatment cell

as polymer is added. The polymer is added upstream of the pump to facilitate rapid mixing.

After polymer addition, the water is kept in a lined treatment cell for clarification of the sediment-floc. In a batch mode process, clarification typically takes from 30 minutes to several hours. Prior to discharge samples are withdrawn for analysis of pH, flocculent chemical concentration, and turbidity. If both are acceptable, the treated water is discharged.

Several configurations have been developed to withdraw treated water from the treatment cell. The original configuration is a device that withdraws the treated water from just beneath the water surface using a float with adjustable struts that prevent the float from settling on the cell bottom. This reduces the possibility of picking up sediment-floc from the bottom of the pond. The struts are usually set at a minimum clearance of about 12 inches; that is, the float will come within 12 inches of the bottom of the cell. Other systems have used vertical guides or cables that constrain the float, allowing it to drift up and down with the water level. More recent designs have an H-shaped array of pipes, set on the horizontal.

This scheme provides for withdrawal from four points rather than one. This configuration reduces the likelihood of sucking settled solids from the bottom. It also reduces the tendency for a vortex to form. Inlet diffusers, a long floating or fixed pipe with many small holes in it, are also an option.

Safety is a primary concern. Design should consider the hazards associated with operations, such as sampling. Facilities should be designed to reduce slip hazards and drowning. Tanks and ponds should have life rings, ladders, or steps extending from the bottom to the top.

Polymer Flow-Through Treatment Process Description

At a minimum, a flow-through chemical treatment system consists of the stormwater collection system (either temporary diversion or the permanent site drainage system), an untreated stormwater storage pond, and the chemically enhanced sand filtration system.

Stormwater is collected at interception point(s) on the site and is diverted by gravity or by pumping to an untreated stormwater storage pond or other untreated stormwater holding area. The stormwater is stored until treatment occurs. It is important that the holding pond be large enough to provide adequate storage.

Stormwater is then pumped from the untreated stormwater storage pond to the chemically enhanced sand filtration system where polymer is added. Adjustments to pH may be necessary before chemical addition. The sand filtration system continually monitors the stormwater for turbidity and pH. If the discharge water is ever out of an acceptable range for turbidity or pH, the water is recycled to the untreated stormwater pond where it can be retreated.

For batch treatment and flow-through treatment, the following equipment should be kept in a lockable shed:

- The chemical injector
- Secondary non-corrosive containment for acid, caustic, buffering compound, and treatment chemical
- Emergency shower and eyewash
- Monitoring equipment.

System Sizing

Certain sites are required to implement flow control for the developed sites. These sites must also control stormwater release rates during construction. Generally, these are sites that discharge stormwater directly, or indirectly, through a conveyance system, into a receiving water. System sizing is dependent on flow control requirements.

Sizing Criteria for Batch Treatment Systems for Flow Control Exempt Water Bodies

The total volume of the untreated stormwater storage pond and treatment ponds or tanks must be large enough to treat the volume of stormwater that is produced during multiple day storm events. It is recommended that at a minimum the untreated stormwater storage pond be sized to hold 1.5 times the runoff volume of the 10-year, 24-hour storm event. Bypass should be provided around the chemical treatment system to accommodate extreme storm events. Runoff volume shall be calculated using the methods presented in Volume III, Chapter 2. Worst-case land cover conditions (i.e., producing the most runoff) should be used for analyses (in most cases, this would be the land cover conditions just prior to final landscaping).

Primary settling should be encouraged in the untreated stormwater storage pond. A forebay with access for maintenance may be beneficial.

There are two opposing considerations in sizing the treatment cells. A larger cell can treat a larger volume of water each time a batch is processed. However, the larger the cell, the longer the time required to empty it. A larger cell may also be less effective at flocculation and therefore require a longer settling time. The simplest approach to sizing the treatment cell is to multiply the allowable discharge flow rate times the desired drawdown time. A 4-hour drawdown time allows one batch per cell per 8-hour work period, given 1 hour of flocculation followed by 2 hours of settling.

If the discharge is directly to a lake, flow control exempt receiving water listed in Volume I, or to an infiltration system, there is no discharge flow limit.

Ponds sized for flow control water bodies must at a minimum meet the sizing criteria for flow control exempt waters.

Sizing Criteria for Flow-Through Treatment Systems for Flow Control Exempt Water Bodies

When sizing storage ponds or tanks for flow-through systems for flow control exempt water bodies, the treatment system capacity should be a factor. The untreated stormwater storage pond or tank should be sized to hold 1.5 times the runoff volume of the 10-year, 24-hour storm event minus the treatment system flow rate for an 8-hour period. For a chitosan-enhanced sand filtration system, the treatment system flow rate should be sized using a hydraulic loading rate between 6 to 8 gpm/ft². Other hydraulic loading rates may be more appropriate for other systems. Bypass should be provided around the chemical treatment system to accommodate extreme storms. Bypass should be provided around the chemical treatment system to accommodate extreme storms. Runoff volume shall be calculated using the methods presented in Volume III, Chapter 2. Worst-case land cover conditions (i.e., producing the most runoff) should be used for analyses (in most cases, this would be the land cover conditions just prior to final landscaping).

Sizing Criteria for Flow Control Water Bodies

Sites that must implement flow control for the developed site condition must also control stormwater release rates during construction. Construction site stormwater discharges shall not exceed the discharge durations of the predeveloped condition for the range of predeveloped discharge rates from 50 percent of the 2-year recurrence interval flow through the 10-year flow as predicted by an approved continuous runoff model. The predeveloped condition to be matched shall be the land cover condition immediately prior to the development project. This restriction on release rates can affect the size of the storage pond and treatment cells.

The following is how WWHM can be used to determine the release rates from the chemical treatment systems:

- Determine the predeveloped flow durations to be matched by entering the existing land use area under the “Predeveloped” scenario in WWHM. The default flow range is from 50 percent of the 2-year flow through the 10-year flow.
- Enter the post developed land use area in the “Developed Unmitigated” scenario in WWHM.
- Copy the land use information from the “Developed Unmitigated” to “Developed Mitigated” scenario.
- While in the “Developed Mitigated” scenario, add a pond element under the basin element containing the postdeveloped land use areas. This pond element represents information on the available untreated stormwater storage and discharge from the chemical treatment system. In cases where the discharge from the chemical treatment system is controlled by a pump, a stage/storage/discharge (SSD) table representing the pond must be generated outside WWHM and imported into WWHM. WWHM can route the runoff from the postdeveloped condition through this SSD table (the pond) and determine compliance with the

flow duration standard. This would be an iterative design procedure where if the initial SSD table proved to be inadequate, the designer would have to modify the SSD table outside WWHM and re-import in WWHM and route the runoff through it again. The iteration will continue until a pond that complies with the flow duration standard is correctly sized.

Notes on SSD table characteristics:

- The pump discharge rate would likely be initially set at just below 50 percent of the 2-year flow from the predeveloped condition. As runoff coming into the untreated stormwater storage pond increases and the available untreated stormwater storage volume gets used up, it would be necessary to increase the pump discharge rate above 50 percent of the 2-year. The increase(s) above 50 percent of the 2-year must be such that they provide some relief to the untreated stormwater storage needs but at the same time will not cause violations of the flow duration standard at the higher flows. The final design SSD table will identify the appropriate pumping rates and the corresponding stage and storages.
- When building such a flow control system, the design must ensure that any automatic adjustments to the pumping rates will be as a result of changes to the available storage in accordance with the final design SSD table.

It should be noted that the above procedures would be used to meet the flow control requirements. The chemical treatment system must be able to meet the runoff treatment requirements. It is likely that the discharge flow rate of 50 percent of the 2-year or more may exceed the treatment capacity of the system. If that is the case, the untreated stormwater discharge rate(s) (i.e., influent to the treatment system) must be reduced to allow proper treatment. Any reduction in the flows would likely result in the need for a larger untreated stormwater storage volume.

- If the discharge is to a municipal stormwater drainage system, the allowable discharge rate may be limited by the capacity of the public system. It may be necessary to clean the municipal stormwater drainage system prior to the start of the discharge to prevent scouring solids from the drainage system. If the municipal stormwater drainage system discharges to a water body not on the flow control exempt list, the project site is subject to flow control requirements. Obtain permission from the owner of the collection system before discharging to it.
- If system design does not allow you to discharge at the slower rates as described above and if the site has a retention or detention pond that will serve the planned development, the discharge from the treatment system may be directed to the permanent retention/detention pond to comply with the flow control requirement. In this case, the untreated stormwater storage pond and treatment system will be sized according to the sizing criteria for flow-through treatment systems for flow control exempt water bodies described earlier except all discharge (water passing through the treatment system and stormwater bypassing the treatment system) will be directed into the permanent retention/detention pond. If site constraints make

locating the untreated stormwater storage pond difficult, the permanent retention/detention pond may be divided to serve as the untreated stormwater storage pond and the post-treatment flow control pond. A berm or barrier must be used in this case so the untreated water does not mix with the treated water. Both untreated stormwater storage requirements, and adequate post-treatment flow control must be achieved. The post-treatment flow control pond's revised dimensions must be entered into the WWHM and the WWHM must be run to confirm compliance with the flow control requirement.

Maintenance Standards

Monitoring: At a minimum, the following monitoring shall be conducted. Test results shall be recorded in a daily log kept on site. Additional testing may be required by the NPDES Permit based on site conditions:

Operational Monitoring

- Total volume treated and discharged
- Flow must be continuously monitored and recorded at not greater than 15-minute intervals
- Type and amount of chemical used for pH adjustment
- Amount of polymer used for treatment
- Settling time.

Compliance Monitoring

- Influent and effluent pH, flocculent chemical concentration, and turbidity must be continuously monitored and recorded at not greater than 15-minute intervals.
- pH and turbidity of the receiving water.

Biomonitoring

- Treated stormwater must be non-toxic to aquatic organisms. Treated stormwater must be tested for aquatic toxicity or residual chemical content. Frequency of biomonitoring will be determined by Ecology.
- Residual chemical tests must be approved by Ecology prior to their use.
- If testing treated stormwater for aquatic toxicity, you must test for acute (lethal) toxicity. Bioassays shall be conducted by a laboratory accredited by Ecology, unless otherwise approved by Ecology. Acute toxicity tests shall be conducted per the CTAPE protocol.

Discharge Compliance

- Prior to discharge, treated stormwater must be sampled and tested for compliance with pH, flocculent chemical concentration, and turbidity limits. These limits may be established by the Construction Stormwater General Permit or a site-specific discharge permit. Sampling and testing for other pollutants may also be necessary at some sites. pH must be within the range of 6.5 to 8.5 standard units and not cause a change in the pH of the receiving water of more than 0.2 standard units.
- Treated stormwater samples and measurements shall be taken from the discharge pipe or another location representative of the nature of the treated stormwater discharge. Samples used for determining compliance with the water quality standards in the receiving water shall not be taken from the treatment pond prior to decanting. Compliance with the water quality standards is determined in the receiving water.

Operator Training

- Each contractor who intends to use chemical treatment shall be trained by an experienced contractor. Each site using chemical treatment must have an operator trained and certified by an organization approved by Ecology.

Standard BMPs

- Surface stabilization BMPs should be implemented on site to prevent significant erosion. All sites shall use a truck wheel wash to prevent tracking sediment off site.

Sediment Removal and Disposal

- Sediment shall be removed from the storage or treatment cells as necessary. Typically, sediment removal is required at least once during a wet season and at the decommissioning of the cells. Sediment remaining in the cells between batches may enhance the settling process and reduce the required chemical dosage.
- Sediment that is known to be non-toxic may be incorporated into the site away from drainages.

BMP C251: Construction Stormwater Filtration

Purpose

Filtration removes sediment from runoff originating from disturbed areas of the site.

Background Information

Filtration with sand media has been used for over a century to treat water and wastewater. The use of sand filtration for treatment of stormwater has developed recently, generally to treat runoff from streets, parking lots, and residential areas. The application of filtration to construction stormwater treatment is currently under development.

Conditions of Use

Traditional BMPs used to control soil erosion and sediment loss from sites under development may not be adequate to ensure compliance with the water quality standard for turbidity in the receiving water. Filtration may be used in conjunction with gravity settling to remove sediment as small as fine silt (0.5 μm). The reduction in turbidity will be dependent on the particle size distribution of the sediment in the stormwater. In some circumstances, sedimentation and filtration may achieve compliance with the water quality standard for turbidity.

The use of construction stormwater filtration does not require written preapproval from Ecology or Tumwater as long as treatment chemicals are not used—approval during the normal SWPPP approval process is adequate. Filtration in conjunction with polymer treatment requires testing under CTAPE before it can be initiated. Written preapproval from the City of Tumwater and the appropriate regional Ecology office must be obtained at each site where polymers are proposed prior to use. For more guidance on stormwater chemical treatment see BMP C250.

Design and Installation Specifications

Two types of filtration systems may be applied to construction stormwater treatment: rapid and slow. Rapid sand filters are the typical system used for water and wastewater treatment. They can achieve relatively high hydraulic flow rates, on the order of 2 to 20 gpm/ft^2 , because they have automatic backwash systems to remove accumulated solids. In contrast, slow sand filters have very low hydraulic rates, on the order of 0.02 gpm/ft^2 , because they do not have backwash systems. To date, slow sand filtration has generally been used to treat stormwater. Slow sand filtration is mechanically simple in comparison to rapid sand filtration but requires a much larger filter area.

- **Filtration Equipment.** Sand media filters are available with automatic backwashing features that can filter to 50 μm particle size. Screen or bag filters can filter down to 5 μm . Fiber wound filters can remove particles down to 0.5 μm . Filters should be sequenced from the largest to the smallest pore opening. Sediment removal efficiency will be related to particle size distribution in the stormwater.

- **Treatment Process Description.** Stormwater is collected at interception point(s) on the site and is diverted to an untreated stormwater sediment pond or tank for removal of large sediment and storage of the stormwater before it is treated by the filtration system. The untreated stormwater is pumped from the trap, pond, or tank through the filtration system in a rapid sand filtration system. Slow sand filtration systems are designed as flow through systems using gravity.

Maintenance Standards

Rapid sand filters typically have automatic backwash systems that are triggered by a preset pressure drop across the filter. If the backwash water volume is not large or substantially more turbid than the untreated stormwater stored in the holding pond or tank, backwash return to the untreated stormwater pond or tank may be appropriate. However, other means of treatment and disposal may be necessary.

- Screen, bag, and fiber filters must be cleaned and/or replaced when they become clogged.
- Sediment shall be removed from the storage and/or treatment ponds as necessary. Typically, sediment removal is required once or twice during a wet season and at the decommissioning of the ponds.

Sizing Criteria for Flow-Through Treatment Systems for Flow Control Exempt Water Bodies

When sizing storage ponds or tanks for flow-through systems for flow control exempt water bodies the treatment system capacity should be a factor. The untreated stormwater storage pond or tank should be sized to hold 1.5 times the runoff volume of the 10-year, 24-hour storm event minus the treatment system flow rate for an 8-hour period. For a chitosan-enhanced sand filtration system, the treatment system flow rate should be sized using a hydraulic loading rate between 6 to 8 gpm/ft². Other hydraulic loading rates may be more appropriate for other systems. Bypass should be provided around the chemical treatment system to accommodate extreme storms. Runoff volume shall be calculated using the methods presented in Volume III, Chapter 2. Worst-case conditions (i.e., producing the most runoff) should be used for analyses (most likely conditions present prior to final landscaping).

Sizing Criteria for Flow Control Water Bodies

Sites that must implement flow control for the developed site condition must also control stormwater release rates during construction. Construction site stormwater discharges shall not exceed the discharge durations of the predeveloped condition for the range of predeveloped discharge rates from 50 percent of the 2-year recurrence interval flow through the 10-year flow as predicted by an approved continuous runoff model. The predeveloped condition to be matched shall be the land cover condition immediately prior to the development project. This restriction on release rates can affect the size of the storage pond, the filtration system, and the flow rate through the filter system.

The following is how WWHM can be used to determine the release rates from the filtration systems:

- Determine the predeveloped flow durations to be matched by entering the land use area under the “Predeveloped” scenario in WWHM. The default flow range is from 50 percent of the 2-year recurrence interval flow through the 10-year flow.
- Enter the post developed land use area in the “Developed Unmitigated” scenario in WWHM.
- Copy the land use information from the “Developed Unmitigated” to “Developed Mitigated” scenario.

There are two possible ways to model stormwater filtration systems:

1. The stormwater filtration system uses an untreated stormwater storage pond/tank and the discharge from this pond/tank is pumped to one or more filters. In-line filtration chemicals would be added to the flow right after the pond/tank and before the filter(s). Because the discharge is pumped, WWHM cannot generate a stage/storage/discharge (SSD) table for this system. This system is modeled the same way as described in BMP C250 and is as follows:
 - While in the “Developed Mitigated” scenario, add a pond element under the basin element containing the postdeveloped land use areas. This pond element represents information on the available untreated stormwater storage and discharge from the filtration system. In cases where the discharge from the filtration system is controlled by a pump, a stage/storage/discharge (SSD) table representing the pond must be generated outside WWHM and imported into WWHM. WWHM can route the runoff from the postdeveloped condition through this SSD table (the pond) and determine compliance with the flow duration standard. This would be an iterative design procedure where if the initial SSD table proved to be out of compliance, the designer would have to modify the SSD table outside WWHM and re-import in WWHM and route the runoff through it again. The iteration will continue until a pond that enables compliance with the flow duration standard is designed.
 - Notes on SSD table characteristics:

The pump discharge rate would likely be initially set at just below one-half of the 2-year recurrence interval flow from the predeveloped condition. As runoff coming into the untreated stormwater storage pond increases and the available untreated stormwater storage volume gets used up, it would be necessary to increase the pump discharge rate above 50 percent of the 2-year recurrence interval flow. The increase(s) above 50 percent of the 2-year must be such that they provide some relief to the untreated stormwater storage needs but at the same time they will not cause violations of the flow duration

standard at the higher flows. The final design SSD table will identify the appropriate pumping rates and the corresponding stage and storages.

- When building such a flow control system, the design must ensure that any automatic adjustments to the pumping rates will be as a result of changes to the available storage in accordance with the final design SSD table.
2. The stormwater filtration system uses a storage pond/tank and the discharge from this pond/tank gravity flows to the filter. This is usually a slow sand filter system and it is possible to model it in WWHM as a Filter element or as a combination of Pond and Filter element placed in series. The stage/storage/discharge table(s) may then be generated within WWHM as follows:
- While in the “Developed Mitigated” scenario, add a Filter element under the basin element containing the postdeveloped land use areas. The length and width of this filter element would have to be the same as the bottom length and width of the upstream untreated stormwater storage pond/tank.
 - In cases where the length and width of the filter is not the same as those for the bottom of the upstream untreated stormwater storage tank/pond, the treatment system may be modeled as a Pond element followed by a Filter element. By having these two elements, WWHM would then generate a SSD table for the storage pond, which then gravity flows to the Filter element. The Filter element downstream of the untreated stormwater storage pond would have a storage component through the media, and an overflow component for when the filtration capacity is exceeded.
- WWHM can route the runoff from the postdeveloped condition through the treatment systems in 4b and determine compliance with the flow duration standard. This would be an iterative design procedure where if the initial sizing estimates for the treatment system proved to be inadequate, the designer would have to modify the system and route the runoff through it again. The iteration would continue until compliance with the flow duration standard is achieved.
 - It should be noted that the above procedures would be used to meet the flow control requirements. The filtration system must be able to meet the runoff treatment requirements. It is likely that the discharge flow rate of 50 percent of the 2-year recurrence interval flow or more may exceed the treatment capacity of the system. If that is the case, the untreated stormwater discharge rate(s) (i.e., influent to the treatment system) must be reduced to allow proper treatment. Any reduction in the flows would likely result in the need for a larger untreated stormwater storage volume.
 - If system design does not allow you to discharge at the slower rates as described above and if the site has a retention or detention pond that will serve the planned development, the discharge from the treatment system may be directed to the permanent retention/detention pond to comply with the flow control requirements.

In this case, the untreated stormwater storage pond and treatment system will be sized according to the sizing criteria for flow-through treatment systems for flow control exempt waterbodies described earlier except all discharges (water passing through the treatment system and stormwater bypassing the treatment system) will be directed into the permanent retention/detention pond. If site constraints make locating the untreated stormwater storage pond difficult, the permanent retention/detention pond may be divided to serve as the untreated stormwater discharge pond and the post-treatment flow control pond. A berm or barrier must be used in this case so the untreated water does not mix with the treated water. Both untreated stormwater storage requirements, and adequate post-treatment flow control must be achieved. The post-treatment flow control pond's revised dimensions must be entered into the WWHM and the WWHM must be run to confirm compliance with the flow control requirement.

BMP C252: High pH Neutralization Using CO₂

Purpose

When pH levels in stormwater rise above 8.5 it is necessary to lower the pH levels to the acceptable range of 6.5 to 8.5, this process is called pH neutralization. pH neutralization (CO₂ sparging) involves the use of solid or compressed carbon dioxide gas in water requiring neutralization. Neutralized stormwater may be discharged to surface waters under the NPDES Construction Stormwater General Permit.

Neutralized process water (i.e., water created during the course of concrete work) such as concrete truck washout, hydro-demolition, or saw-cutting slurry must be managed to prevent discharge to surface waters. Any stormwater contaminated during concrete work is considered process wastewater and must be collected and disposed of off site; it may not be discharged to surface waters.

Reason for pH Neutralization

- A pH level range of 6.5 to 8.5 is typical for most natural watercourses, and this neutral pH is required for the survival of aquatic organisms. Should the pH rise or drop out of this range, fish and other aquatic organisms may become stressed and may die.
- Calcium hardness can contribute to high pH values and cause toxicity that is associated with high pH conditions. A high level of calcium hardness in waters of the state is not allowed.
- The water quality standard for pH in Washington State is in the range of 6.5 to 8.5. Groundwater standard for calcium and other dissolved solids in Washington State is less than 500 mg/l.

Causes of High pH

High pH at construction sites is most commonly caused by the contact of stormwater with newly placed cement containing products including poured or recycled concrete, cement, mortars, and other portland cement or lime-containing construction materials. (See BMP C151: Concrete Handling, for more information on concrete handling procedures.) The principal caustic agent in cement is calcium hydroxide (free lime).

Advantages of CO₂ Sparging

- Rapidly neutralizes high pH water
- Cost-effective and safer to handle than acid compounds
- CO₂ is self-buffering. It is difficult to overdose and create harmfully low pH levels.
- Material is readily available.

The Chemical Process

- When CO₂ is added to water (H₂O), carbonic acid (H₂CO₃) is formed, which can further dissociate into a proton (H⁺) and a bicarbonate anion (HCO₃⁻) as shown below:

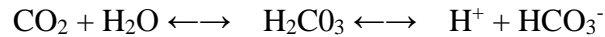

- The free proton is a weak acid that can lower the pH. Water temperature affects the reaction, as well. The colder the water temperature is, the slower the reaction occurs; and the warmer the water temperature is, the quicker the reaction occurs. Most construction applications in Washington State have water temperatures in the 50°F or higher range so the reaction is almost simultaneous.

Treatment Procedures

- High pH water may be treated using continuous treatment, continuous discharge systems. These manufactured systems continuously monitor influent and effluent pH to ensure that pH values are within an acceptable range before being discharged. All systems must have fail safe automatic shut off switches in the event that pH is not within the acceptable discharge range. Only trained operators may operate manufactured systems. System manufacturers often provide trained operators or training on their devices.
- The following procedure may be used when not using a continuous discharge system:
 - Prior to treatment, the city must be notified.
 - Every effort should be made to isolate the potential high pH water in order to treat it separately from other stormwater on site.
 - Water should be stored in an acceptable storage facility, detention pond, or containment cell prior to treatment.
 - Transfer water to be treated to the treatment structure. Ensure that treatment structure size is sufficient to hold the amount of water that is to be treated. Do not fill tank completely; allow at least 2 feet of freeboard.
 - The operator samples the water for pH and notes the clarity of the water. As a rule of thumb, less CO₂ is necessary for clearer water. This information should be recorded.
 - In the pH adjustment structure, add CO₂ until the pH falls in the range of 6.9 to 7.1. Remember that pH water quality standards apply so adjusting pH to within 0.2 pH unit of receiving water (background pH) is recommended. It is unlikely that pH can be adjusted to within 0.2 pH unit using dry ice. Compressed carbon dioxide gas should be introduced to the water using a

carbon dioxide diffuser located near the bottom of the tank; this will allow carbon dioxide to bubble up through the water and diffuse more evenly.

- Slowly release the water to discharge making sure water does not get stirred up in the process. Release about 80 percent of the water from the structure leaving any sludge behind.
- Discharge treated water through a pond or drainage system.
- Excess sludge needs to be disposed of properly as concrete waste. If several batches of water are undergoing pH treatment, sludge can be left in treatment structure for the next batch treatment. Dispose of sludge when it fills 50 percent of tank volume.
- Sites that must implement flow control for the developed site must also control stormwater release rates during construction. All treated stormwater must go through a flow control facility before being released to surface waters that require flow control.

Safety and Materials Handling

- All equipment should be handled in accordance with OSHA rules and regulations
- Follow manufacturer guidelines for materials handling.

Operator Records

- Each operator should provide:
 - A diagram of the monitoring and treatment equipment
 - A description of the pumping rates and capacity the treatment equipment is capable of treating
- Each operator should keep a written record of the following:
 - Client name, telephone number, and email address
 - Date of treatment
 - Weather conditions
 - Project name and location
 - Volume of water treated
 - pH of untreated water

- Amount of CO₂ needed to adjust water to a pH range of 6.9 to 7.1
- pH of treated water
- Discharge location and description
- A copy of this record should be given to the client/contractor who should retain the record for 3 years.

BMP C253: pH Control for High pH Water

Description

When pH levels in stormwater rise above 8.5 it is necessary to lower the pH levels to the acceptable range of 6.5 to 8.5, this process is called pH neutralization. Stormwater with pH levels exceeding water quality standards may be treated by infiltration, dispersion in vegetation or compost, pumping to a sanitary sewer, disposal at a permitted concrete batch plant with pH neutralization capabilities, or carbon dioxide sparging. BMP C252 gives guidelines for carbon dioxide sparging.

Reason for pH Neutralization

A pH level range of 6.5 to 8.5 is typical for most natural watercourses, and this pH range is required for the survival of aquatic organisms. Should the pH rise or drop out of this range, fish and other aquatic organisms may become stressed and may die.

Causes of High pH

High pH at construction sites is most commonly caused by the contact of stormwater with newly placed cement containing products including poured or recycled concrete, cement, mortars, and other portland cement or lime-containing construction materials. (See BMP C151: Concrete Handling, for more information on concrete-handling procedures.) The principal caustic agent in cement is calcium hydroxide (free lime).

Disposal Methods

Infiltration

- Infiltration is only allowed if soil type allows all water to infiltrate (no surface runoff) without causing or contributing to a violation of surface or groundwater quality standards.
- Infiltration techniques should be consistent with Volume V.

Dispersion

- Use sheet flow or concentrated flow dispersion in Volume V, Chapter 7.

Sanitary Sewer Disposal

- For discharges to the sanitary sewer, permits must be obtained from the LOTT Alliance Industrial Pretreatment Program at 360-528-5708.

Concrete Batch Plant Disposal

- Only permitted facilities may accept high pH water.
- Facility should be contacted before delivery to the plant to ensure they can accept the high pH water.

Stormwater Discharge

- Any pH treatment options that generate treated water that must be discharged off site are subject to flow control requirements. Sites that must implement flow control for the developed site must also control stormwater release rates during construction. All treated stormwater must go through a flow control facility before being released to surface waters that require flow control.

3.3 Protection of LID Facilities During Construction

3.3.1 Introduction

To ensure that LID stormwater facilities and BMPs will be fully functional after construction, it is important to protect these BMPs during construction activities. Protecting native soil and vegetation, minimizing soil compaction, and retaining the hydrologic function of LID BMPs during the site preparation and construction phases are some of the most important practices during the development process.

The purpose of this section is to provide designers, builders, and inspectors with guidance and tools for meeting Minimum Requirement #2, Element #13 (See Volume I) – Protect Low Impact Development BMPs. This section does not provide guidance on construction or design of LID BMPs (see Volume III and V), or cover all Construction SWPPP practices (see Sections 3.1 and 3.2), but rather focuses on how to most efficiently reduce impacts on LID BMPs specifically during construction. **The practices specified in this section must be applied to protect LID BMPs, unless the given practice does not apply to the project site conditions or activities.**

3.3.2 General Erosion and Sediment Control BMPs Applicable to LID

Overall Construction SWPPP requirements are specified in Minimum Requirement #2 (Volume I) and Volume II. In general, Construction SWPPP BMPs limit the impact of site disturbance, erosion, and sediment deposition during construction. Some Construction SWPPP BMPs (presented in more detail in Sections 3.1 and 3.2) focus on providing a physical barrier or deterrent to help minimize construction-related site disturbance and/or erosion, while other Construction SWPPP BMPs help protect the site from concentrated (i.e., erosive) flows. General Construction SWPPP BMPs and their application for protection of LID BMPs are summarized in Table 3.15. These BMPs must be considered for projects subject to Minimum Requirement #2 (Volume I) that are proposing to construct LID BMPs.

Construction SWPPP BMP	Application	Section Reference
BMP C103: High Visibility Fence	Use fencing to limit clearing; prevent disturbance of sensitive areas, their buffers, and other areas; limit construction traffic; and protect areas where marking with flagging may not provide adequate protection.	3.1
BMP C200: Interceptor Dike and Swale	Use an interceptor dike and/or swale to intercept the runoff from unprotected areas and direct it to areas where erosion can be controlled.	3.2
BMP C201: Grass-Lined Channels	Use grass-lined channels where concentrated runoff may cause erosion and flooding of the site.	3.2
BMP C207: Check Dams	Use check dams in swales or ditches to reduce the velocity and dissipate concentrated flow.	3.2
BMP C208: Triangular Silt Dike (TSD) (Geotextile-Encased Check Dam)	Use triangular silt dikes as check dams for perimeter protection, temporary soil stockpile protection, drop inlet protection, or as a temporary interceptor dike.	3.2
BMP C233: Silt Fence	Use silt fences to decrease flow velocities and reduce transport of sediment from overland flow.	3.2
BMP C234: Vegetated Strip	Use vegetated strips to decrease flow velocities and reduce transport of sediment from overland flow.	3.2

3.3.3 Additional Construction Techniques for LID BMPs

In addition to the general Construction SWPPP BMPs presented in Section 3.3.2, this section outlines construction-phase techniques to protect LID BMPs. LID BMP protection is still a somewhat new and evolving practice, therefore the specific LID BMP protection measures outlined below are not explicitly called out in Sections 3.1 and 3.2. Rather, the techniques presented in this section supplement the Construction SWPPP BMPs presented above and in Sections 3.1 and 3.2. *(Note: these techniques can be applied to any site, not just those incorporating LID, but these techniques are particularly important for LID BMP protection.)*

Construction Site Planning and Sequencing

Construction site planning and sequencing is a procedural BMP that is critical to successful installation and long-term operation of LID BMPs. Proper site planning and construction sequencing will minimize the impact of construction on permanent stormwater facilities by reducing the potential for soil erosion and compaction. Site planning and sequencing techniques to be used as practicable for protection of LID BMPs are listed in Table 3.16.

Table 3.16. Construction Site Planning and Sequencing Techniques to Protect LID BMPs.

Construction Site Planning and Sequencing Requirements	Construction Site Planning and Sequencing Techniques
Limit clearing and grading activities	<ul style="list-style-type: none"> • Keep grading to a minimum by incorporating natural topographic depressions into the development. • Shape final lot grades and topographic features early (i.e., at the site development stage) where feasible. • Limit the amount of cut and fill in areas with permeable soils. • Limit clearing to road, utility, building pad, lawn areas, and the minimum amount of extra land necessary to maneuver machinery (e.g., a 10-foot perimeter around a building).
Limit construction activity in areas designated for LID	<ul style="list-style-type: none"> • Clearly document—and plan to meet and walk through the site with equipment operators prior to construction—to clarify construction boundaries, limits of disturbance, and construction activities in the vicinity of LID BMPs. • General/primary contractor must inform other sub-contractors of applicable LID BMP protection requirements. This is particularly important when working around permeable pavement.
Limit clearing and grading during heavy rainfall seasons	<ul style="list-style-type: none"> • Time construction activities to start during the summer (lowest precipitation) and end in the fall (when conditions are favorable for the establishment of vegetation), if feasible.
Minimize the amount and time that graded areas are left exposed	<ul style="list-style-type: none"> • Complete construction and erosion control activities in one section of the site before beginning activity in another section.
Utilize permeable and nutrient rich soils	<ul style="list-style-type: none"> • Preserve any portion of the site with permeable soils to promote infiltration of stormwater runoff. • Leave areas of rich topsoil in place, or if excavated, utilize elsewhere on the site to amend areas with sparse or nutrient deficient topsoil.
Reduce impact of construction access roads	<ul style="list-style-type: none"> • Reduce the number and size (width/length) of construction access roads. • Locate construction access roads in areas where future roads and utility corridors will be placed (unless utilizing permeable pavement).
Promote sheet flow and minimize concentrated runoff	<ul style="list-style-type: none"> • Avoid grading that results in steep, continuous slopes, especially in areas contributing runoff to LID BMPs.
LID BMP activation	<ul style="list-style-type: none"> • LID BMPs shall not begin operation until all erosion-causing project improvements (including use of access roads that may contribute sediment) are completed and all exposed ground surfaces are stabilized by revegetation or landscaping in upland areas potentially contributing runoff to the BMP.

Activities During Construction

Many common construction-phase activities pose a risk to LID BMPs. The techniques in Table 3.17 will help minimize these impacts by protecting LID BMPs.

Table 3.17. Activities During Construction to Protect LID BMPs.	
Erosion Control Requirements	Erosion Control Techniques
Protect native topsoil during the construction phase, and reuse on site	<ul style="list-style-type: none"> • Where practicable, protect areas of rich topsoil. If excavation is necessary, stockpile native soils that can be used on the site after construction. • Stockpile materials in areas designated for clearing and grading (such as parking areas and future impervious roadways) and away from infiltration and other stormwater facilities. • Cover small stockpiles with weed barrier material that sheds moisture yet allows air transmission. Large stockpiles may need to be seeded and/or mulched. • Do not relocate topsoil or other material to areas where they can cover critical root zones, suffocate vegetation, or erode into adjacent streams.
Use effective revegetation methods	<ul style="list-style-type: none"> • Use native plant species adapted to the local environment. • Plant during late fall, winter, or early spring months when vegetation is likely to establish quickly and survive. • Utilize proper seedbed preparation. • Fertilize and mulch to protect germinating plants. Apply 1 inch of compost topped with 2 inches of mulch. • Protect areas designated for revegetation from soil compaction by restricting heavy equipment. • Provide proper soil amendments where necessary (refer to Volume V, Chapter 6). • During storage, plants should be protected by solar screens when possible to prevent overexposure and excessive drying.
Perform preconstruction, routine, and postconstruction inspections	<ul style="list-style-type: none"> • Conduct a preconstruction inspection to verify that adequate barriers have been placed around vegetation retention areas, infiltration facilities (as needed), and structural controls are implemented properly. • Conduct routine inspections to verify that structural controls are being maintained and effectively protecting LID BMPs throughout construction. • Conduct a final inspection to verify that revegetation areas are stabilized and that permanent LID BMPs are in place and functioning properly.

3.3.4 BMP-Specific Construction Techniques

This section outlines construction-phase BMP protection techniques specific to *categories* of LID BMPs (e.g., infiltration and dispersion) as well as *specific* LID BMPs (permeable pavement, bioretention areas/rain gardens, and vegetated roofs). The BMP protection techniques presented previously in Section 3.3.3 are applicable to the overall construction site to help protect LID BMPs. The techniques outlined in this section are based on the specific BMP functions, targeting typical construction activities that pose a risk to individual BMPs.

Infiltration and Dispersion Facility Construction Techniques

It is critical that appropriate methods are used to protect infiltration and dispersion BMPs from compaction and sediment loading during construction. For infiltration facilities in particular, the subgrade soils must be protected from clogging and over-compaction to maintain the soil permeability and ensure BMP performance. Techniques for protection of infiltration and dispersion BMPs during various stages of construction are summarized in Table 3.18.

Table 3.18. Techniques to Protect Infiltration and Dispersion Facility During Construction.	
Construction Stage	Techniques for Protecting Infiltration and Dispersion Facilities
Prior to construction	<ul style="list-style-type: none"> • The infiltration/dispersion area shall be clearly identified (e.g., using flagging or high visibility fencing) and protected prior to construction to prevent compaction of underlying soils by vehicle traffic. • Develop a soil and vegetation management plan showing areas to be protected and restoration methods for disturbed areas before land clearing starts. • The Construction SWPPP sheets must outline construction sequencing that will protect the infiltration/dispersion area during construction. • Construction SWPPP BMPs and protection techniques identified in Sections 3.3.2 and 3.3.3 shall be implemented as applicable. In particular, be sure to stabilize upslope construction areas (e.g., using silt fences, berms, mulch, or other Construction SWPPP BMPs) and minimize overland flow distances.
Excavation	<ul style="list-style-type: none"> • Excavation of infiltration/dispersion areas shall be performed by machinery operating adjacent to the BMP. No heavy equipment with narrow tracks, narrow tires, or large lugged high pressure tires shall be allowed on the infiltration/dispersion area footprint. • Where feasible, excavate infiltration/dispersion areas to final grade only after all disturbed areas in the up-gradient project drainage area have been permanently stabilized. (If infiltration areas must be excavated before final stabilization, initial excavation must leave at least 6 inches of native material above the finished grade.) • Excavation of infiltration areas shall not be allowed during wet or saturated conditions. • The use of draglines and trackhoes should be considered for constructing infiltration and dispersion areas. • The sidewalls and bottom of an infiltration facility excavation must be raked or scarified to a minimum depth of 3 inches after final excavation to restore infiltration rates. • Scarify soil along the dispersion flowpath if disturbed during construction.
Sediment control	<ul style="list-style-type: none"> • Bioretention, rain garden, and permeable pavement BMPs shall not be used as sediment control facilities, and all drainage shall be directed away from the BMP location after initial rough grading. • Direct construction site flow away from the infiltration/dispersion area using applicable Construction SWPPP BMPs (e.g., temporary diversion swales).

Permeable Pavement

There are many potential applications and site scenarios where permeable pavement can be applied. The following techniques highlight the most broadly applicable techniques to be used to protect permeable pavement BMPs during construction. Refer to the previous section for construction protection methods that are applicable to all infiltration BMPs, as well as Sections 3.3.2 and 3.3.3 for general site protection measures. In addition to those techniques, the following techniques apply specifically for protection of permeable pavement during construction:

- Use procedural BMPs to plan construction. For example, phase construction to minimize compaction, sedimentation, or structural damage to the permeable pavement.
- Use physical Construction SWPPP BMPs and/or grade the site to avoid sediment laden runoff from reaching permeable pavements.
- Place protective surfaces (e.g., waterproof tarps and steel plates) over any permeable pavement areas used for construction staging.
- Do not drive sediment-laden construction equipment on the base material or pavement. Do not allow sediment-laden runoff on permeable pavements or base materials.
- Once the pavement is finished and set, cover the pavement surface with plastic and geotextile to protect from other construction activities. Close and protect the pavement area until the site is permanently stabilized.
- Incorporate measures to protect road subgrade from over compaction and sedimentation if permeable pavement roads are used for construction access.
 - Cover the aggregate base or pavement surface with protective geotextile fabric and protect fabric with steel plates or gravel. Gravel should only be used to protect the fabric placed over aggregate base.
 - Once construction is complete and the site is permanently stabilized, remove protective geotextile, clean, and complete pavement installation.

Refer to the detailed permeable pavement BMP information in Volume V, Chapter 11 for general permeable pavement construction criteria.

Bioretention Areas and Rain Gardens

As with permeable pavements, there are many potential applications and site scenarios where bioretention and rain garden BMPs can be applied. The following techniques highlight the most broadly applicable techniques to be used to protect bioretention and rain garden BMPs during construction. Refer to the beginning of this section for construction protection methods that are applicable to all infiltration BMPs, as well as

Section 3.3.2 and 3.3.3 for general site protection measures. In addition to those techniques, the following techniques apply specifically for protection of bioretention and rain garden BMPs during construction:

- Excavation:
 - If machinery must operate in the bioretention area for excavation, use lightweight, low ground-contact pressure equipment and rip the native soil at completion to scarify soil to a minimum of 12 inches.
- Protect bioretention soil mix from compaction during construction
 - Do not place bioretention soil mix if saturated or during wet periods.
 - Check for compaction prior to planting. If compaction occurs, aerate the bioretention soil and then proceed to plant.
 - Conduct verification of performance testing after facility completion to confirm design infiltration rates have been maintained.

Refer to the detailed bioretention and rain garden BMP information in Volume V, Chapters 9 and 10, for general bioretention and rain garden construction criteria.

Vegetated Roofs

The following additional techniques apply for protection of vegetated roof facilities during construction:

- Because of their location and complexity, vegetated roofs typically require more planning and coordination effort relative to ground-level landscaping. For new construction, a critical path approach is highly recommended to establish the sequence of tasks for construction of the vegetated roof system.
- During construction, it is vitally important that the waterproof membrane be protected once installed. The waterproofing should be tested prior to placement of the growth media and other subsequent vegetated roof materials.

Refer to the detailed vegetated roof BMP information in Volume V for general construction criteria.

Appendix II-A

Recommended Standard Notes for Construction Stormwater Pollution Prevention Plans

The following standard notes are suggested for use in construction stormwater pollution prevention plans (SWPPPs). The city has other mandatory notes for construction plans that are applicable, see Volume I, Chapter 3. Plans should also identify with phone numbers and email addresses of the person or firm responsible for the preparation of and maintenance of the Construction SWPPP.

Standard Notes

Approval of this Construction SWPPP does not constitute an approval of permanent road or drainage design (e.g., size and location of roads, pipes, restrictors, channels, retention/detention/infiltration facilities, utilities, etc.).

The implementation of this Construction SWPPP and the construction, maintenance, replacement, and upgrading of these Construction SWPPP facilities is the responsibility of the applicant/contractor until all construction is completed and approved and vegetation/landscaping is established.

The boundaries of the clearing limits shown on this plan shall be clearly flagged in the field prior to construction. During the construction period, no disturbance beyond the flagged clearing limits shall be permitted. The flagging shall be maintained by the applicant/contractor for the duration of construction.

The Construction SWPPP facilities shown on this plan must be constructed in conjunction with all clearing and grading activities, and in such a manner as to ensure that sediment and sediment laden water do not enter the drainage system, roadways, or violate applicable water standards.

The Construction SWPPP facilities shown on this plan are the minimum requirements for anticipated site conditions. During the construction period, these ESC facilities shall be upgraded as needed for unexpected storm events and to ensure that sediment and sediment-laden water do not leave the site.

The Construction SWPPP facilities shall be inspected daily by the applicant/contractor and maintained as necessary to ensure their continued functioning.

The Construction SWPPP facilities on inactive sites shall be inspected and maintained a minimum of once a month or within the 48 hours following a major storm event.

At no time shall more than 1 foot of sediment be allowed to accumulate within a catch basin trap (or sump). All catch basins and conveyance lines shall be cleaned prior to

paving. The sediment cleaning operation shall not flush sediment laden water into the downstream system.

Stabilized construction entrances shall be installed at the beginning of construction and maintained for the duration of the project. Additional measures may be required to ensure that all paved areas are kept clean for the duration of the project.

Appendix II-B

Background Information on Chemical Treatment

Coagulation and flocculation have been used for over a century to treat water. It is used less frequently for the treatment of wastewater. The use of coagulation and flocculation for treating stormwater is a very recent application. Experience with the treatment of water and wastewater has resulted in a basic understanding of the process, in particular factors that affect performance. This experience can provide insights as to how to most effectively design and operate similar systems in the treatment of stormwater.

Fine particles suspended in water give it a milky appearance, measured as turbidity. Their small size, often much less than 1 μm in diameter, give them a very large surface area relative to their volume. These fine particles typically carry a negative surface charge. Largely because of these two factors, small size and negative charge, these particles tend to stay in suspension for extended periods of time. Thus, removal is not practical by gravity settling. These are called stable suspensions. Polymers, as well as inorganic chemicals such as alum, speed the process of clarification. The added chemical destabilizes the suspension and causes the smaller particles to agglomerate. The process consists of three steps: coagulation, flocculation, and settling or clarification. Each step is explained below as well as the factors that affect the efficiency of the process.

1. **Coagulation:** Coagulation is the first step. It is the process by which negative charges on the fine particles that prevent their agglomeration are disrupted. Chemical addition is one method of destabilizing the suspension, and polymers are one class of chemicals that are generally effective. Chemicals that are used for this purpose are called coagulants. Coagulation is complete when the suspension is destabilized by the neutralization of the negative charges. Coagulants perform best when they are thoroughly and evenly dispersed under relatively intense mixing. This rapid mixing involves adding the coagulant in a manner that promotes rapid dispersion, followed by a short time period for destabilization of the particle suspension. The particles are still very small and are not readily separated by clarification until flocculation occurs.
2. **Flocculation:** Flocculation is the process by which fine particles that have been destabilized bind together to form larger particles that settle rapidly. Flocculation begins naturally following coagulation, but is enhanced by gentle mixing of the destabilized suspension. Gentle mixing helps to bring particles in contact with one another such that they bind and continually grow to form “flocs.” As the size of the flocs increases they become heavier and tend to settle more rapidly.
3. **Clarification:** The final step is the settling of the particles. Particle density, size and shape are important during settling. Dense, compact flocs settle more readily than less dense, fluffy flocs. Because of this, flocculation to form dense, compact flocs is particularly important during water treatment. Water temperature is important during settling. Both the density and viscosity of water are affected by

temperature; these in turn affect settling. Cold temperatures increase viscosity and density, thus slowing down the rate at which the particles settle.

The conditions under which clarification is achieved can affect performance. Currents can affect settling. Currents can be produced by wind, by differences between the temperature of the incoming water and the water in the clarifier, and by flow conditions near the inlets and outlets. Quiescent water such as that which occurs during batch clarification provides a good environment for effective performance as many of these factors become less important in comparison to typical sedimentation basins. One source of currents that is likely important in batch systems is movement of the water leaving the clarifier unit. Given that flocs are relatively small and light the exit velocity of the water must be as low as possible. Sediment on the bottom of the basin can be resuspended and removed by fairly modest velocities.

Coagulants: Polymers are large organic molecules that are made up of subunits linked together in a chain-like structure. Attached to these chain-like structures are other groups that carry positive or negative charges, or have no charge. Polymers that carry groups with positive charges are called cationic, those with negative charges are called anionic, and those with no charge (neutral) are called nonionic.

Cationic polymers can be used as coagulants to destabilize negatively charged turbidity particles present in natural waters, wastewater and stormwater. Aluminum sulfate (alum) can also be used as this chemical becomes positively charged when dispersed in water. In practice, the only way to determine whether a polymer is effective for a specific application is to perform preliminary or on-site testing.

Polymers are available as powders, concentrated liquids, and emulsions (which appear as milky liquids). The latter are petroleum based, which are not allowed for construction stormwater treatment. Polymer effectiveness can degrade with time and also from other influences. Thus, manufacturers' recommendations for storage should be followed. Manufacturer's recommendations usually do not provide assurance of water quality protection or safety to aquatic organisms. Consideration of water quality protection is necessary in the selection and use of all polymers.

Application Considerations: Application of coagulants at the appropriate concentration or dosage rate for optimum turbidity removal is important for management of chemical cost, for effective performance, and to avoid aquatic toxicity. The optimum dose in a given application depends on several site-specific features. Turbidity of untreated water can be important with turbidities greater than 5,000 NTU. The surface charge of particles to be removed is also important. Environmental factors that can influence dosage rate are water temperature, pH, and the presence of constituents that consume or otherwise affect polymer effectiveness. Laboratory experiments indicate that mixing previously settled sediment (floc sludge) with the untreated stormwater significantly improves clarification, therefore reducing the effective dosage rate. Preparation of working solutions and thorough dispersal of polymers in water to be treated is also important to establish the appropriate dosage rate.

For a given water sample, there is generally an optimum dosage rate that yields the lowest residual turbidity after settling. When dosage rates below this optimum value (underdosing) are applied, there is an insufficient quantity of coagulant to react with, and therefore destabilize, all of the turbidity present. The result is residual turbidity (after flocculation and settling) that is higher than with the optimum dose. Overdosing, application of dosage rates greater than the optimum value, can also negatively impact performance. Again, the result is higher residual turbidity than that with the optimum dose.

Mixing in Coagulation/Flocculation: The G-value, or just “G,” is often used as a measure of the mixing intensity applied during coagulation and flocculation. The symbol G stands for “velocity gradient,” which is related in part to the degree of turbulence generated during mixing. High G-values mean high turbulence, and vice versa. High G-values provide the best conditions for coagulant addition. With high G’s, turbulence is high and coagulants are rapidly dispersed to their appropriate concentrations for effective destabilization of particle suspensions.

Low G-values provide the best conditions for flocculation. Here, the goal is to promote formation of dense, compact flocs that will settle readily. Low G’s provide low turbulence to promote particle collisions so that flocs can form. Low G’s generate sufficient turbulence such that collisions are effective in floc formation, but do not break up flocs that have already formed.

Design engineers wishing to review more detailed presentations on this subject are referred to the following textbooks.

- Fair, G., J. Geyer and D. Okun, *Water and Wastewater Engineering*, Wiley and Sons, New York, 1968.
- American Water Works Association, *Water Quality and Treatment*, McGraw-Hill, New York, 1990.
- Weber, W.J., *Physiochemical Processes for Water Quality Control*, Wiley and Sons, New York, 1972.

Adjustment of the pH and Alkalinity: The pH must be in the proper range for the polymers to be effective, which is 6.5 to 8.5 for Calgon CatFloc 2953, the most commonly used polymer. As polymers tend to lower the pH, it is important that the stormwater have sufficient buffering capacity. Buffering capacity is a function of alkalinity. Without sufficient alkalinity, the application of the polymer may lower the pH to below 6.5. A pH below 6.5 not only reduces the effectiveness of the polymer, it may create a toxic condition for aquatic organisms. Stormwater may not be discharged without readjustment of the pH to above 6.5. The target pH should be within 0.2 standard units of the receiving water pH.

Experience gained at several projects in the City of Redmond has shown that the alkalinity needs to be at least 50 mg/L to prevent a drop in pH to below 6.5 when the polymer is added.